

[54] COMBINED VEHICLE SUSPENSION AND SHOCK ABSORBER

[56] References Cited

U.S. PATENT DOCUMENTS

3,173,670 3/1965 Hornsby ..... 280/670

[76] Inventor: James C. Dickey, 45199 Rector Dr., Canton, Mich. 48188

Primary Examiner—James M. Gandy  
Attorney, Agent, or Firm—W. C. Tupman

[\*\*] Term: 14 Years

[57] CLAIM

The ornamental design for a combined vehicle suspension and shock absorber, as shown.

[21] Appl. No.: 806,928

DESCRIPTION

FIG. 1 is a side elevation view of a combined vehicle suspension and shock absorber showing my new design; FIG. 2 is a front elevation view thereof; FIG. 3 is a bottom plan view thereof; FIG. 4 is a top plan view thereof; FIG. 5 is a rear elevation view thereof; and FIG. 6 is an isometric view thereof on a reduced scale.

[22] Filed: Nov. 27, 1985

[52] U.S. Cl. .... D12/159

[58] Field of Search ..... D12/159; 280/701, 670; 267/61 R, 64.19, 64.23, 64.27

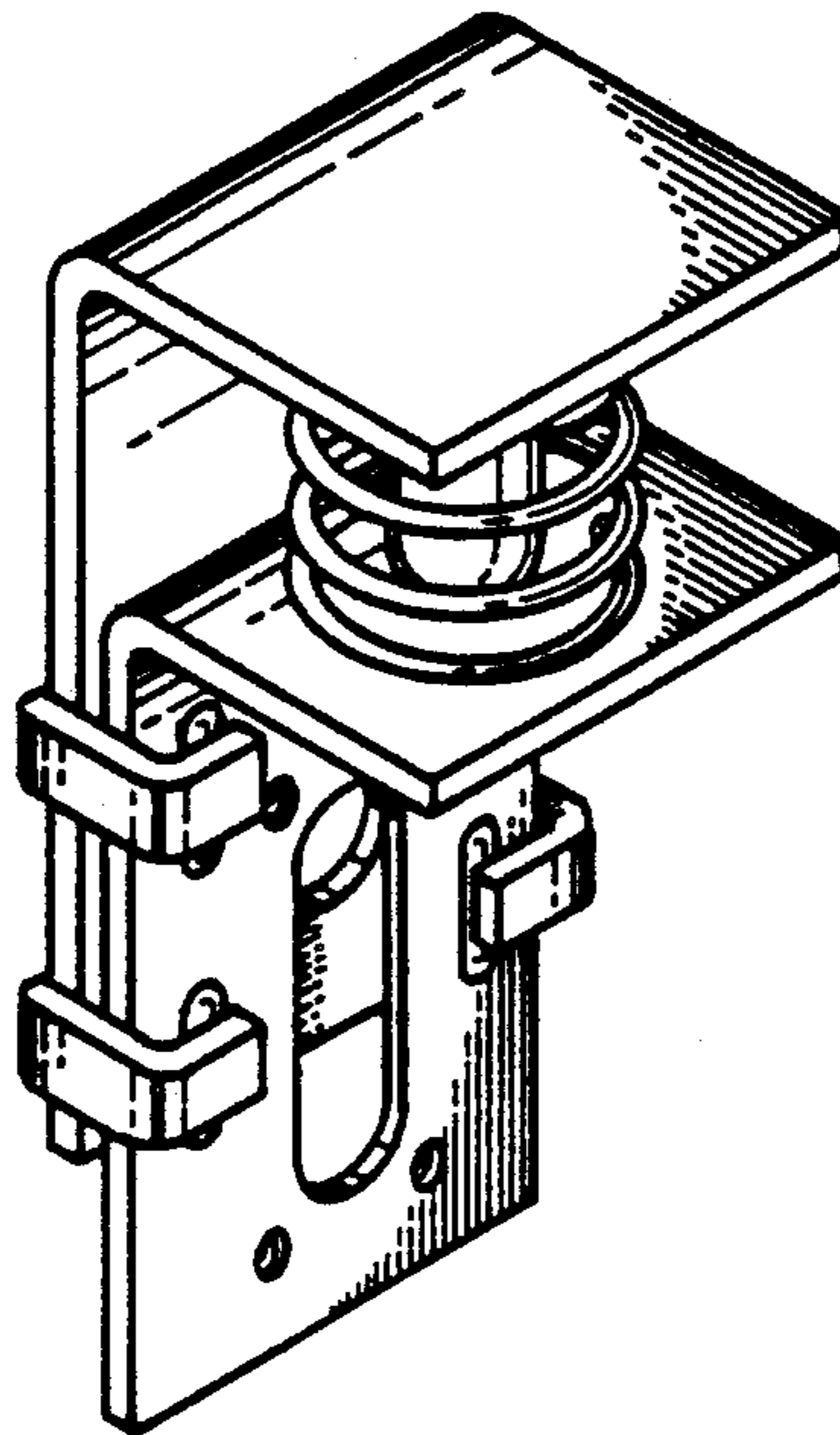

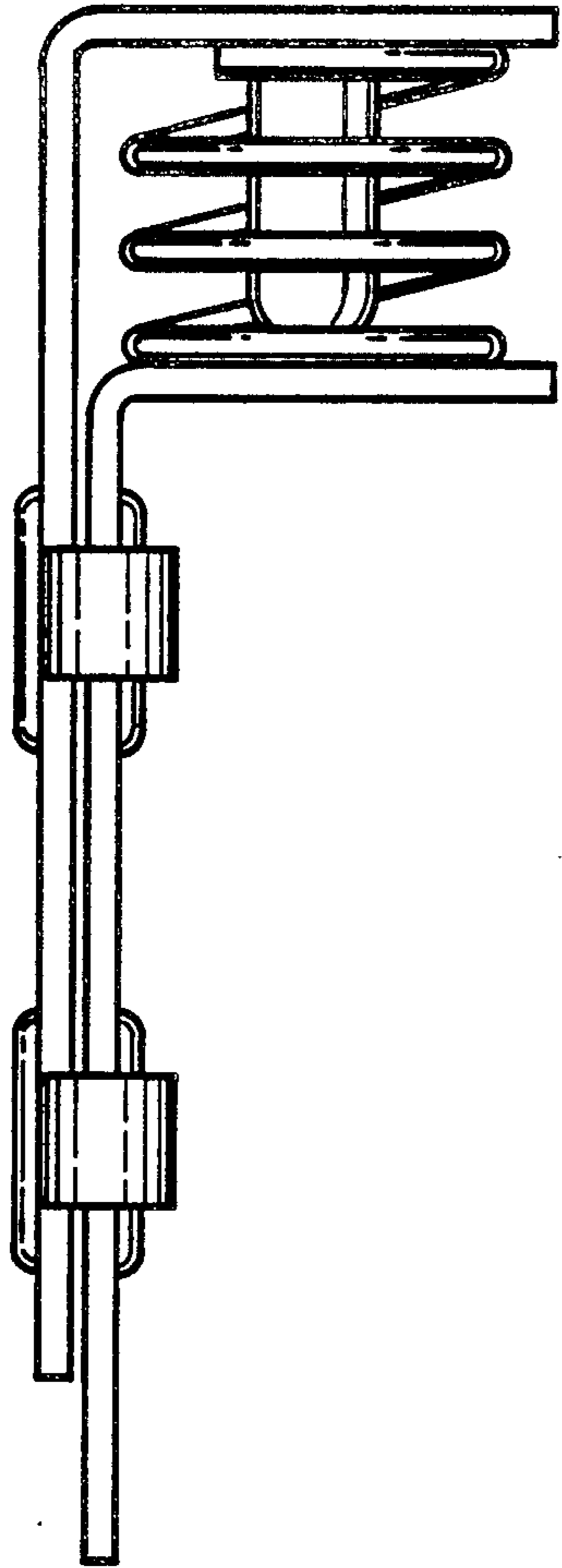

Fig. 1

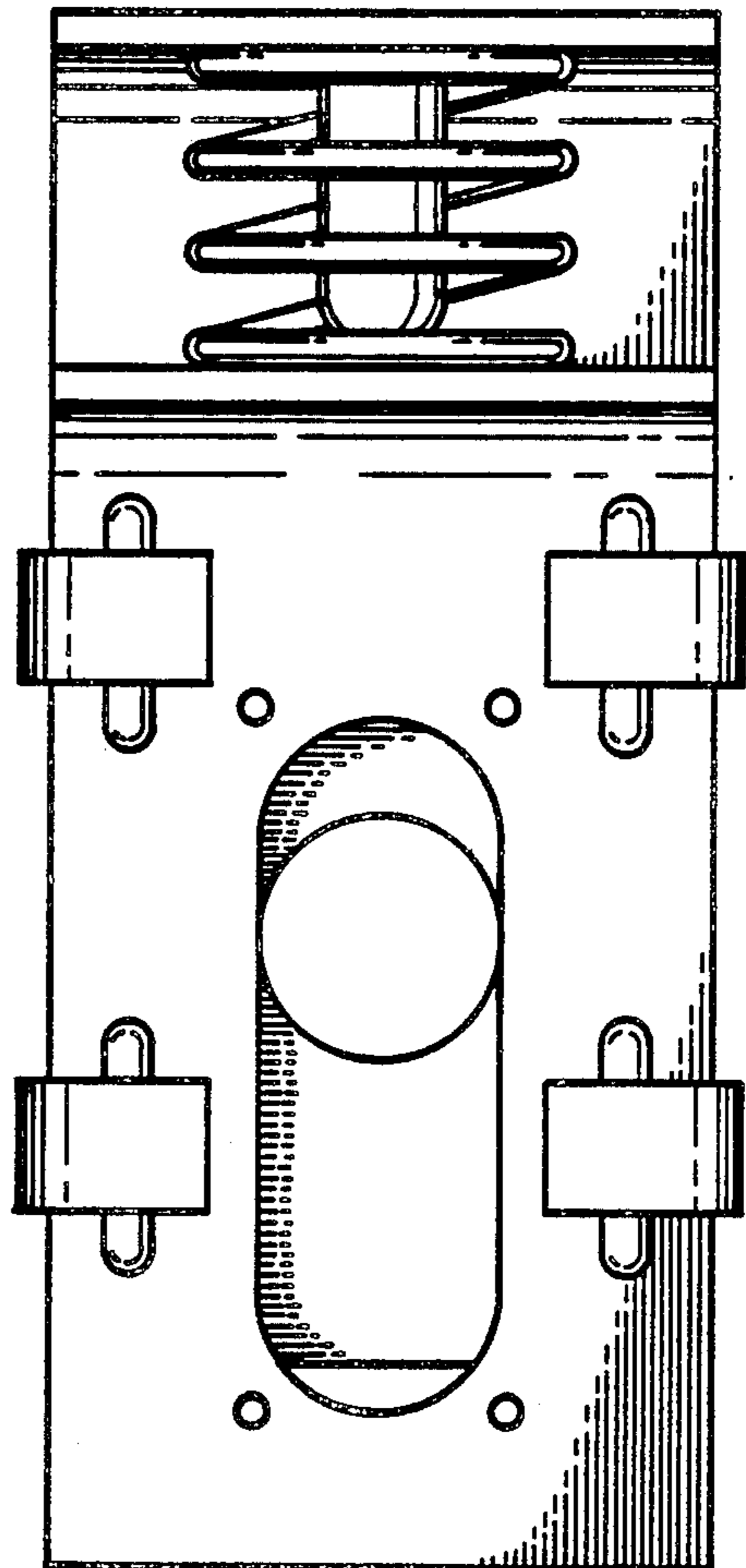

Fig. 2

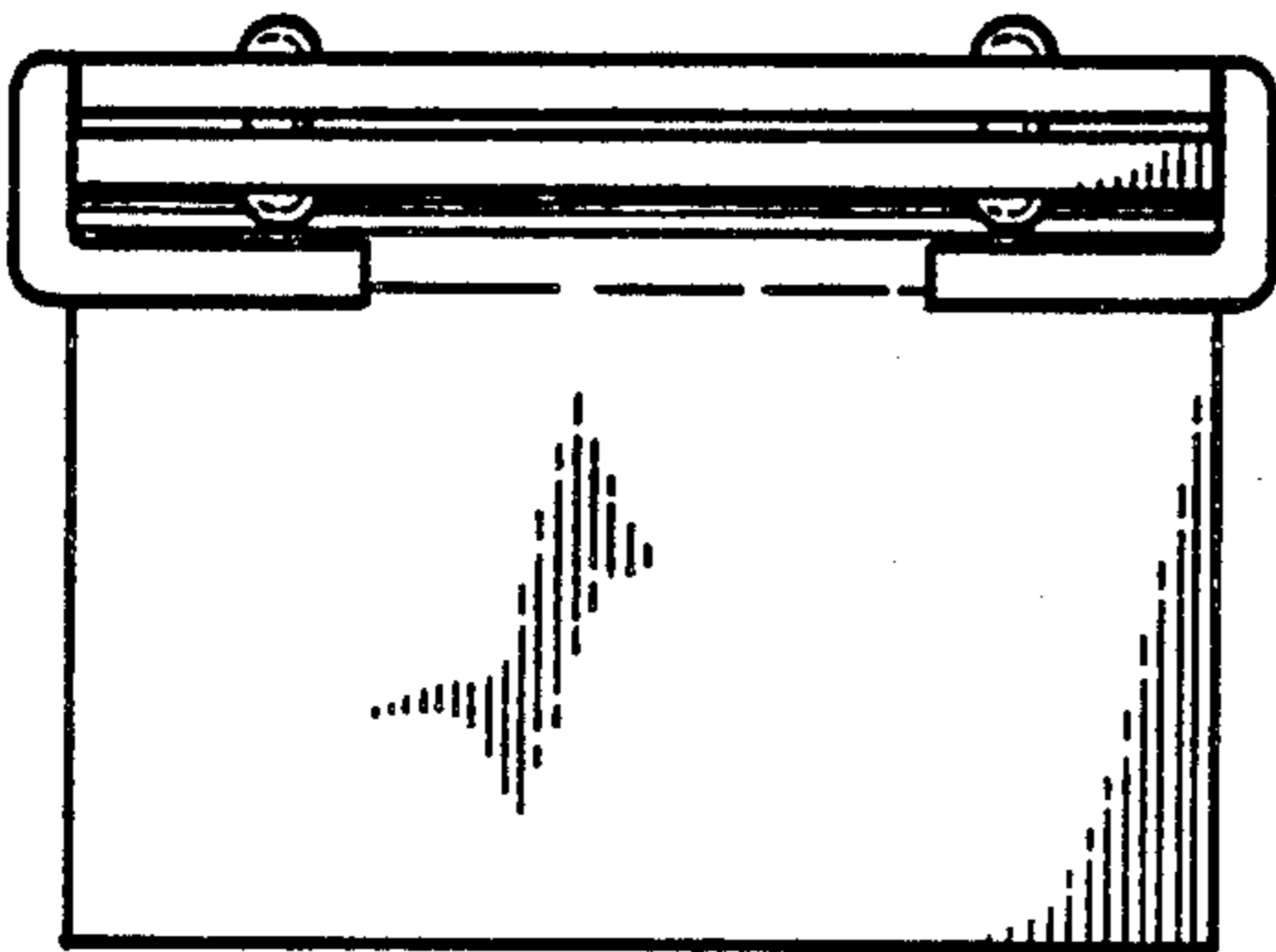

Fig. 3

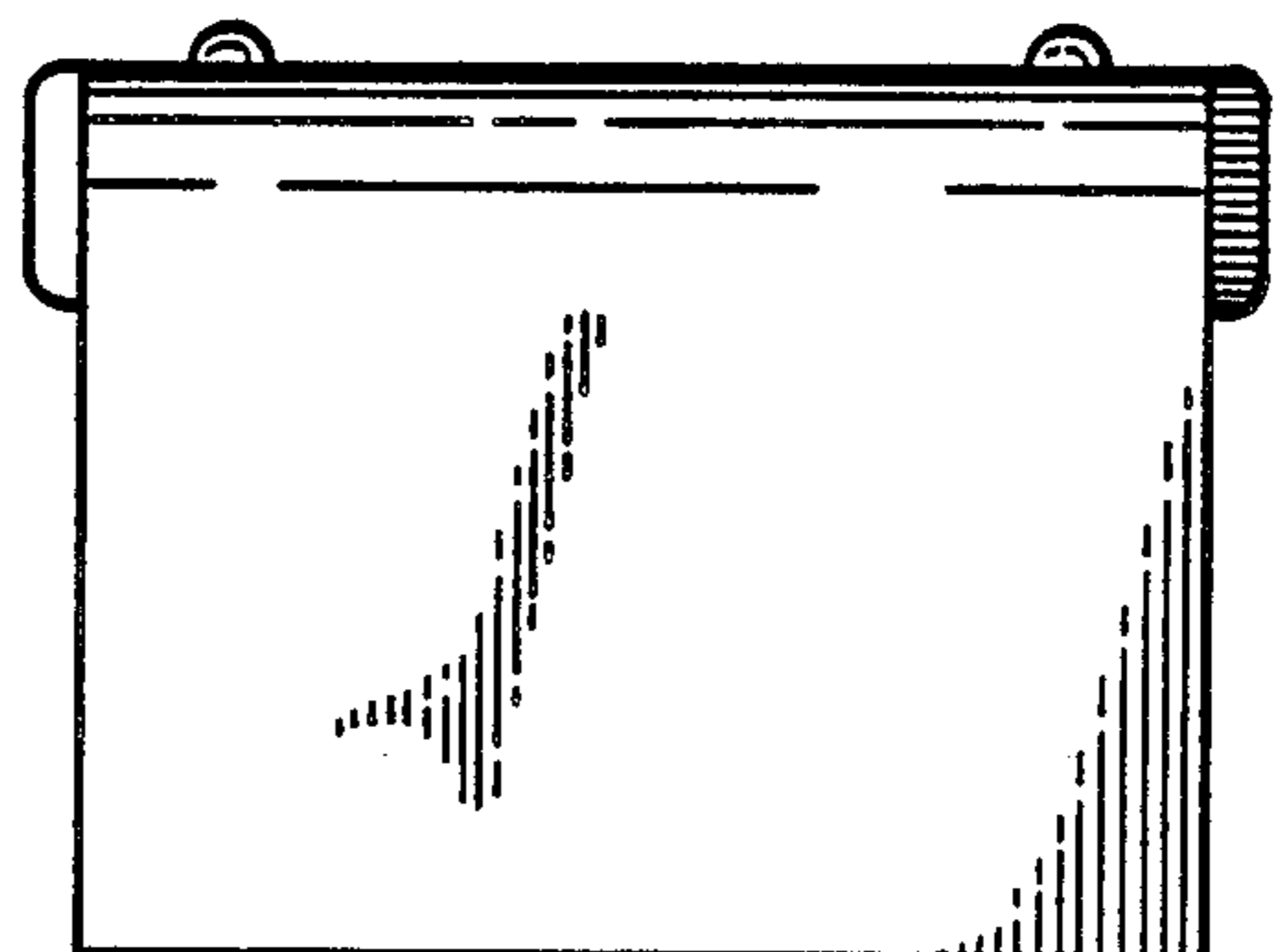

Fig. 4

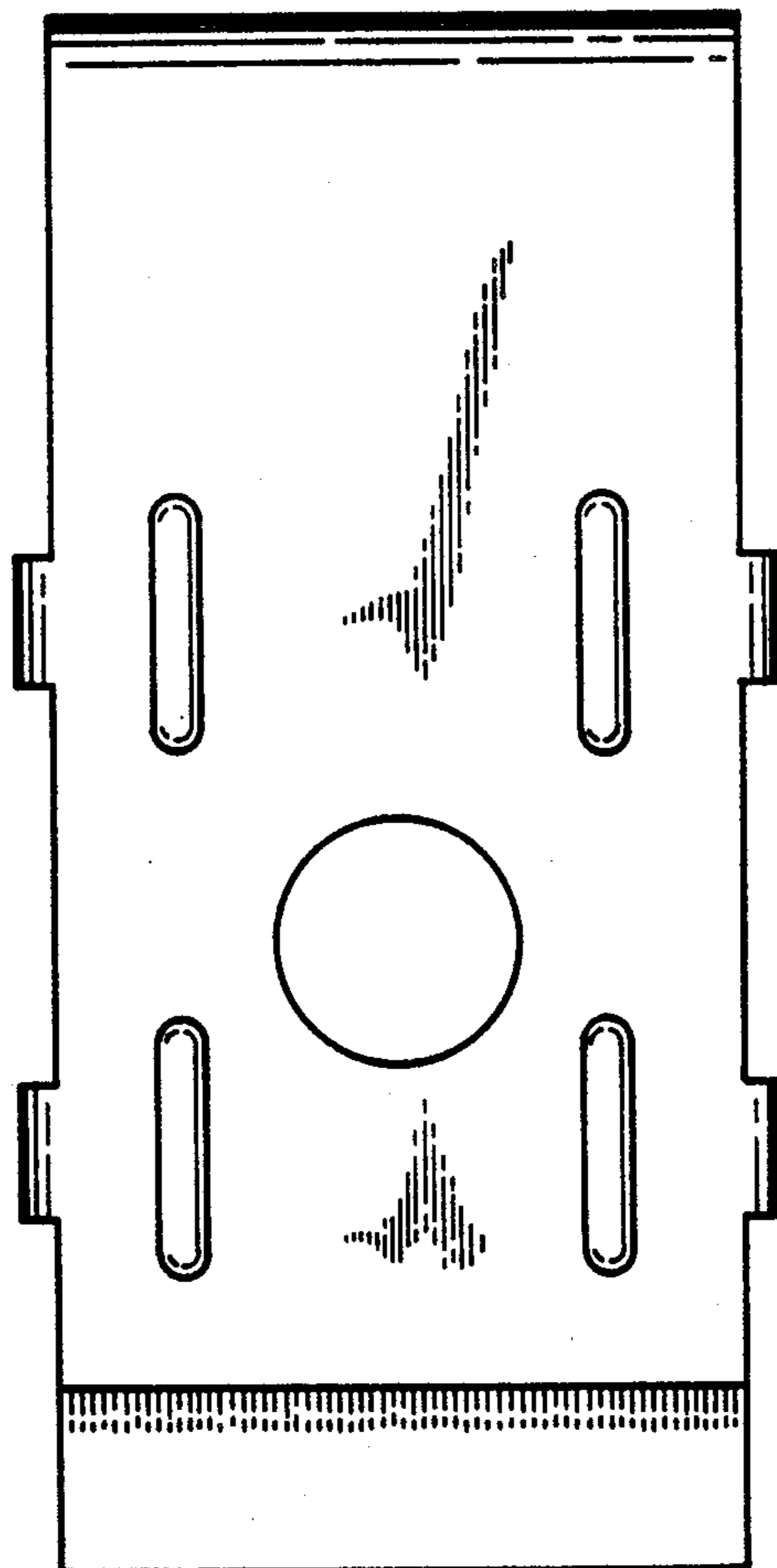

Fig. 5

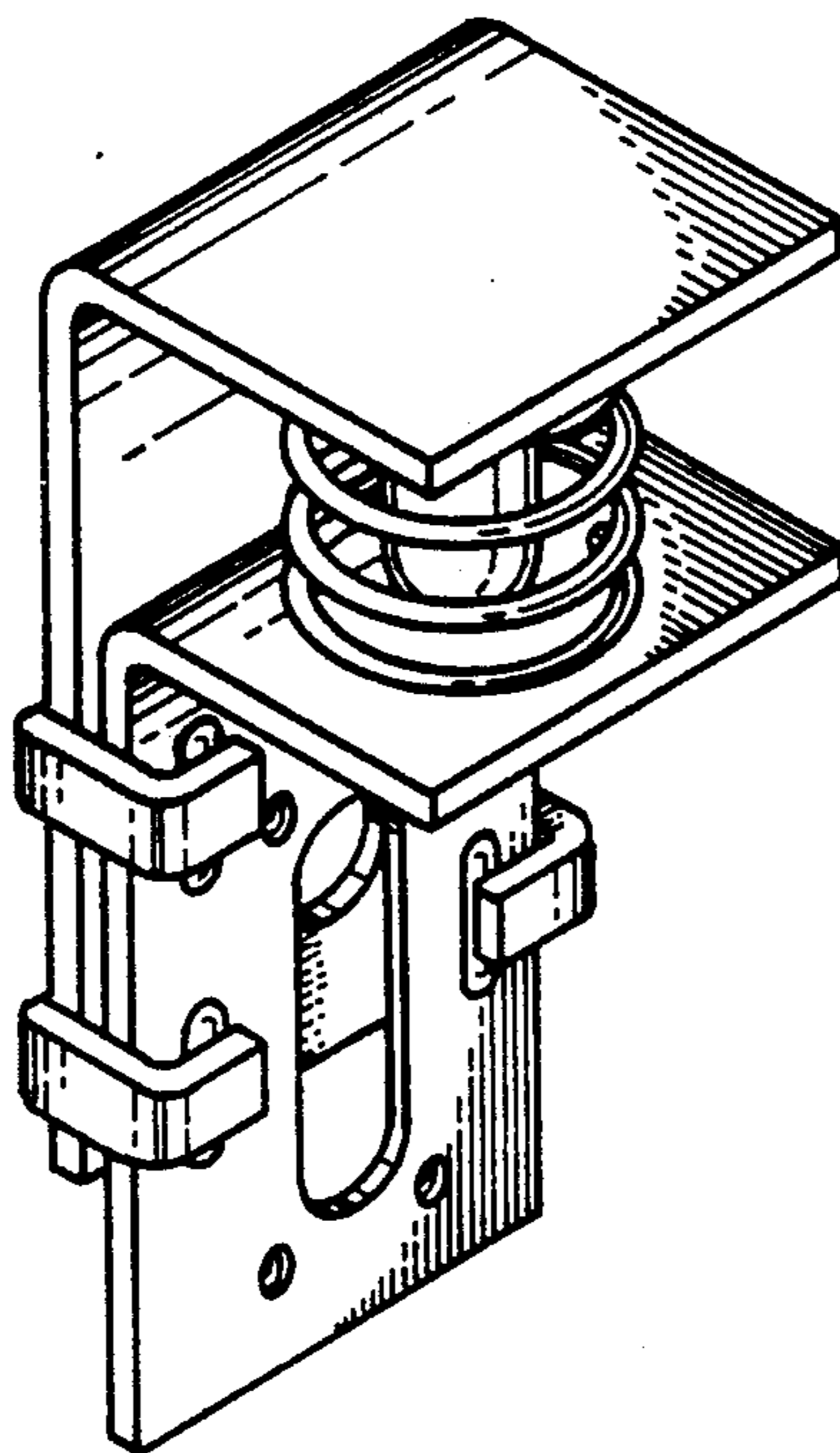

Fig. 6