

[54] VAN TOP LUGGAGE CARRIER OR SIMILAR ARTICLE

[75] Inventor: Delbert O. Littrell, Vandalia, Mich.

[73] Assignee: Bivouac Industries, Inc., Vandalia, Mich.

[\*\*] Term: 14 Years

[21] Appl. No.: 733,788

[22] Filed: May 14, 1985

[52] U.S. Cl. .... D12/157

[58] Field of Search ..... D12/156, 157; 296/26, 296/99 R, 156; 224/328

[56] References Cited

U.S. PATENT DOCUMENTS

D. 150,087	6/1948	Martin	.....	D12/157
D. 150,161	7/1948	Sanmori	.....	D12/91
D. 244,016	4/1977	Waldman	.....	D12/156
D. 253,104	10/1979	Vallee	.....	D12/157
D. 269,667	7/1983	Taylor et al.	.....	D12/157
D. 279,922	8/1985	Marovich	.....	D12/157
2,134,635	8/1938	LeBoeuf	.....	224/29
2,597,656	5/1952	Martin	.....	224/42.1
2,809,862	10/1957	Daniels	.....	296/44
2,903,296	9/1959	Barenyi	.....	296/44
2,938,749	5/1960	Podolan et al.	.....	296/44
2,963,314	12/1960	Richardson	.....	296/37
3,492,044	1/1970	Mycroft	.....	296/146
3,514,023	5/1970	Russell et al.	.....	224/42.1
3,861,572	1/1975	Norris et al.	.....	224/42.1 E
4,173,965	11/1979	Vallee et al.	.....	224/328
4,247,026	1/1981	Heifner et al.	.....	224/42.42
4,345,706	8/1982	Benit	.....	224/327
4,420,105	12/1983	Nepper	.....	224/328

OTHER PUBLICATIONS

R. V. Business, 7/84, p. 137, Van Top, top left side of page.

Primary Examiner—James M. Gandy  
Attorney, Agent, or Firm—Barnes & Thornburg

[57] CLAIM

The ornamental design for a van top luggage carrier or similar article, as shown and described.

DESCRIPTION

FIG. 1 is a perspective view of a van top luggage carrier showing my new design;  
 FIG. 2 is a left side elevation view thereof;  
 FIG. 3 is a rear elevation view thereof;  
 FIG. 4 is a front elevation view thereof;  
 FIG. 5 is a right side elevation view thereof;  
 FIG. 6 is a top plan view thereof;  
 FIG. 7 is a perspective thereof with the side doors and rear panel in open condition;  
 FIG. 8 is a left side elevation view of FIG. 7;  
 FIG. 9 is a front elevation view of FIG. 7;  
 FIG. 10 is a perspective view of a van top luggage carrier showing a second embodiment of my new design;  
 FIG. 11 is a left side elevation view of FIG. 10 it being understood that the right side is a mirror image thereof;  
 FIG. 12 is a front elevation view of FIG. 10;  
 FIG. 13 is a rear perspective view of FIG. 1 with the rear panel in open condition.  
 The top and rear views of the second embodiment of the design are substantially the same as those of the first embodiment shown in FIGS. 6 and 3, respectively. The broken lines shown in FIGS. 1, 7, 10, and 13 are for illustrative purposes only and form no part of the claimed design.

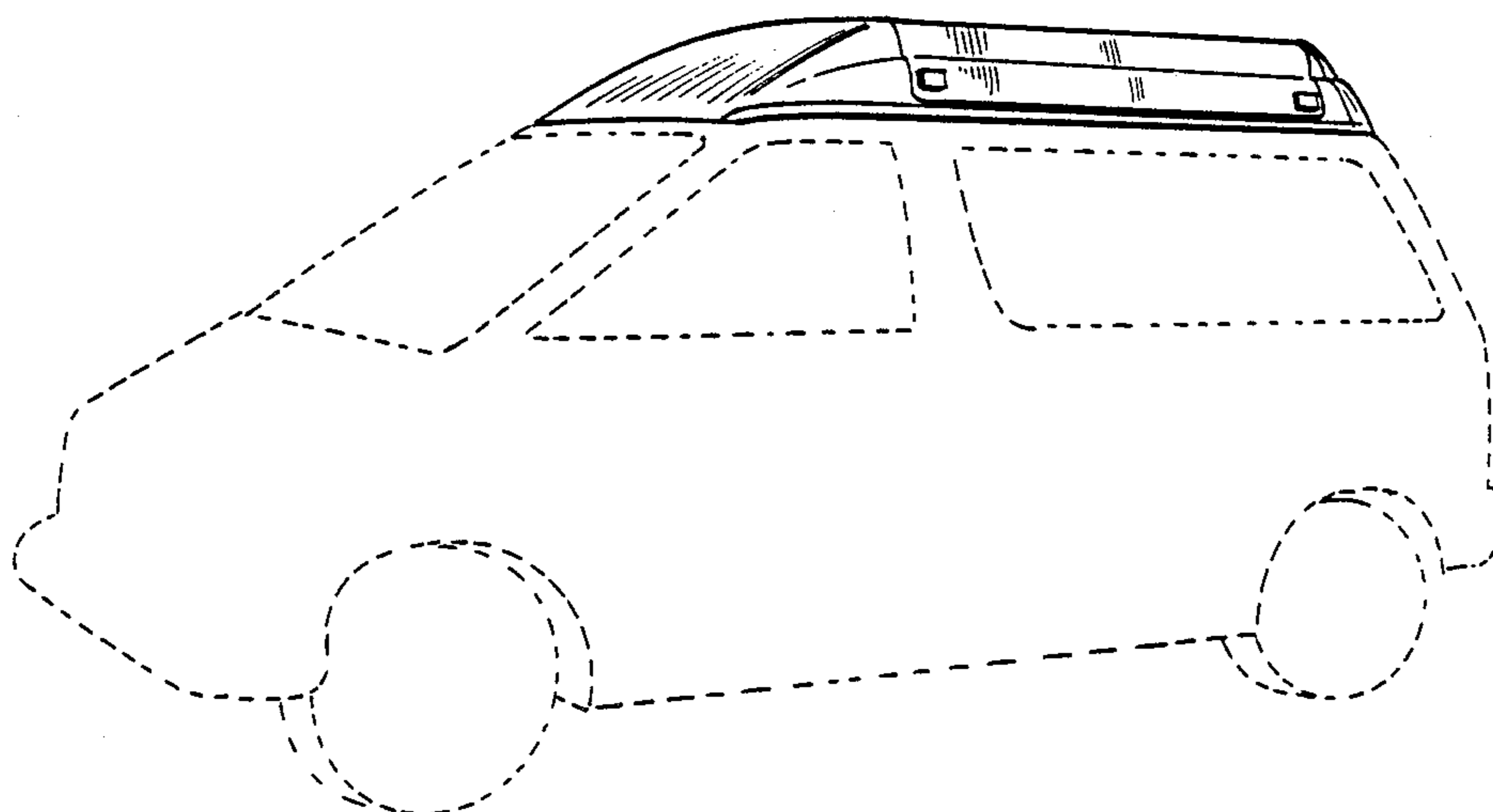

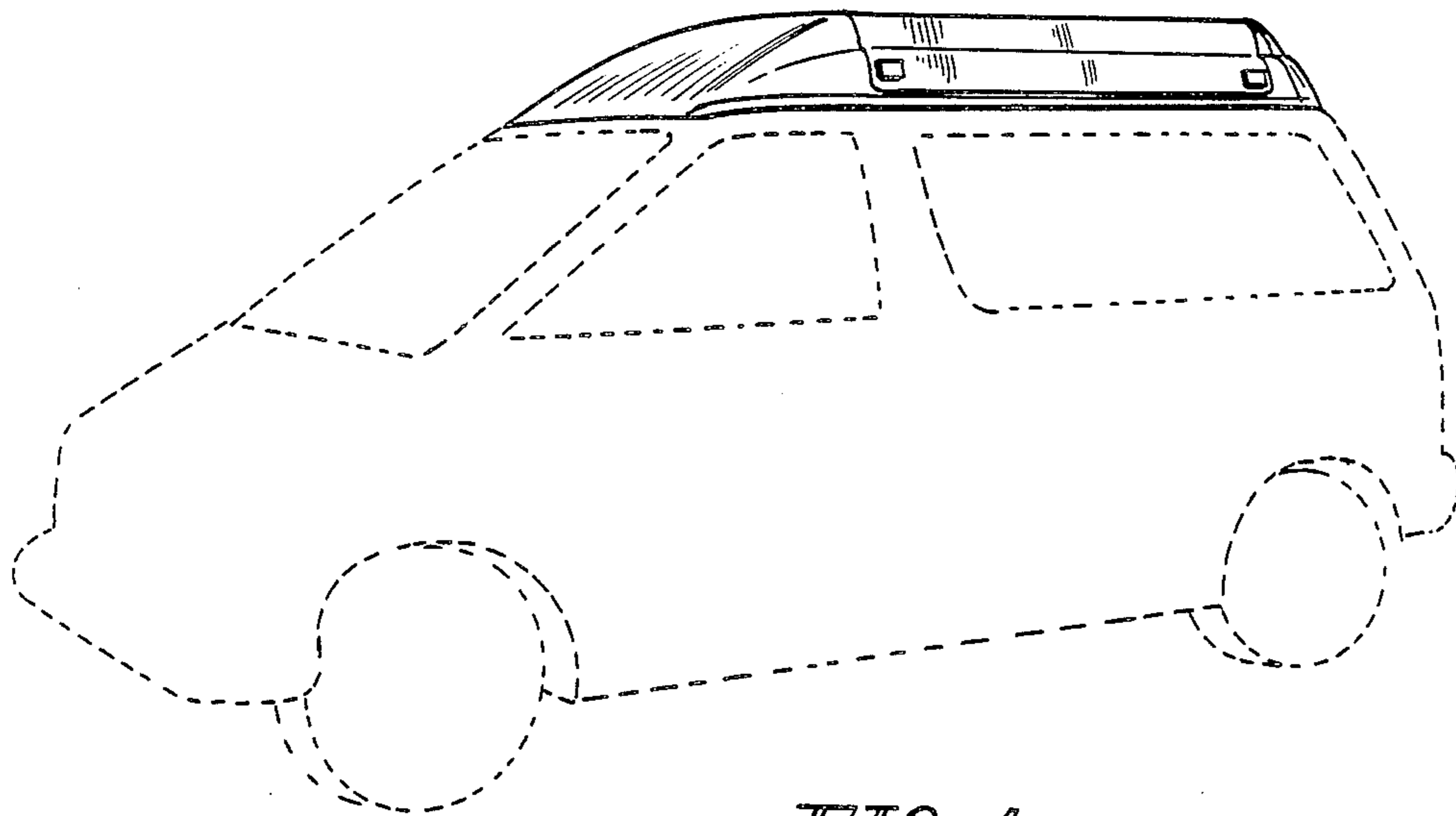

FIG. 1

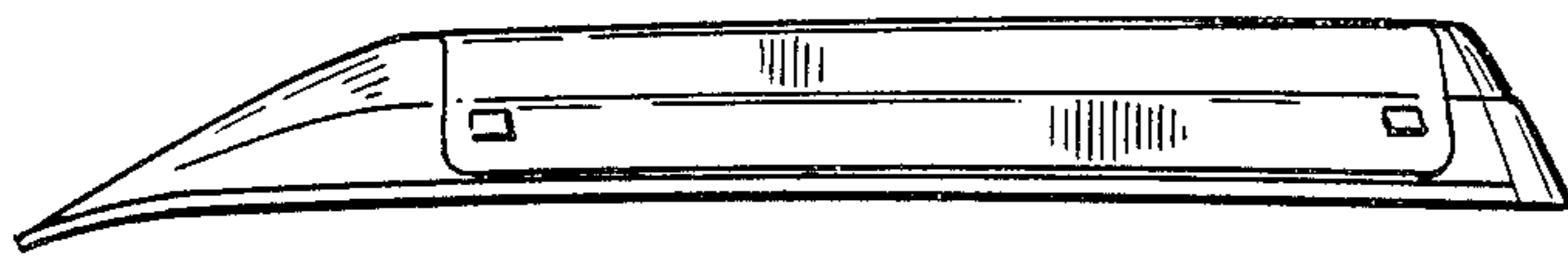

FIG. 2

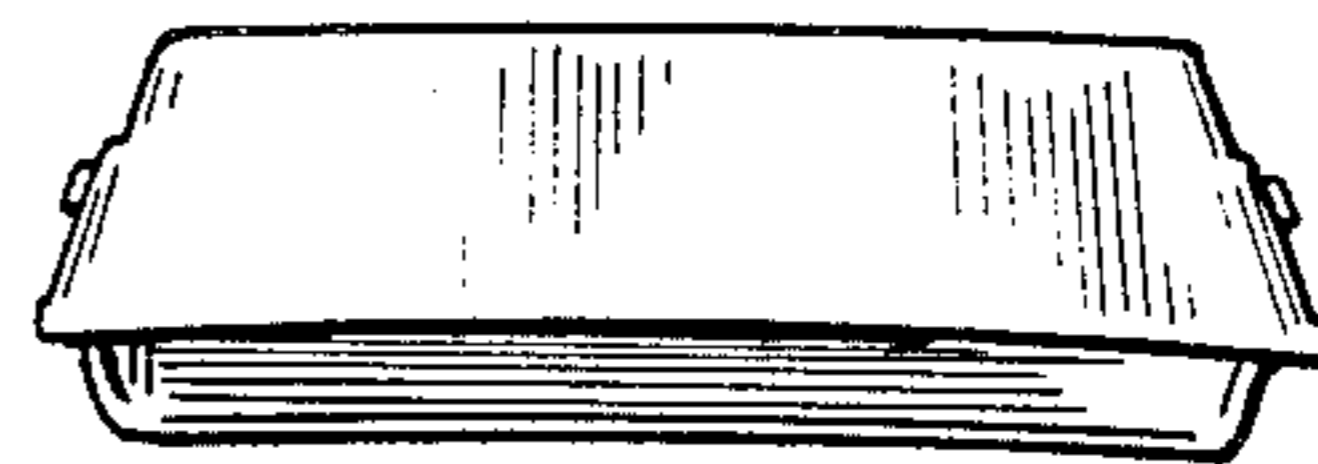

FIG. 3

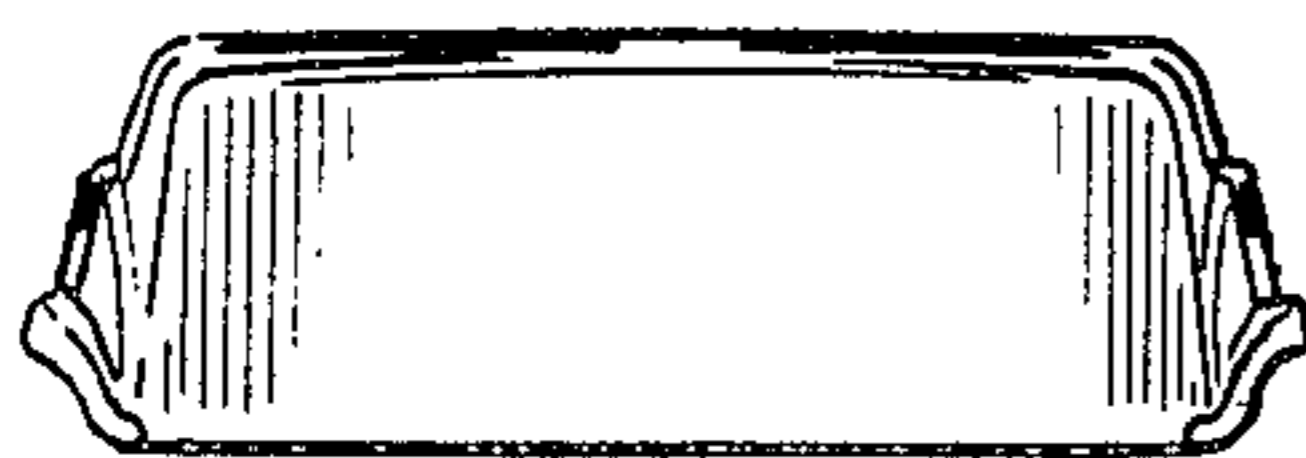

FIG. 4

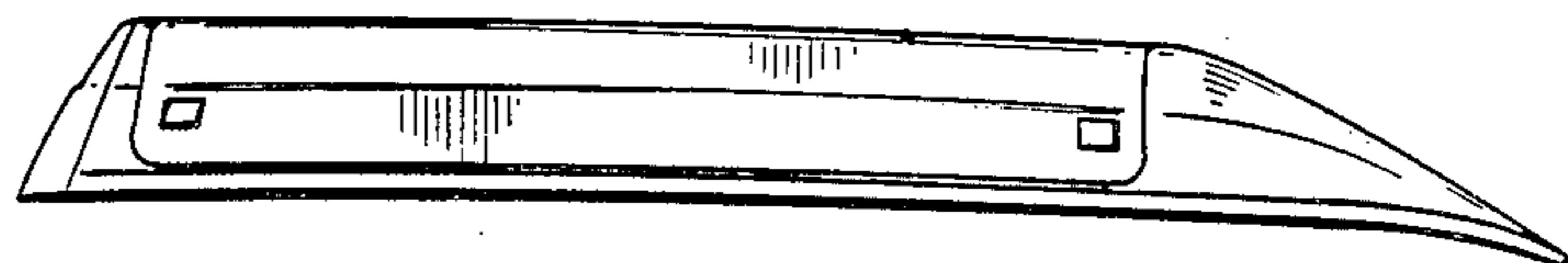

FIG. 5

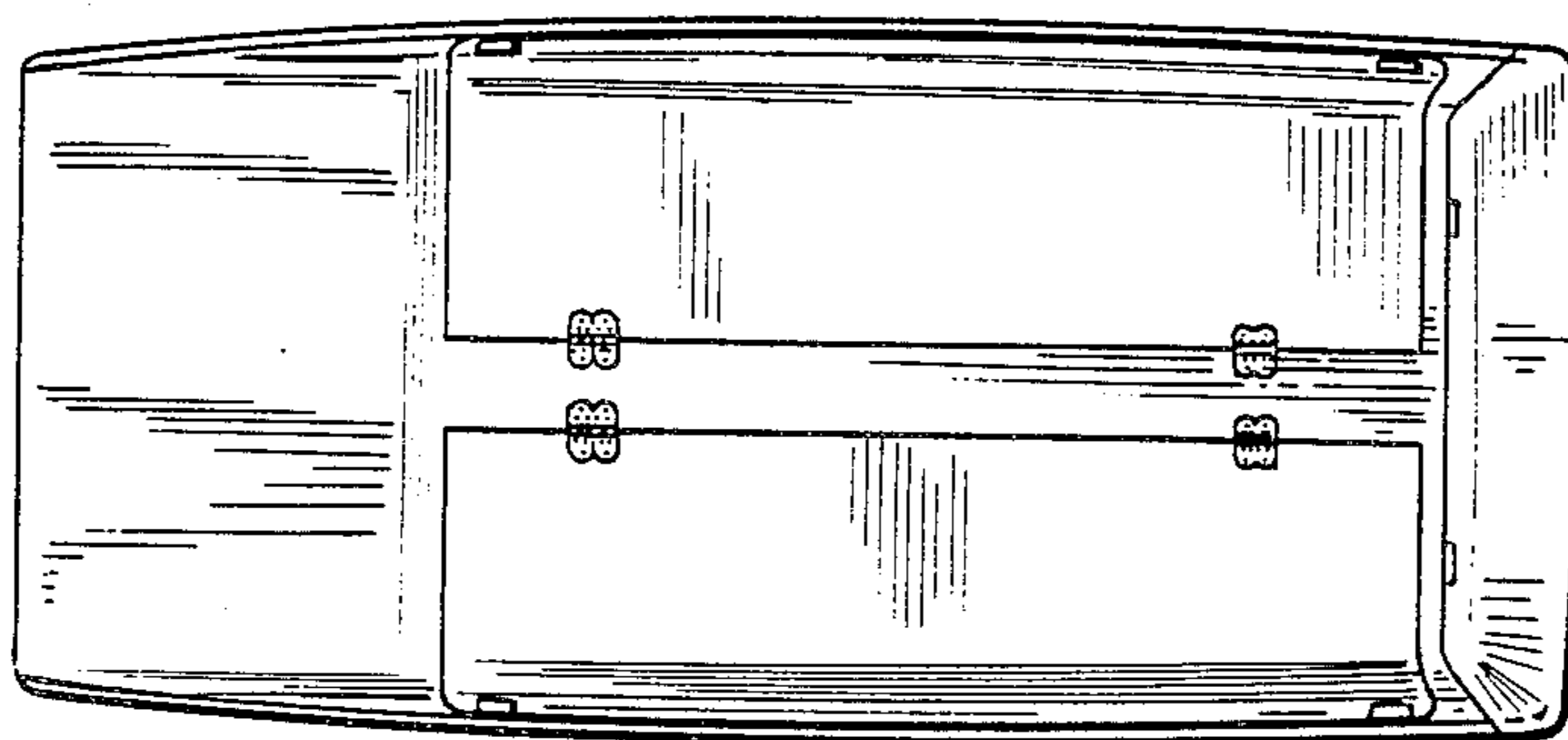

FIG. 6

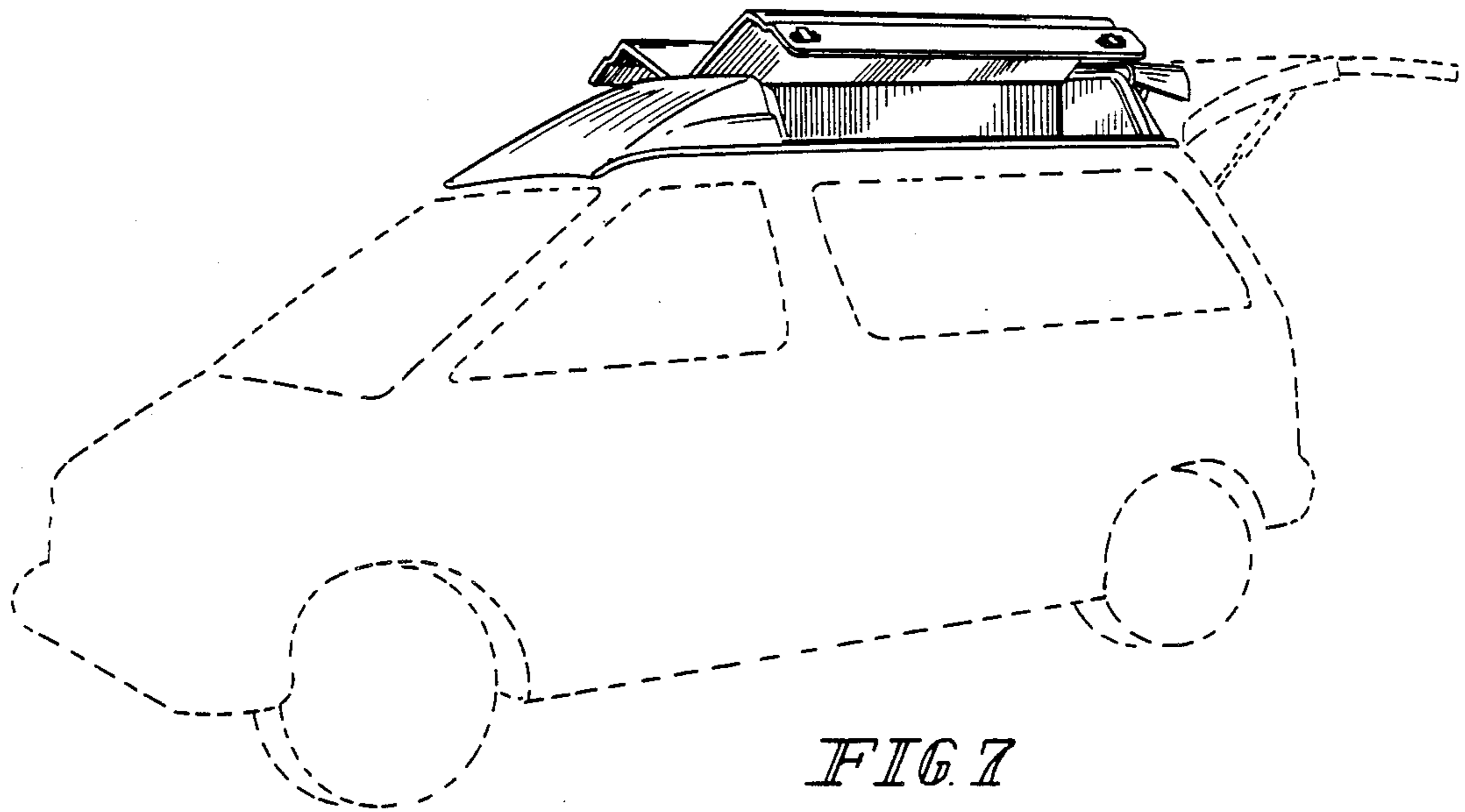

FIG. 7

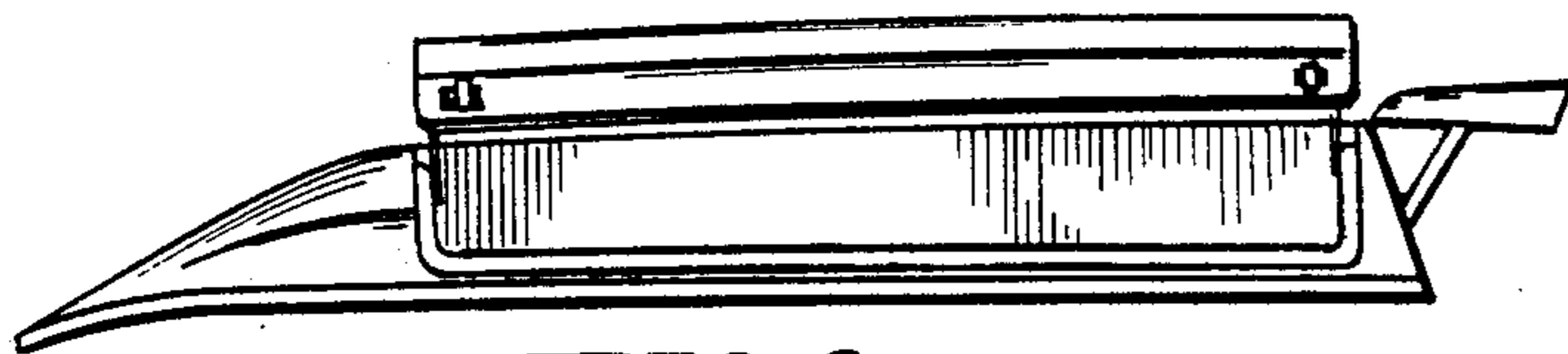

FIG. 8

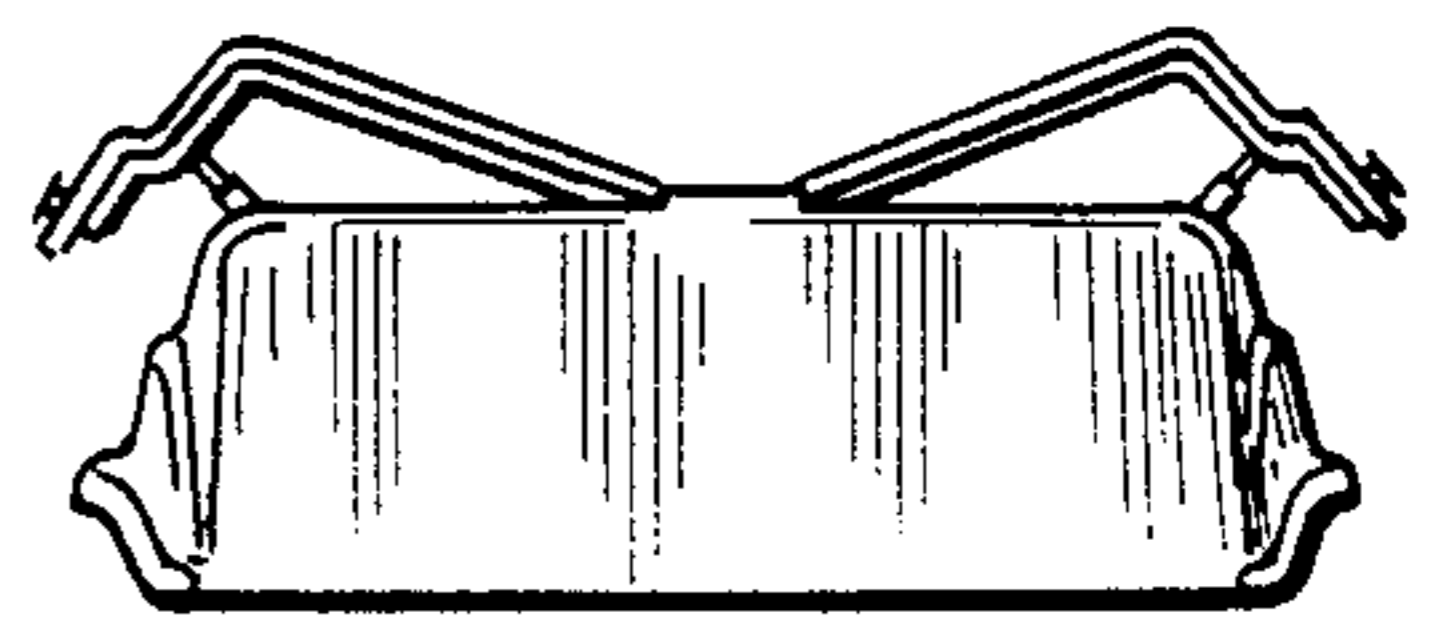

FIG. 9

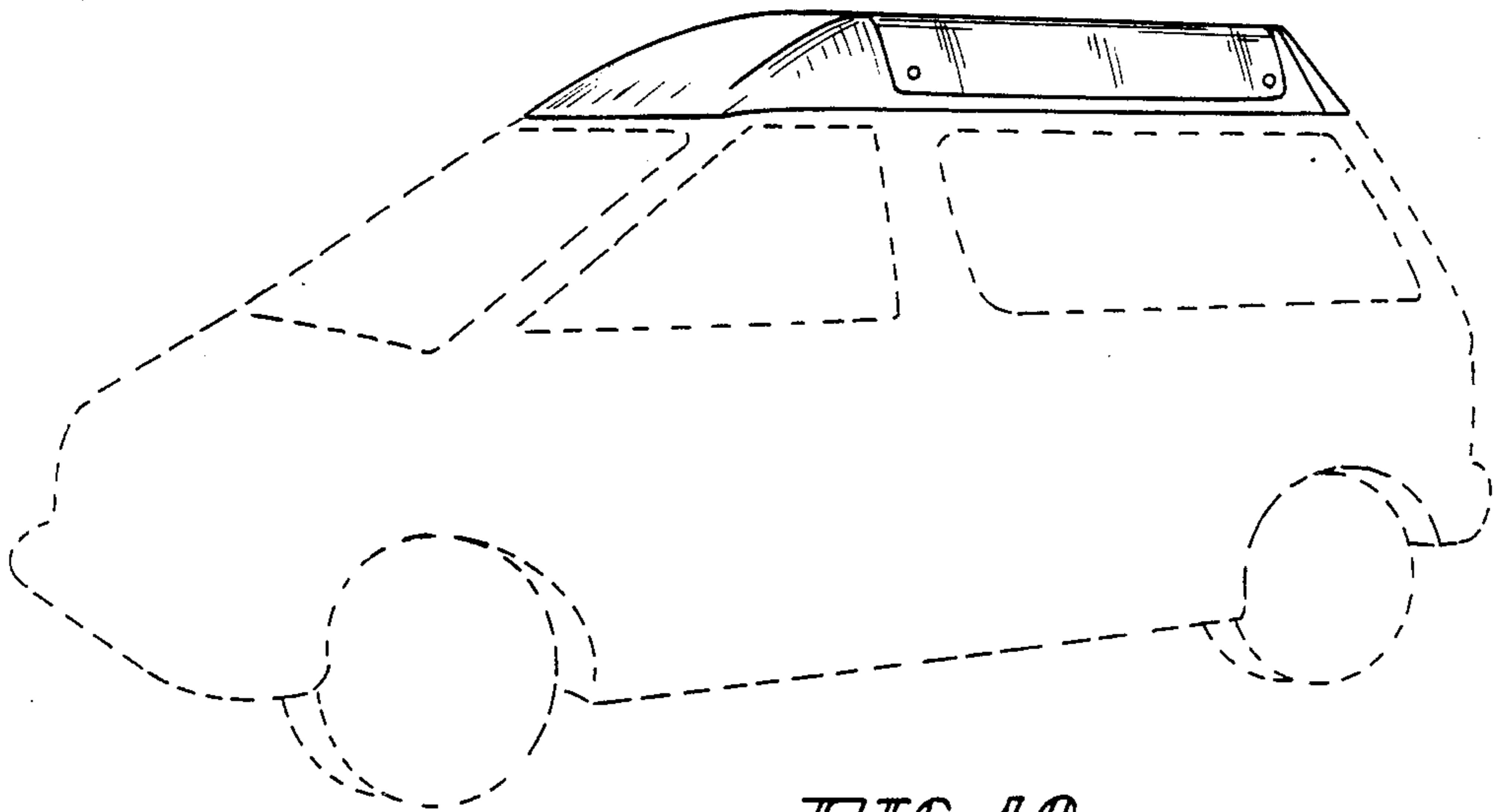

FIG. 10

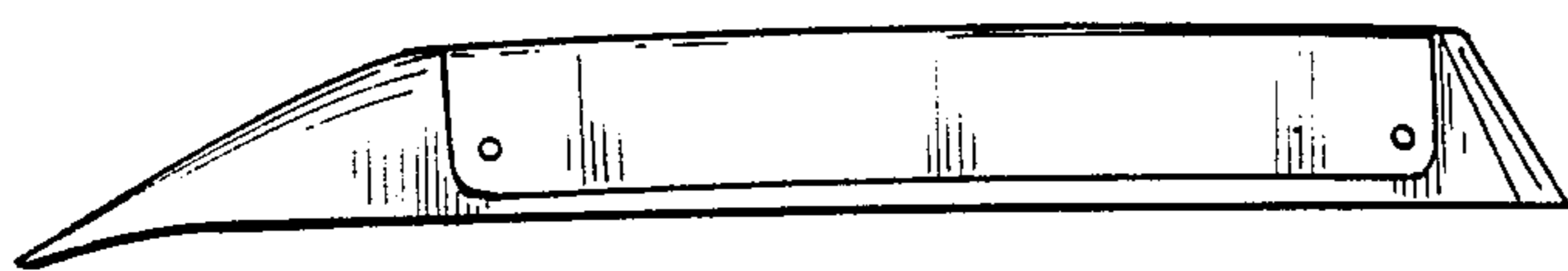

FIG. 11

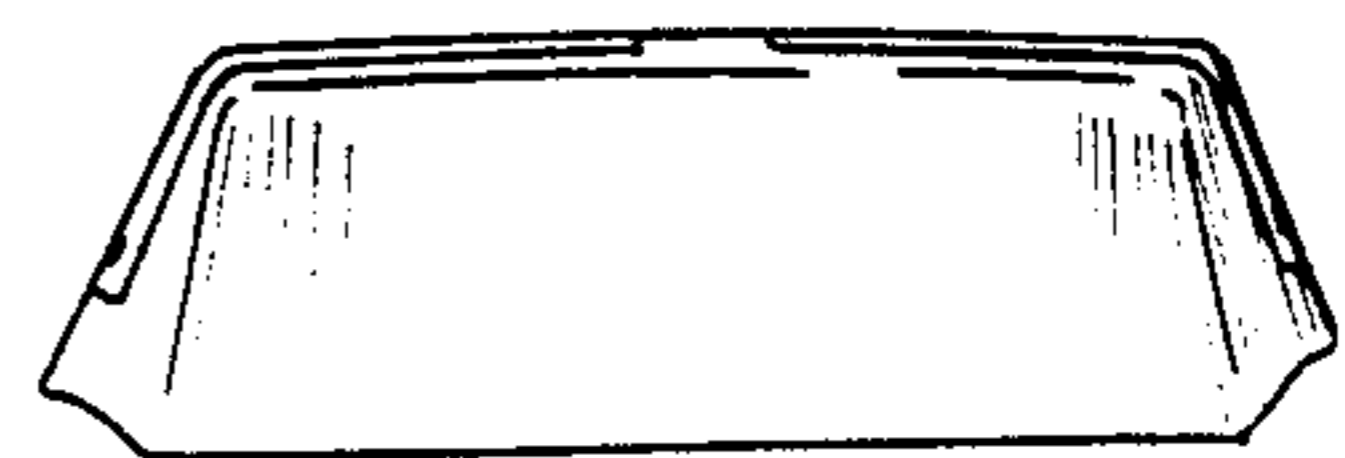
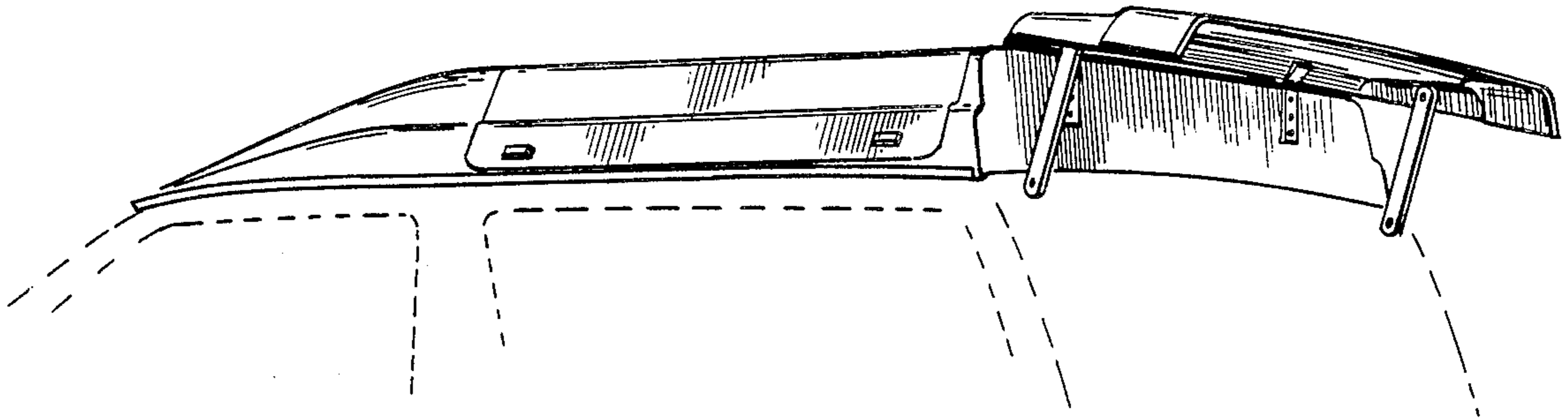

FIG. 12



*FIG. 13*