

United States Patent [19]

Lipski

[11] Patent Number: Des. 295,595

[45] Date of Patent: ** May 10, 1988

[54] SAFETY SIDE RAIL FOR A CHILD'S BED

[76] Inventor: Mordechai Lipski, 11 Kashani Street,
Tel Aviv, Israel

[**] Term: 14 Years

[21] Appl. No.: 719,748

[22] Filed: Apr. 4, 1985

[30] Foreign Application Priority Data

Dec. 31, 1984 [IL] Israel 10259

[52] U.S. Cl. D6/505

[58] Field of Search D6/382, 393, 394, 395,
D6/505, 503, 506, 507, 508, 390, 391; 5/331

[56] References Cited

U.S. PATENT DOCUMENTS

D. 226,364 2/1973 Thomas D6/503

D. 226,419 3/1973 Thomas D6/503
D. 226,513 3/1973 Thomas D6/503
D. 247,307 2/1978 Johansson D6/390 X
D. 272,395 1/1984 Russo D6/391
2,618,787 11/1952 Dickson D6/391 X
2,904,799 9/1959 Berlin 5/331

Primary Examiner—Bruce W. Dunkins
Attorney, Agent, or Firm—Toren, McGeady &
Associates

[57] CLAIM

The ornamental design for a safety side rail for a child's bed, as shown.

DESCRIPTION

FIG. 1 is a front perspective view of a safety side rail for a child's bed showing my design;
FIG. 2 is a front elevational view;
FIG. 3 is a rear elevational view;
FIG. 4 is a top plan view.

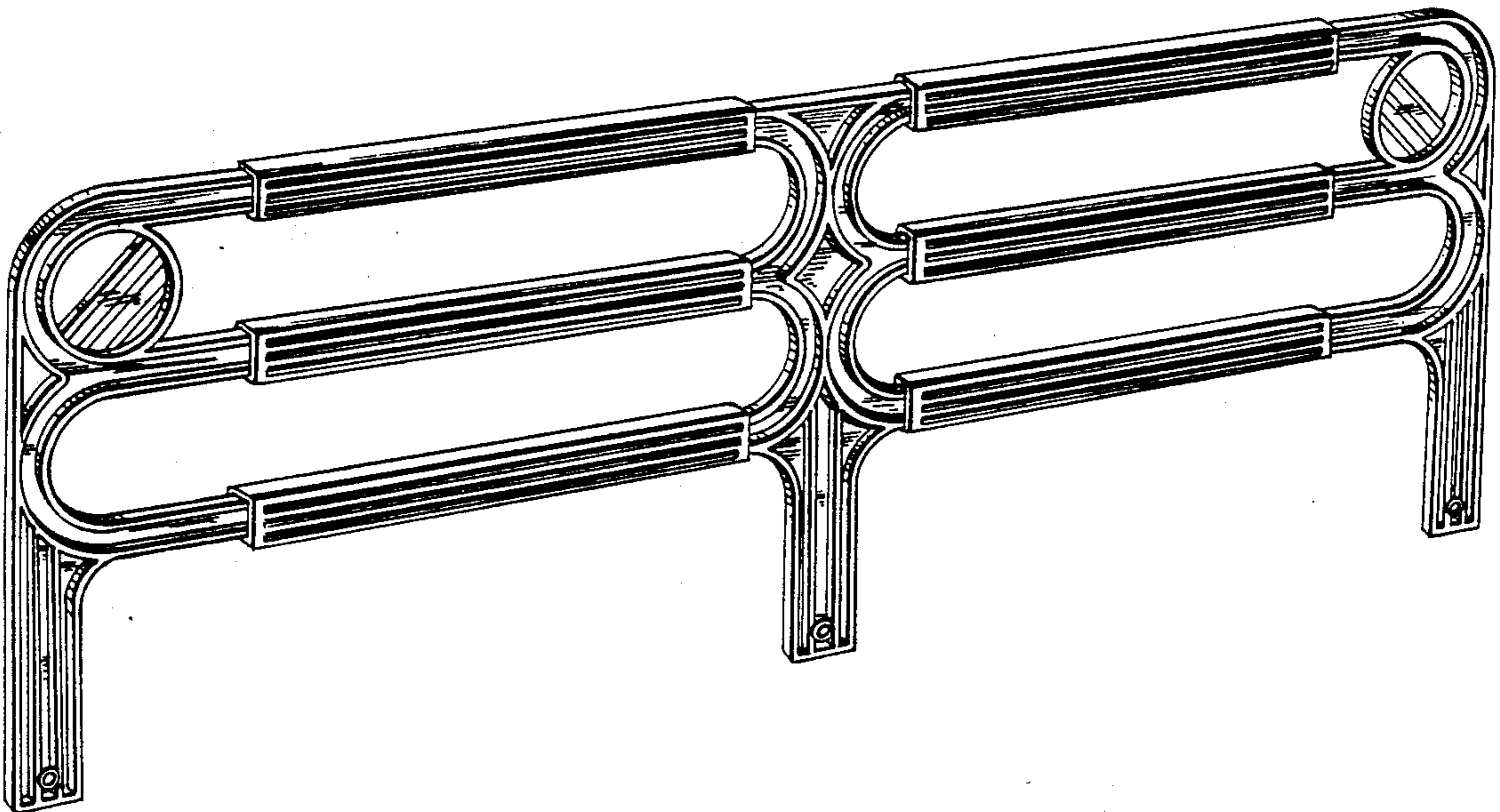

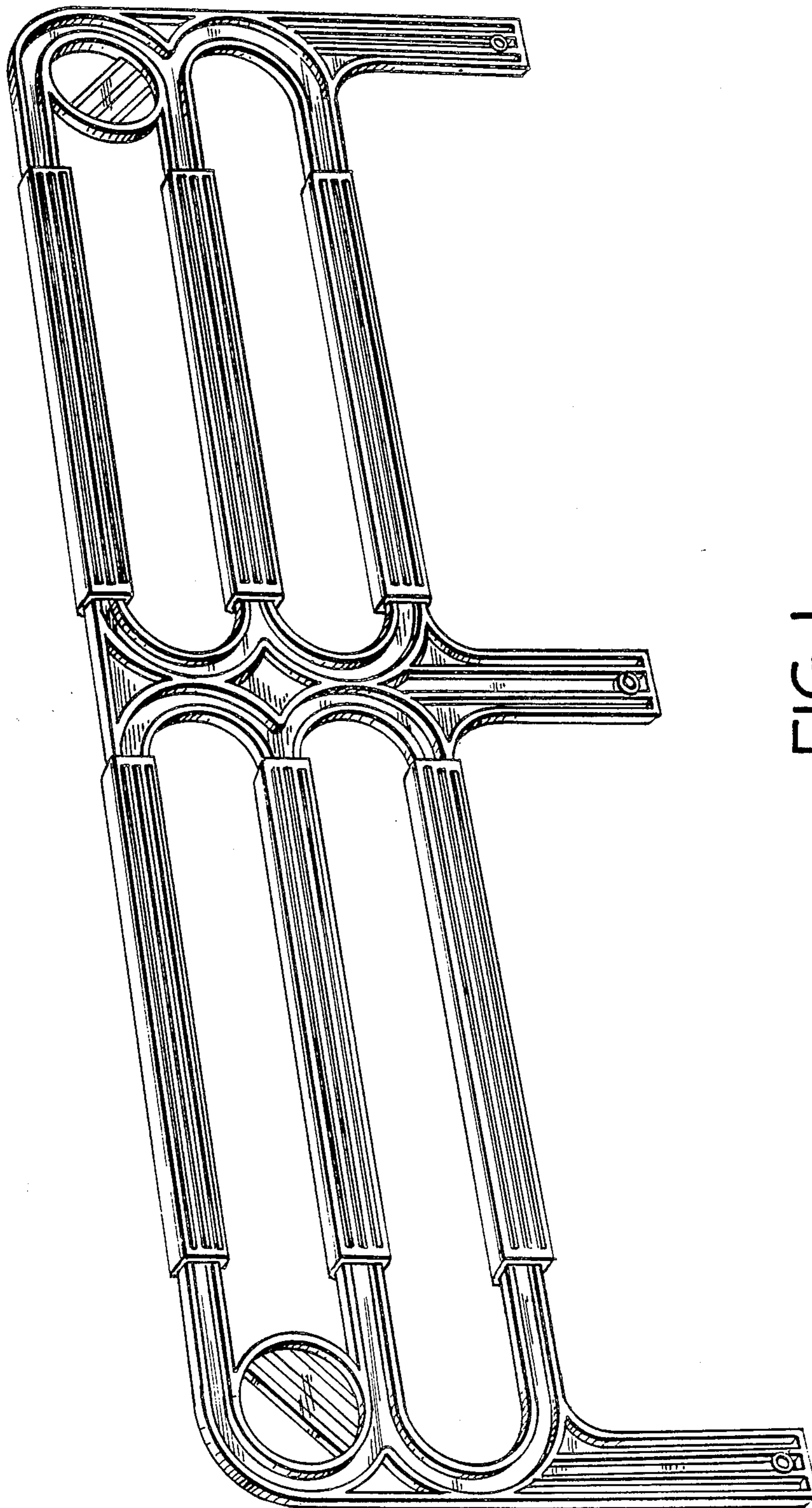

FIG. 1

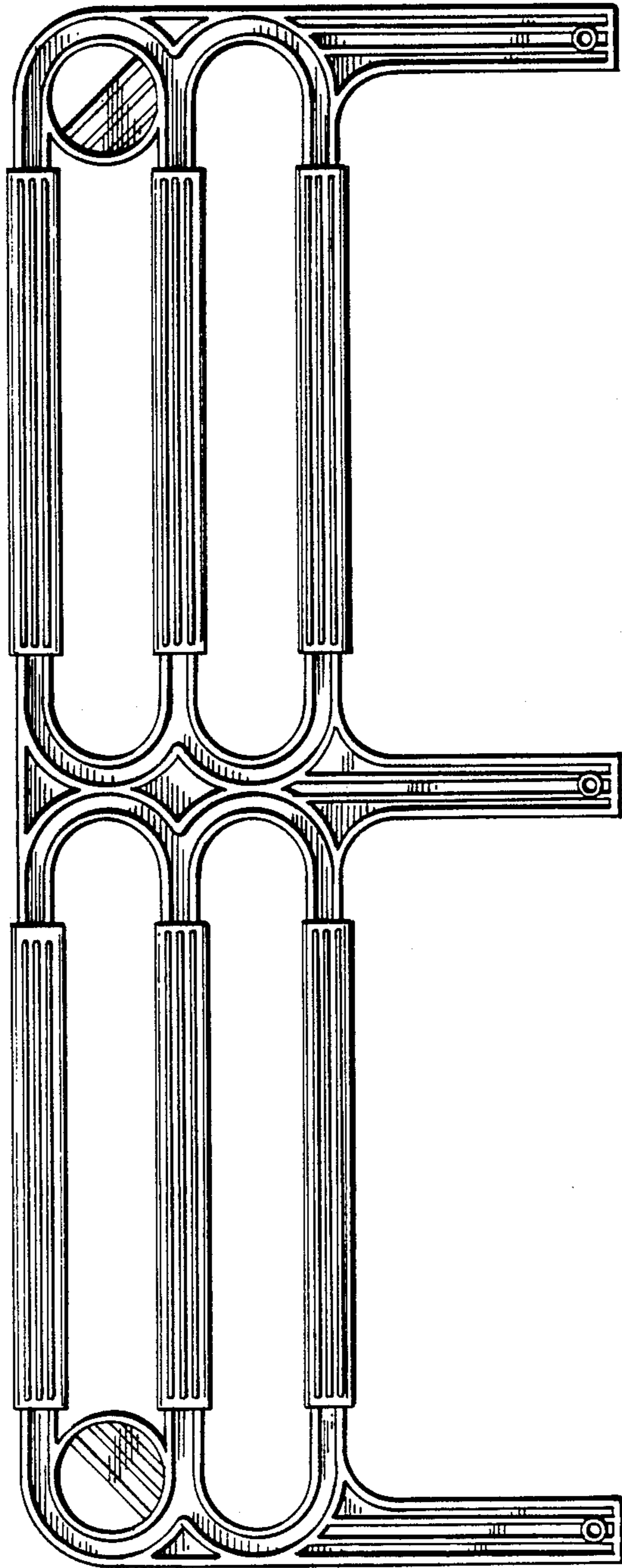

FIG.2

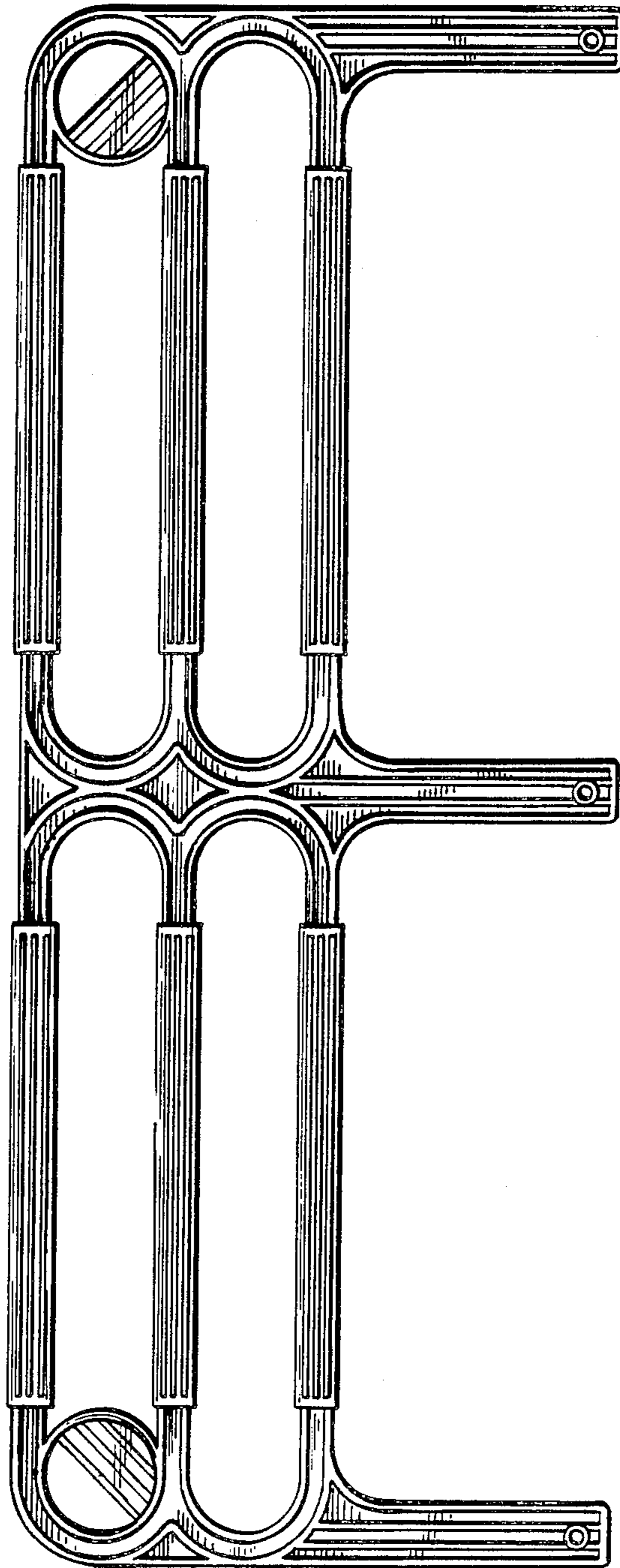

FIG. 3



FIG. 4



FIG. 5

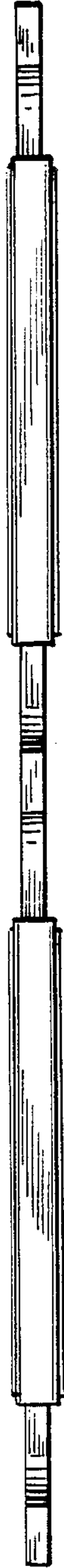

FIG. 6