

[54] WHEEL NUT

[75] Inventors: Louis D. Carlo, Cleveland, Ohio; Dann T. Deaver, Harper Woods, Mich.

[73] Assignee: Mr. Gasket Company, Cleveland, Ohio

[**] Term: 14 Years

[21] Appl. No.: 707,944

[22] Filed: Mar. 4, 1985

[52] U.S. Cl. D8/397

[58] Field of Search D8/397, 399; 301/9 G, 301/9 CN, 10 R, 10 DC, 37 AT; 411/427, 429

[56] References Cited

U.S. PATENT DOCUMENTS

- D. 170,408 9/1953 Gries D8/397
- 1,830,787 11/1931 Ferry 411/429

- 2,375,325 5/1945 Robertson 411/432
- 3,073,650 1/1963 Holbrow 301/9 G
- 4,354,711 10/1982 Main 301/9 CN
- 4,591,211 5/1986 Browning et al. 301/9 G

Primary Examiner—B. J. Bullock
Attorney, Agent, or Firm—Body, Vickers & Daniels

[57] CLAIM

The ornamental design for a wheel nut, as shown and described.

DESCRIPTION

- FIG. 1 is a perspective view of a wheel nut showing my new design;
- FIG. 2 is a right side elevational view thereof, the left side being a mirror image;
- FIG. 3 is a top plan view thereof, the bottom being a mirror image;
- FIG. 4 is a front elevational view thereof; and,
- FIG. 5 is a rear elevational view thereof.

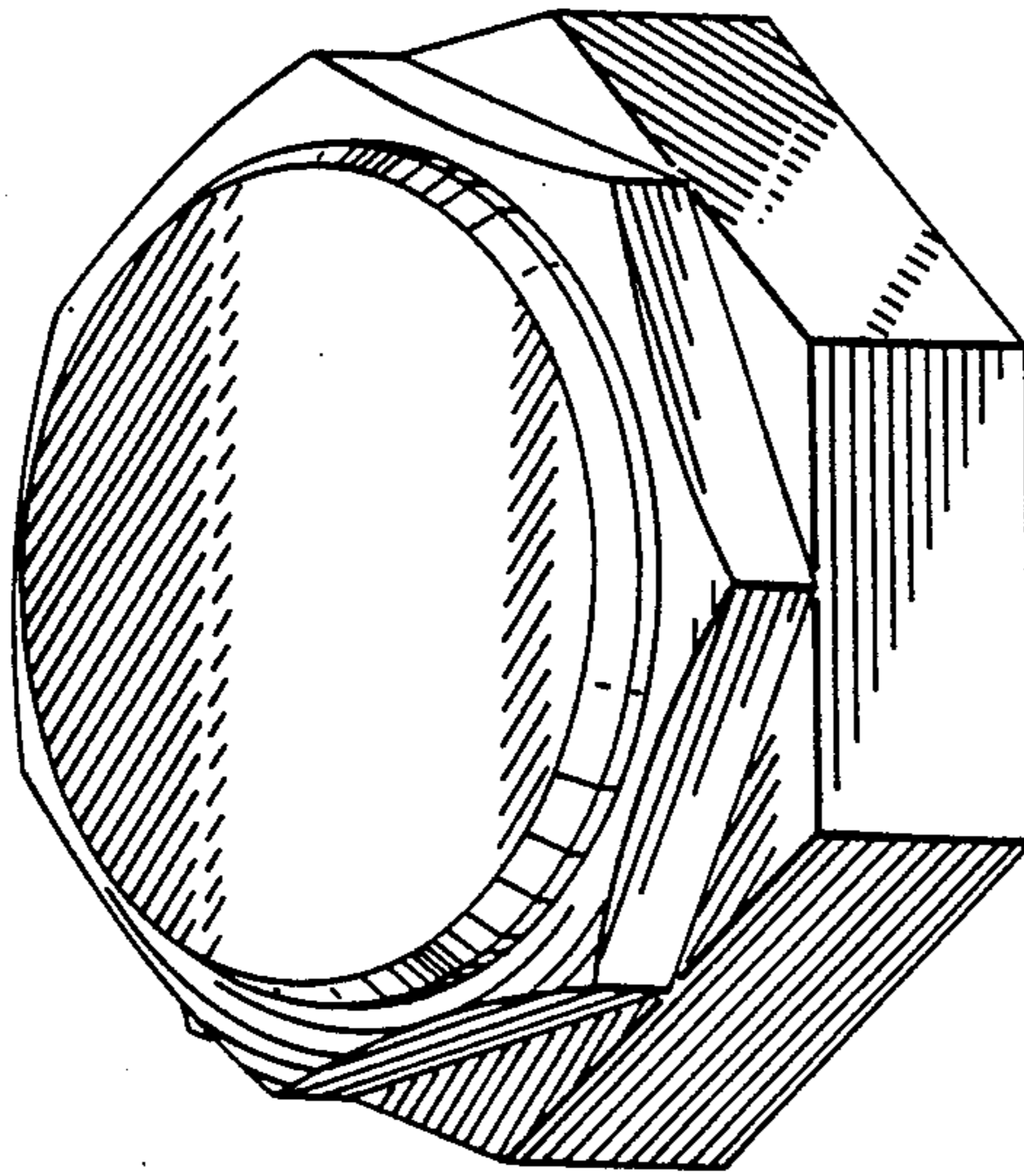

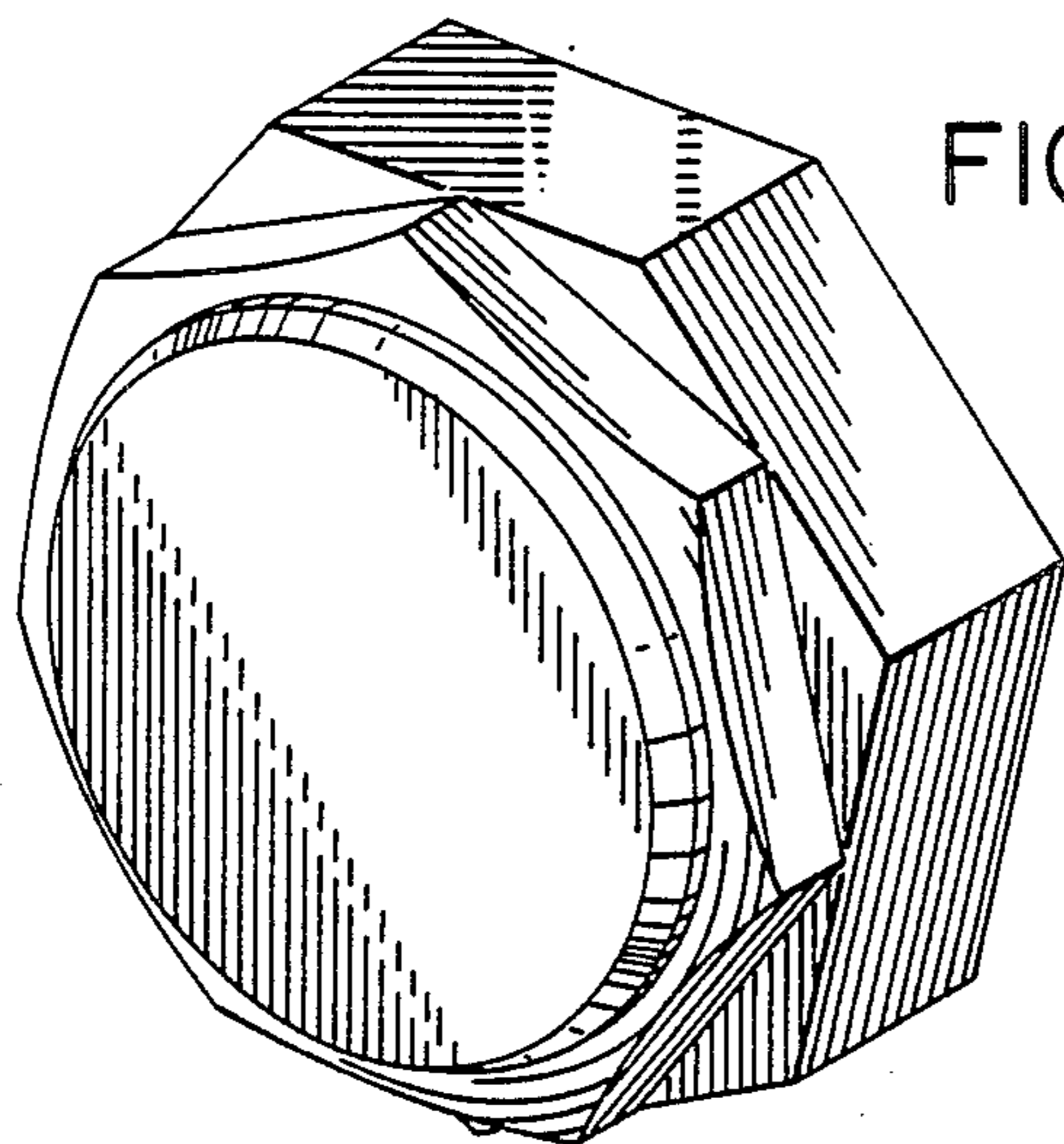

FIG. 1

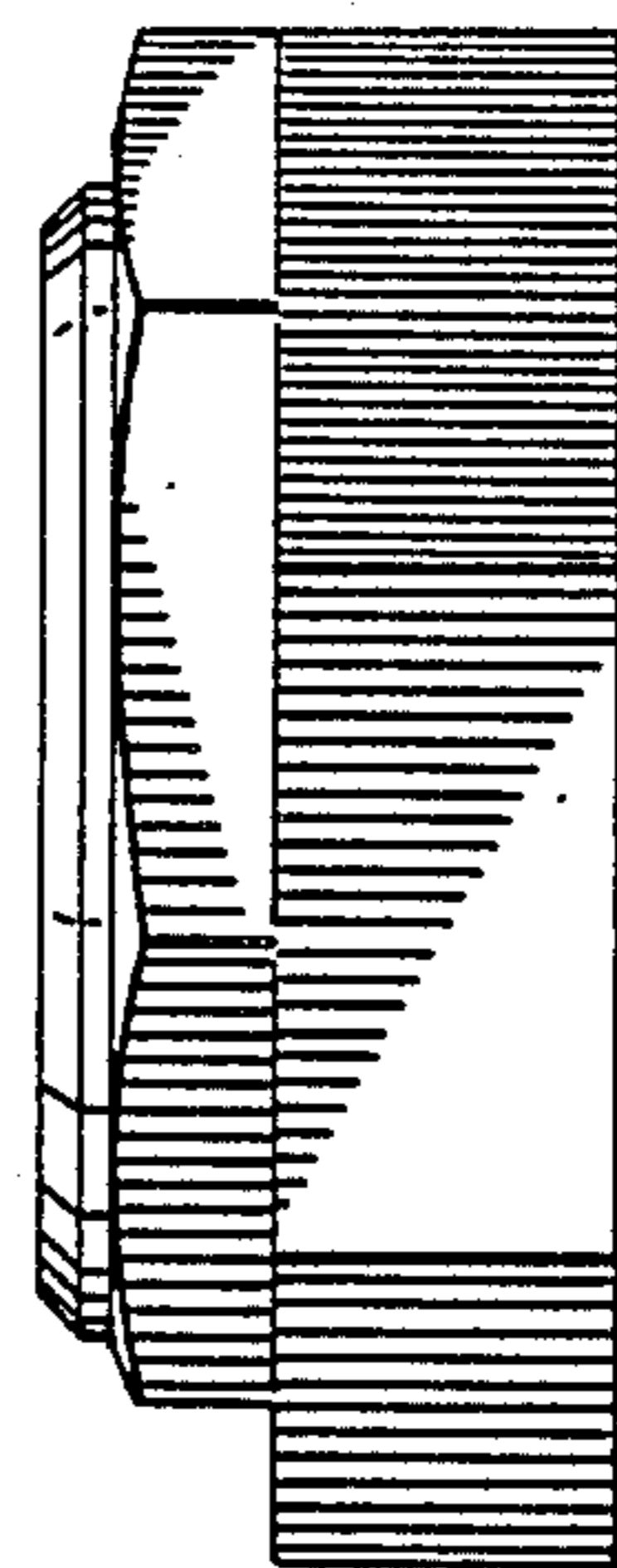

FIG. 2

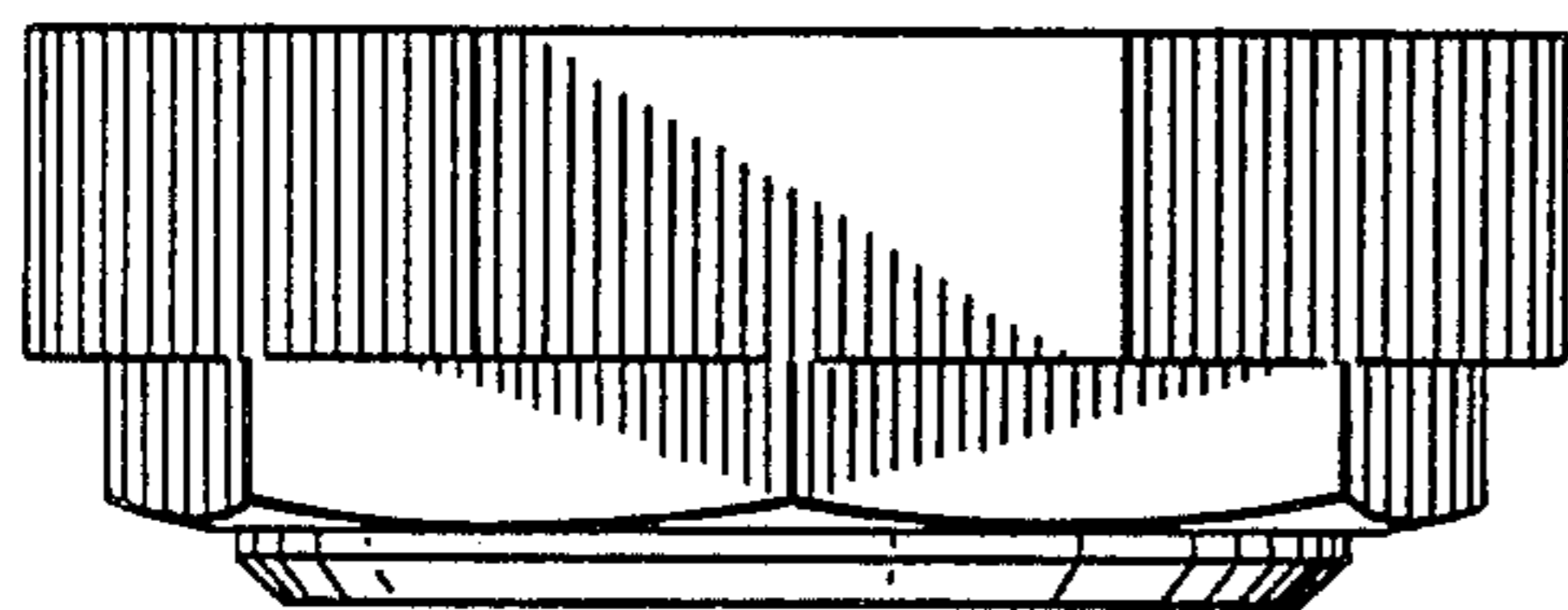

FIG. 3

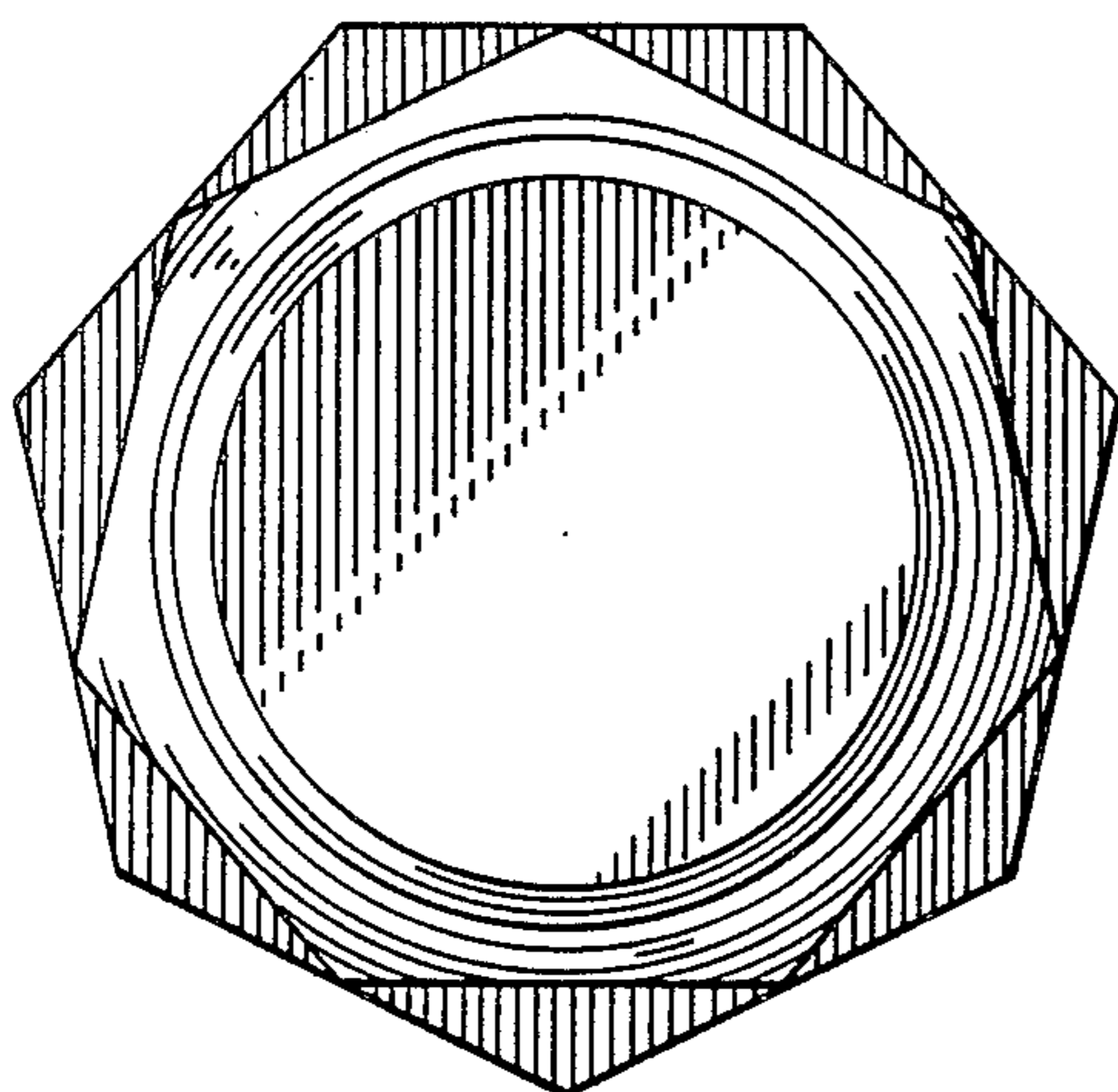

FIG. 4

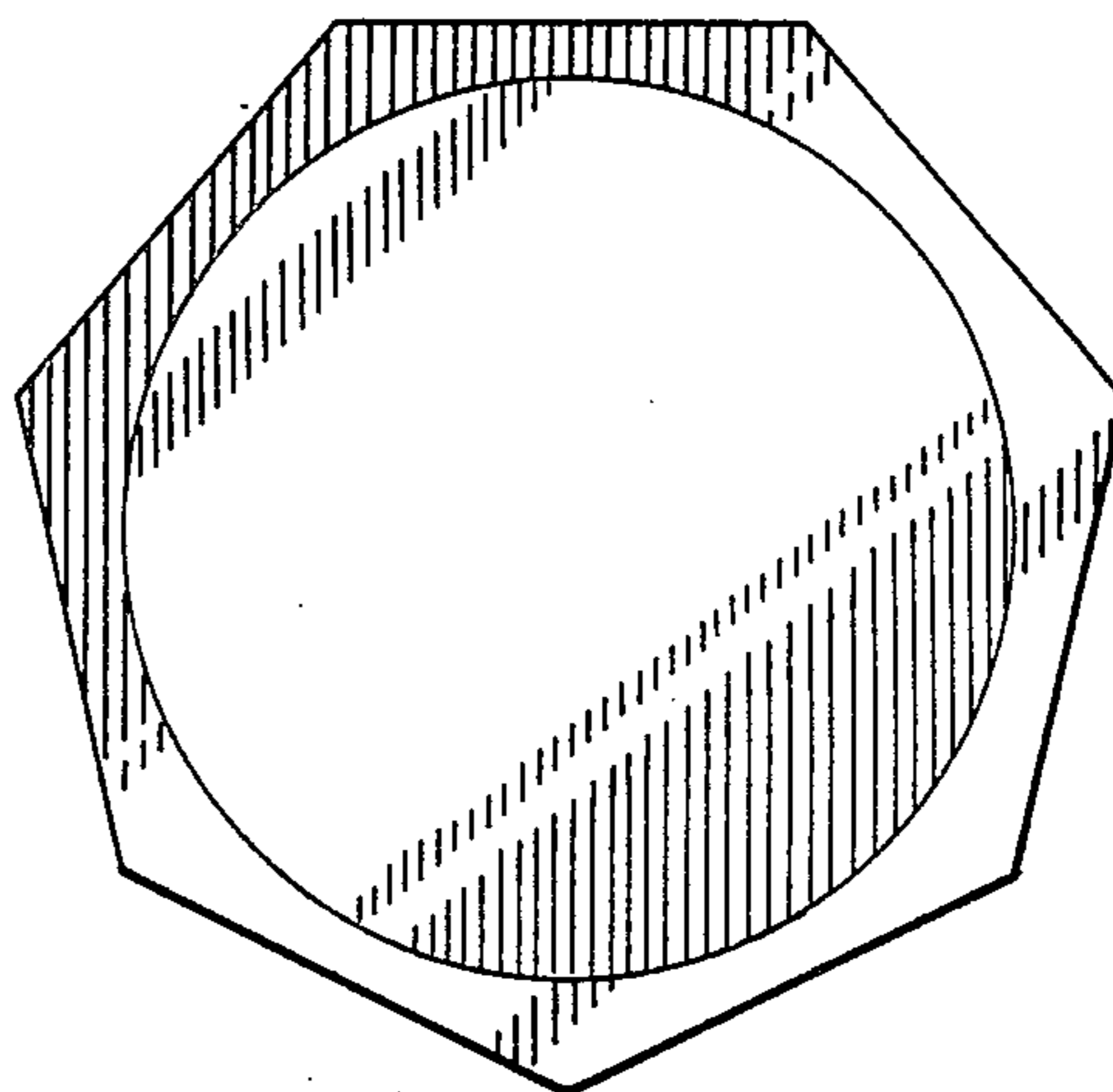

FIG. 5