

[54] AUTOMOBILE FRONT COMBINATION LAMP

[75] Inventor: Norihiko Kawaoka, Hiroshima, Japan

[73] Assignee: Mazda Motor Corporation, Hiroshima, Japan

[**] Term: 14 Years

[21] Appl. No.: 813,428

[22] Filed: Dec. 26, 1985

[52] U.S. Cl. D26/28

[58] Field of Search D26/28-36, D26/118, 120, 121, 122; 362/61, 80, 82, 83, 326-339

[56] References Cited

U.S. PATENT DOCUMENTS

- D. 285,258 8/1986 Hamasaki D26/28
- D. 287,289 12/1986 Kato et al. D26/28
- D. 287,290 12/1986 Kato et al. D26/28

FOREIGN PATENT DOCUMENTS

623523 4/1984 Japan .

OTHER PUBLICATIONS

Car Graphic, No. 10, 1985, p. 66.

Car Graphic, No. 11, 1985, p. 54.

Primary Examiner—Susan J. Lucas

Attorney, Agent, or Firm—Fleit, Jacobson, Cohn & Price

[57] CLAIM

The ornamental design for an automobile front combination lamp, as shown and described.

DESCRIPTION

FIG. 1 is a perspective view of the automobile front combination lamp showing my new design;
 FIG. 2 is a front elevational view thereof;
 FIG. 3 is a rear elevational view thereof;
 FIG. 4 is a top plan view thereof;
 FIG. 5 is a bottom plan view thereof;
 FIG. 6 is a right side elevational view thereof;
 FIG. 7 is a left side elevational view thereof.

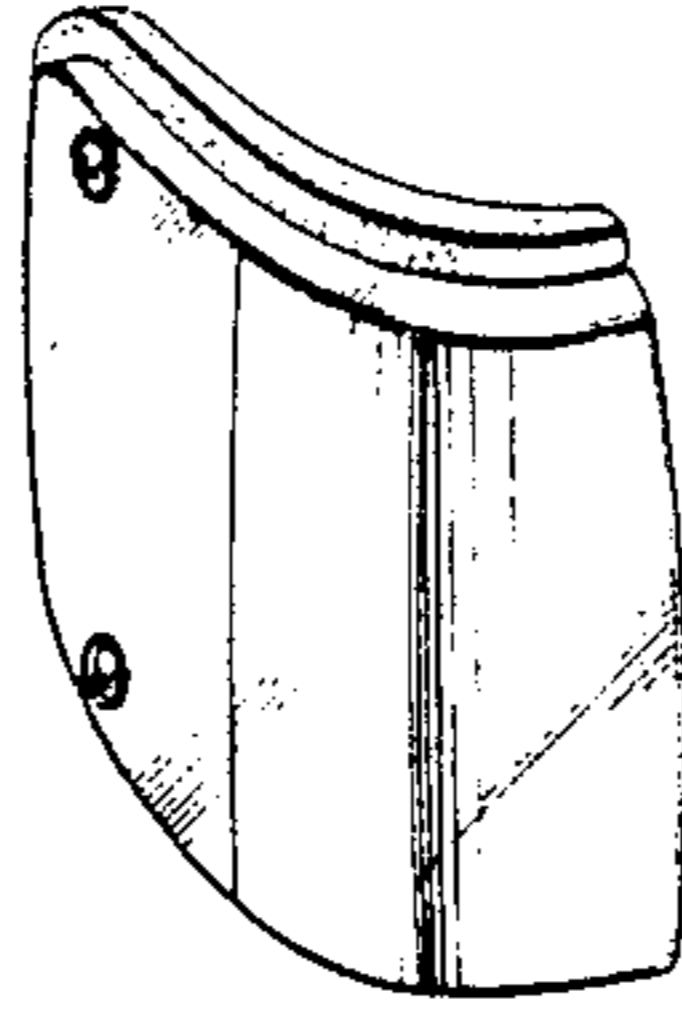

FIG. 1

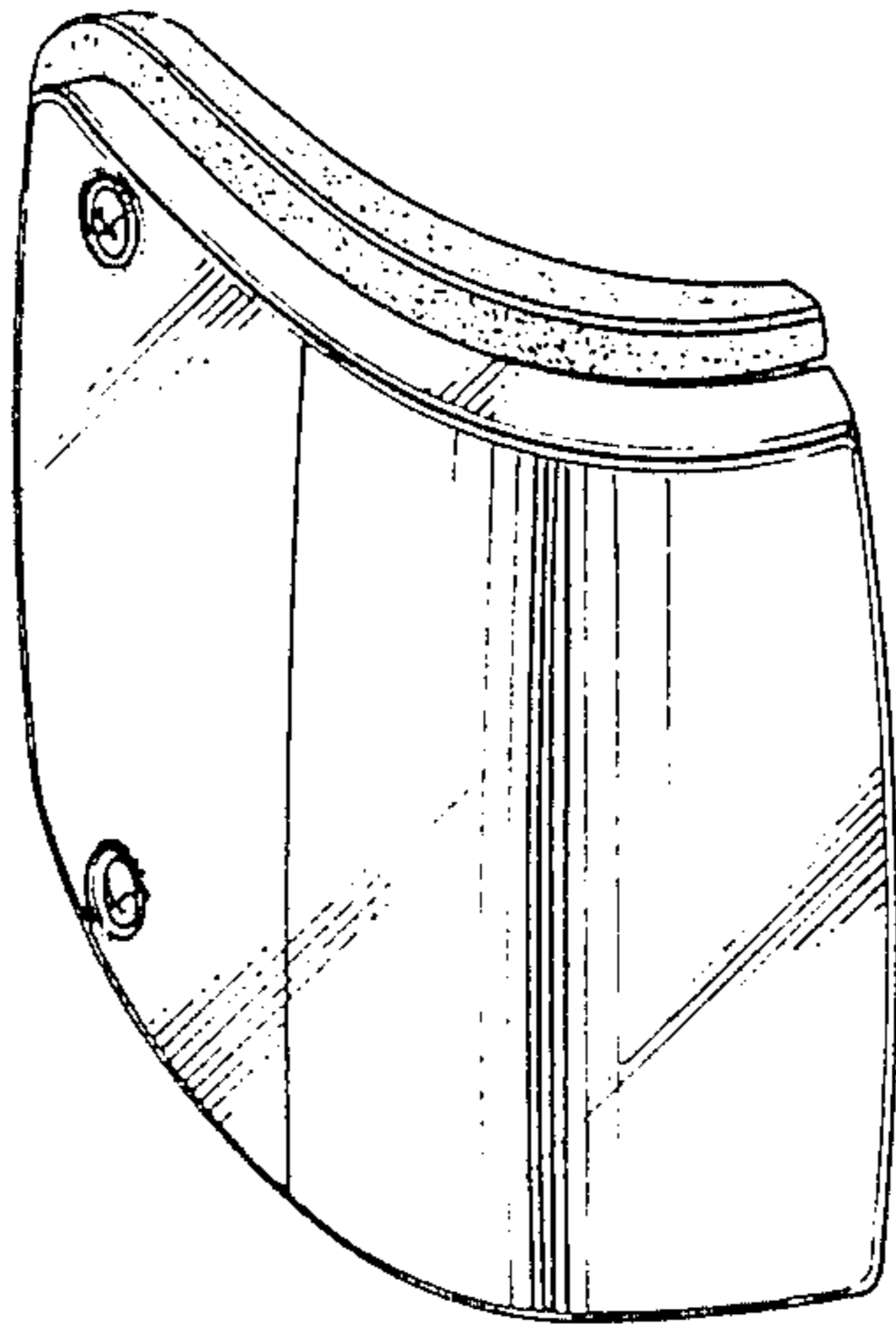

FIG. 2

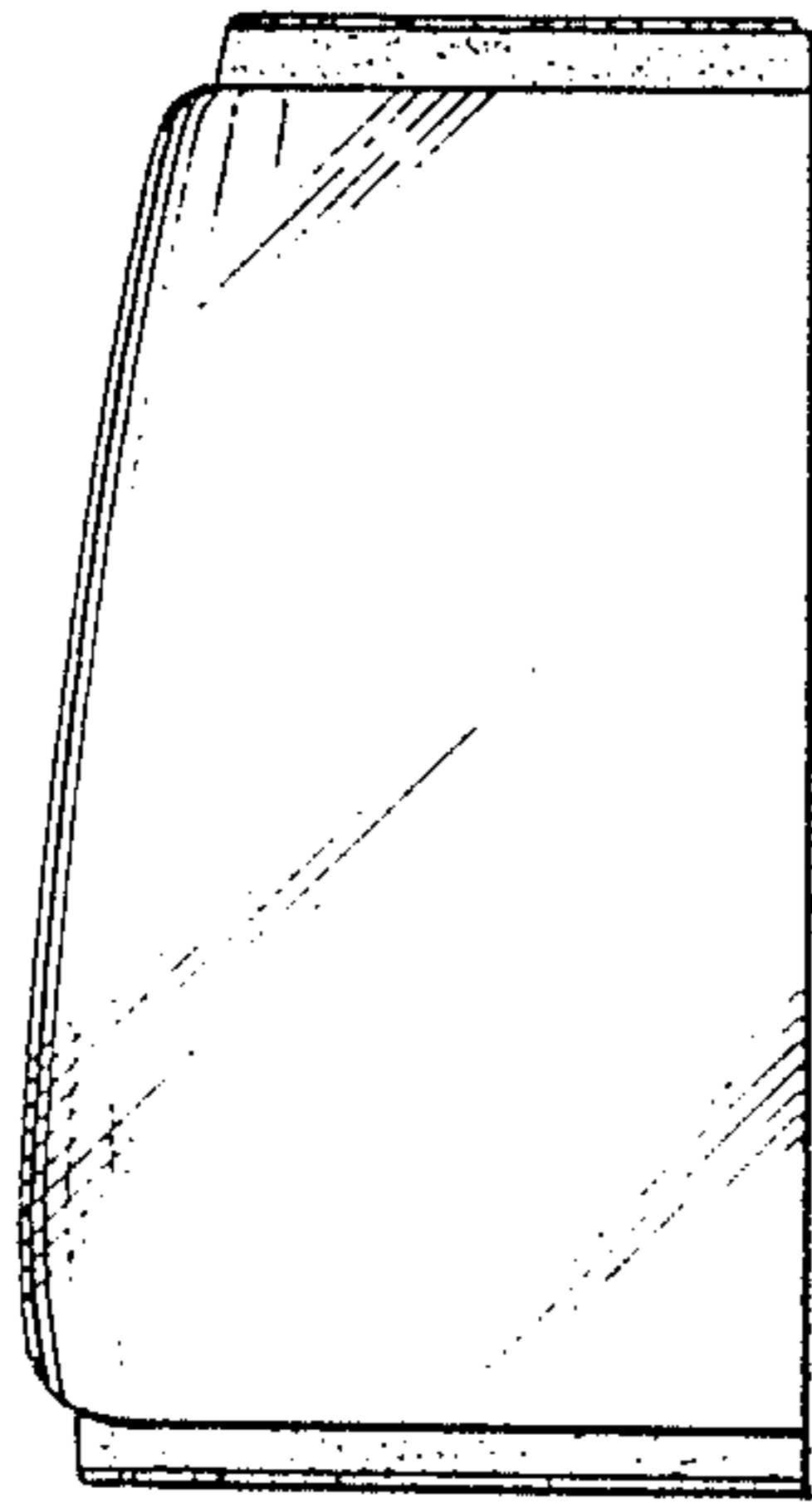

FIG. 3

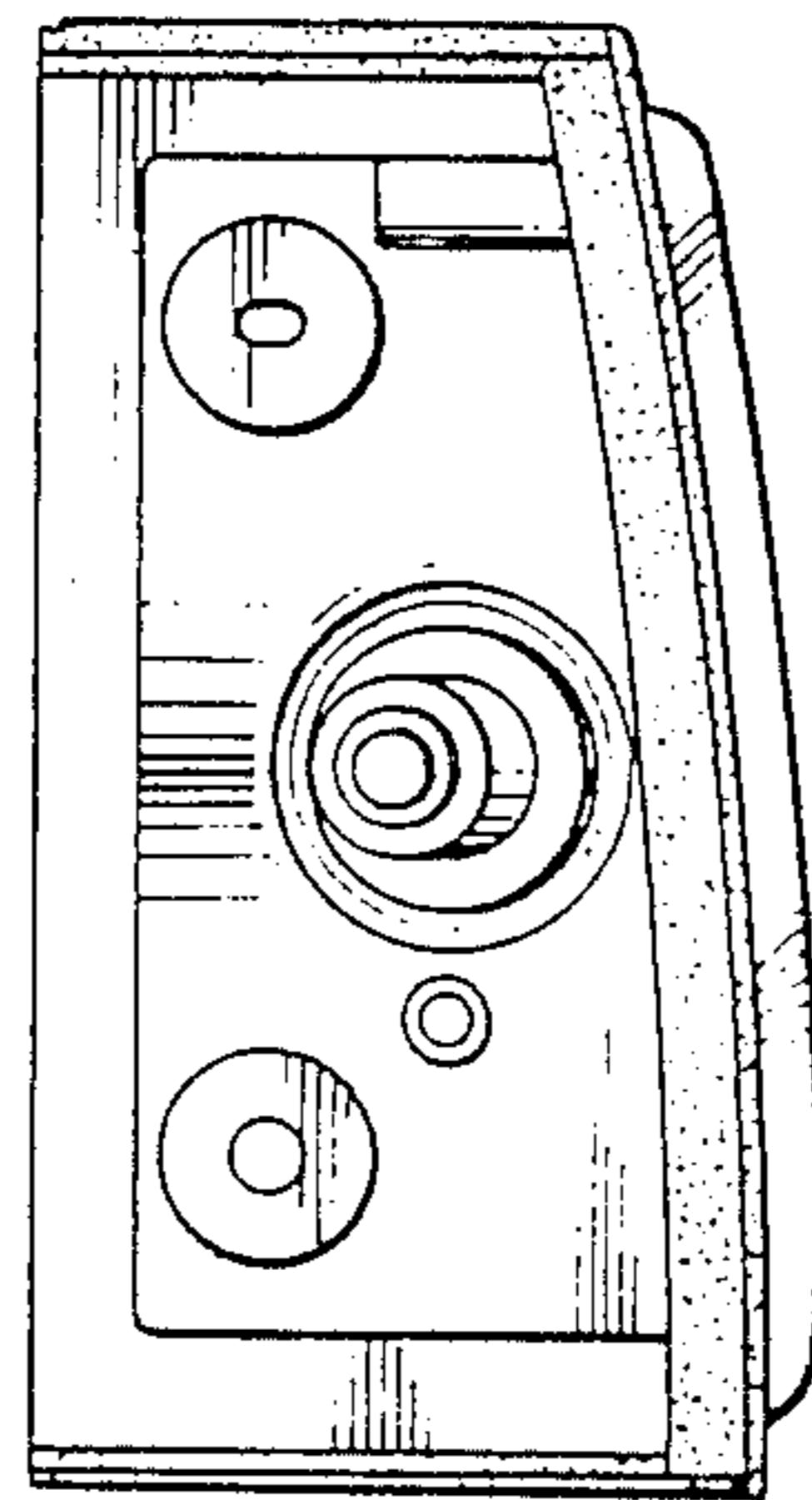

FIG. 4

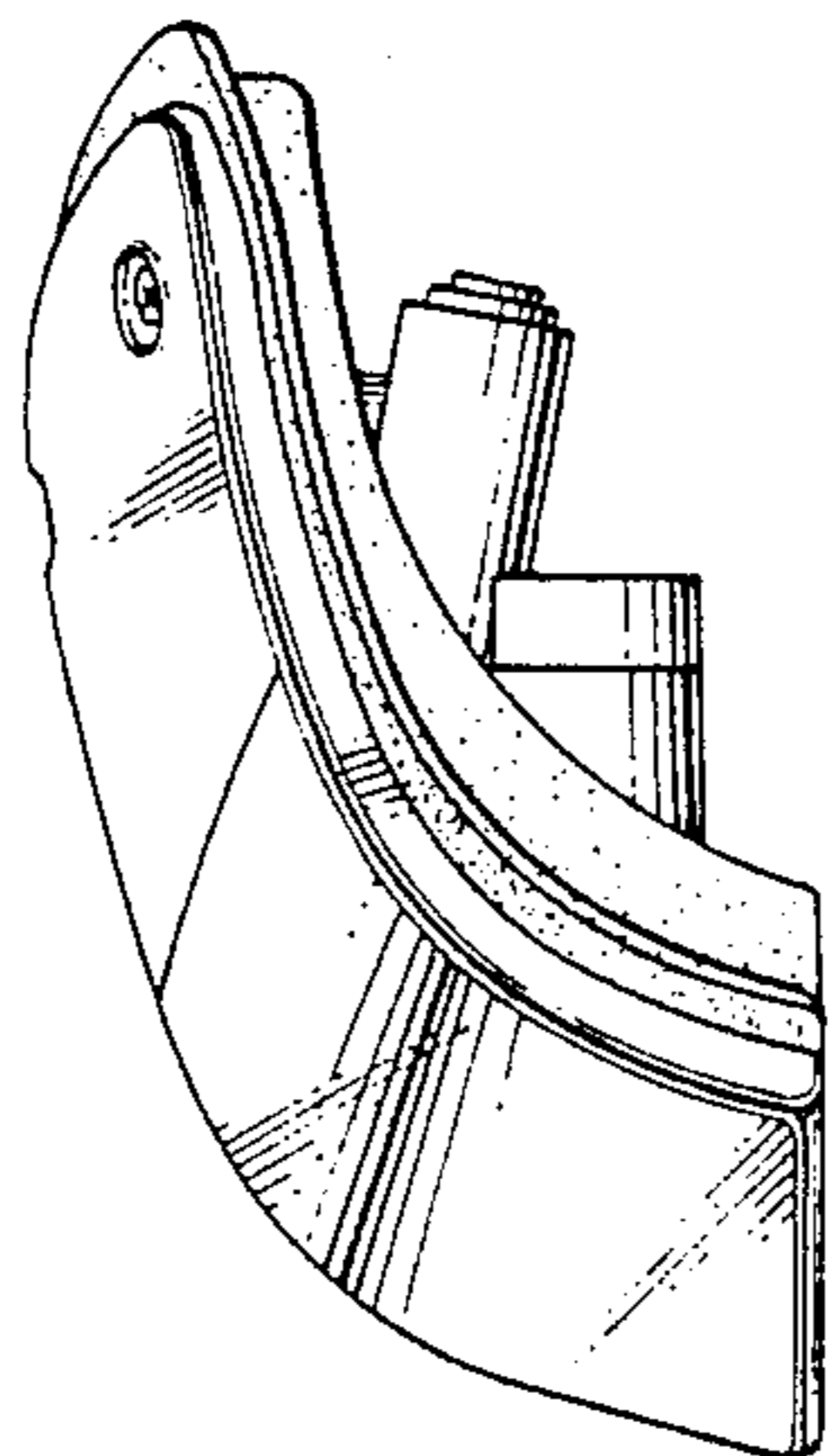

FIG. 5

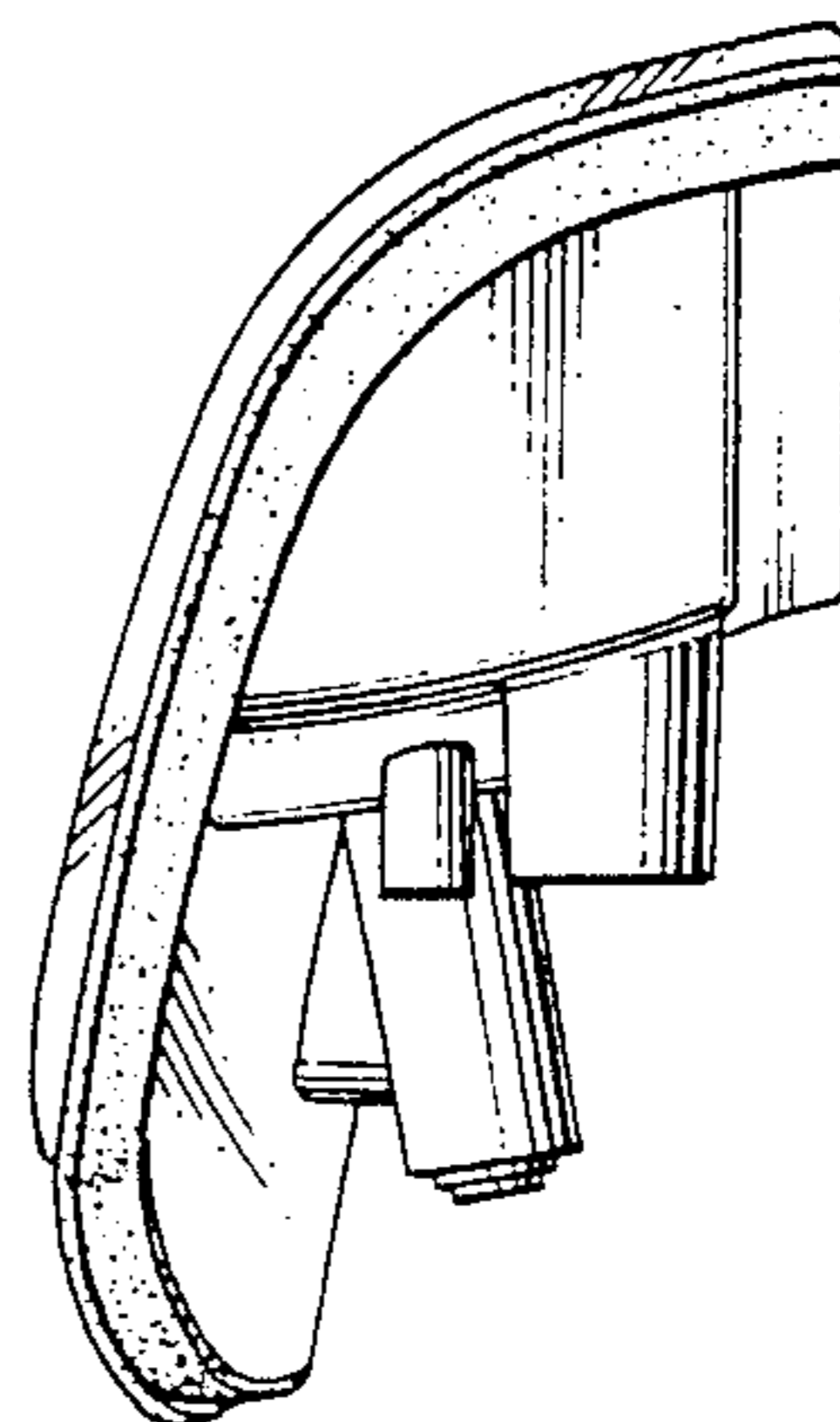

FIG. 6

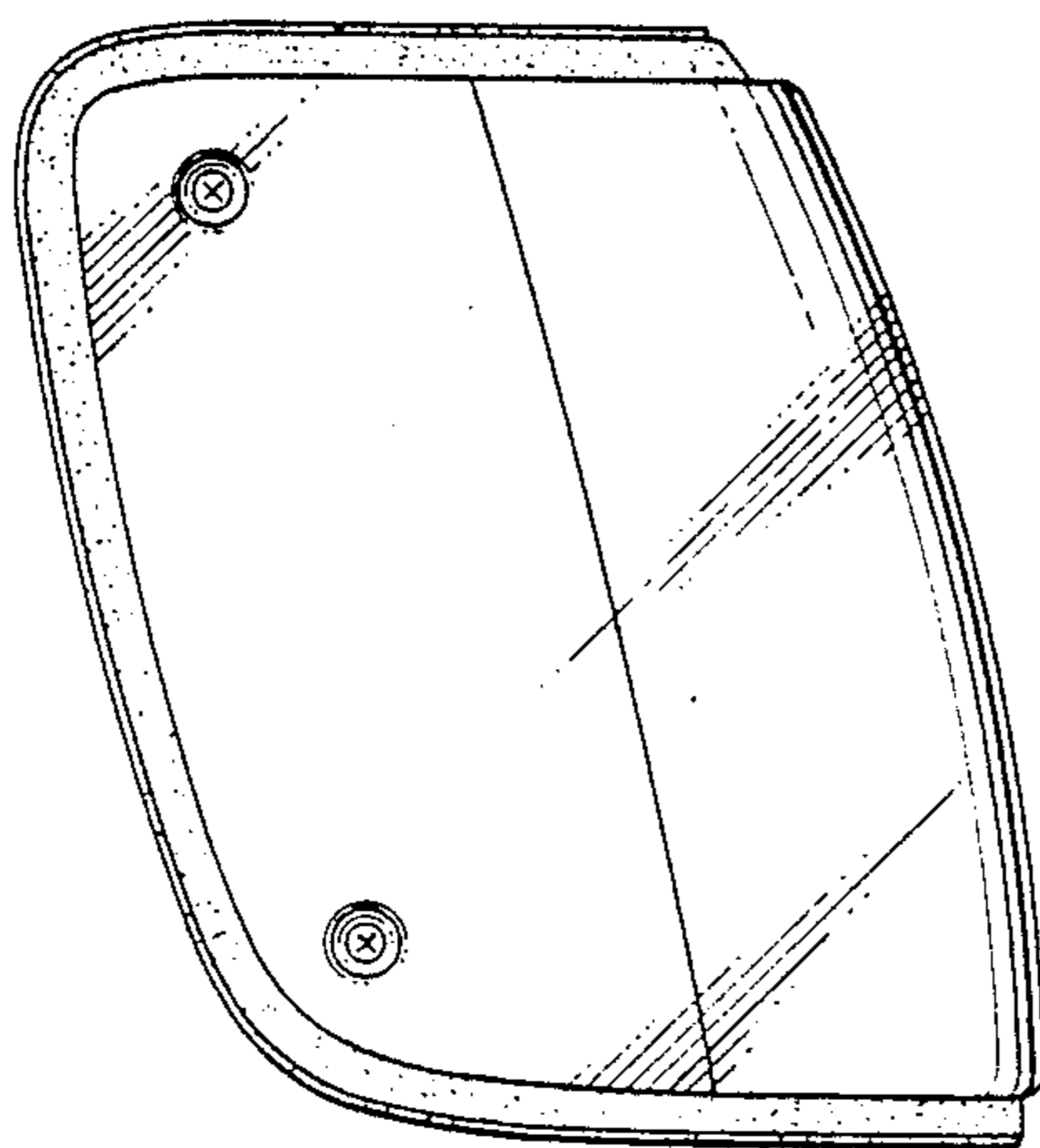

FIG. 7

