

[54] RECONFIGURABLE TOY VEHICLE

[75] Inventor: Hideaki Yoke, Tokyo, Japan

[73] Assignee: Takara Co., Ltd., Tokyo, Japan

[\*\*] Term: 14 Years

[21] Appl. No.: 817,828

[22] Filed: Jan. 10, 1986

[30] Foreign Application Priority Data

Oct. 4, 1985 [JP] Japan ..... 60-41663

[52] U.S. Cl. .... D21/136; D21/150

[58] Field of Search ..... D21/128-140,  
D21/150, 166; 446/71, 72, 73, 74, 75, 77, 78,  
576, 378, 383, 381; D12/70

[56] References Cited

U.S. PATENT DOCUMENTS

D. 279,592	7/1985	Ogawa	.....	D21/150
D. 284,490	7/1986	Ohno	.....	D21/150
D. 285,466	9/1986	Ohno	.....	D21/150
D. 290,723	7/1987	Kitamura	.....	D21/150
D. 292,425	10/1987	Lim	.....	D21/150

Primary Examiner—Charles A. Rademaker  
Attorney, Agent, or Firm—Price, Gess & Ubell

[57] CLAIM

The ornamental design for a reconfigurable toy vehicle, substantially as shown and described.

DESCRIPTION

FIG. 1 is a front perspective view of a reconfigurable toy vehicle, showing my new design;  
 FIG. 2 is a front elevational view thereof;  
 FIG. 3 is a right side elevational view thereof, the side opposite being substantially a mirror image;  
 FIG. 4 is a rear elevational view thereof;  
 FIG. 5 is a top plan view thereof;  
 FIG. 6 is a bottom plan view thereof;  
 FIG. 7 is a front perspective view of the design shown in FIGS. 1 through 6 reconfigured in a toy robotic humanoid configuration;  
 FIG. 8 is a front elevational view thereof;  
 FIG. 9 is a right side elevational view thereof, the side opposite being substantially a mirror image;  
 FIG. 10 is a rear elevational view thereof;  
 FIG. 11 is a top plan view thereof; and  
 FIG. 12 is a bottom plan view thereof.

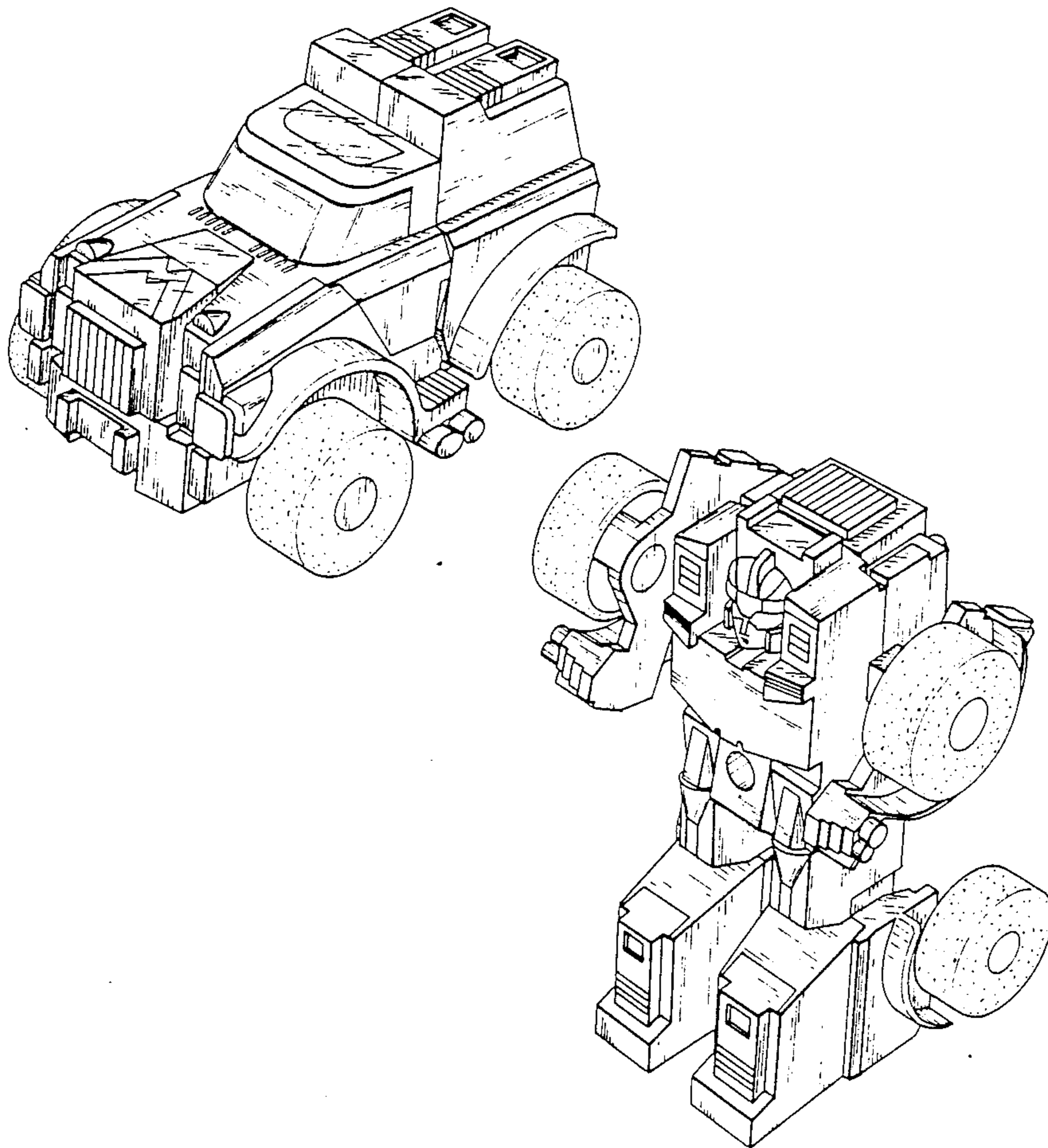

FIG. 2

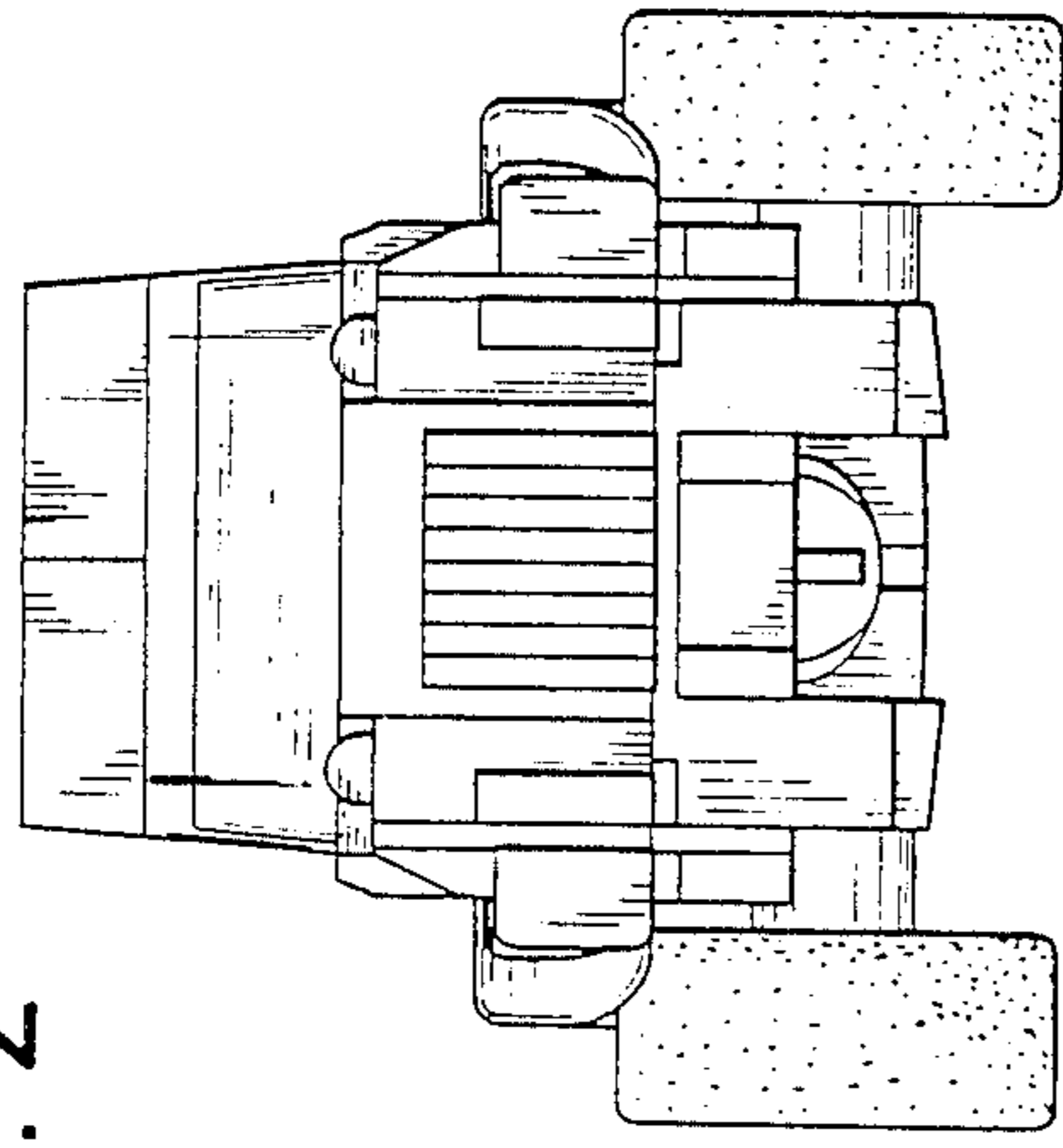

FIG. 3

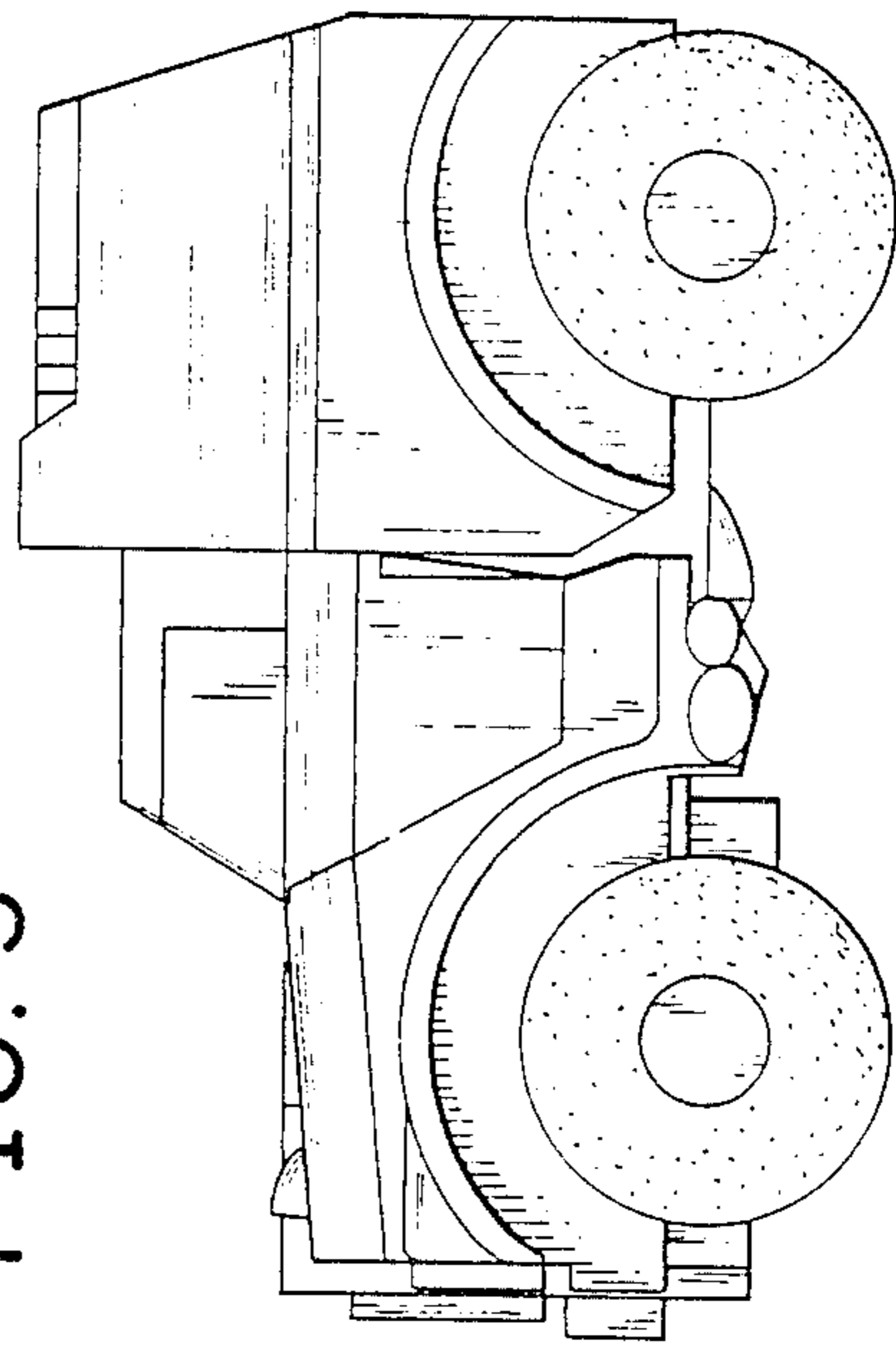

FIG. 1

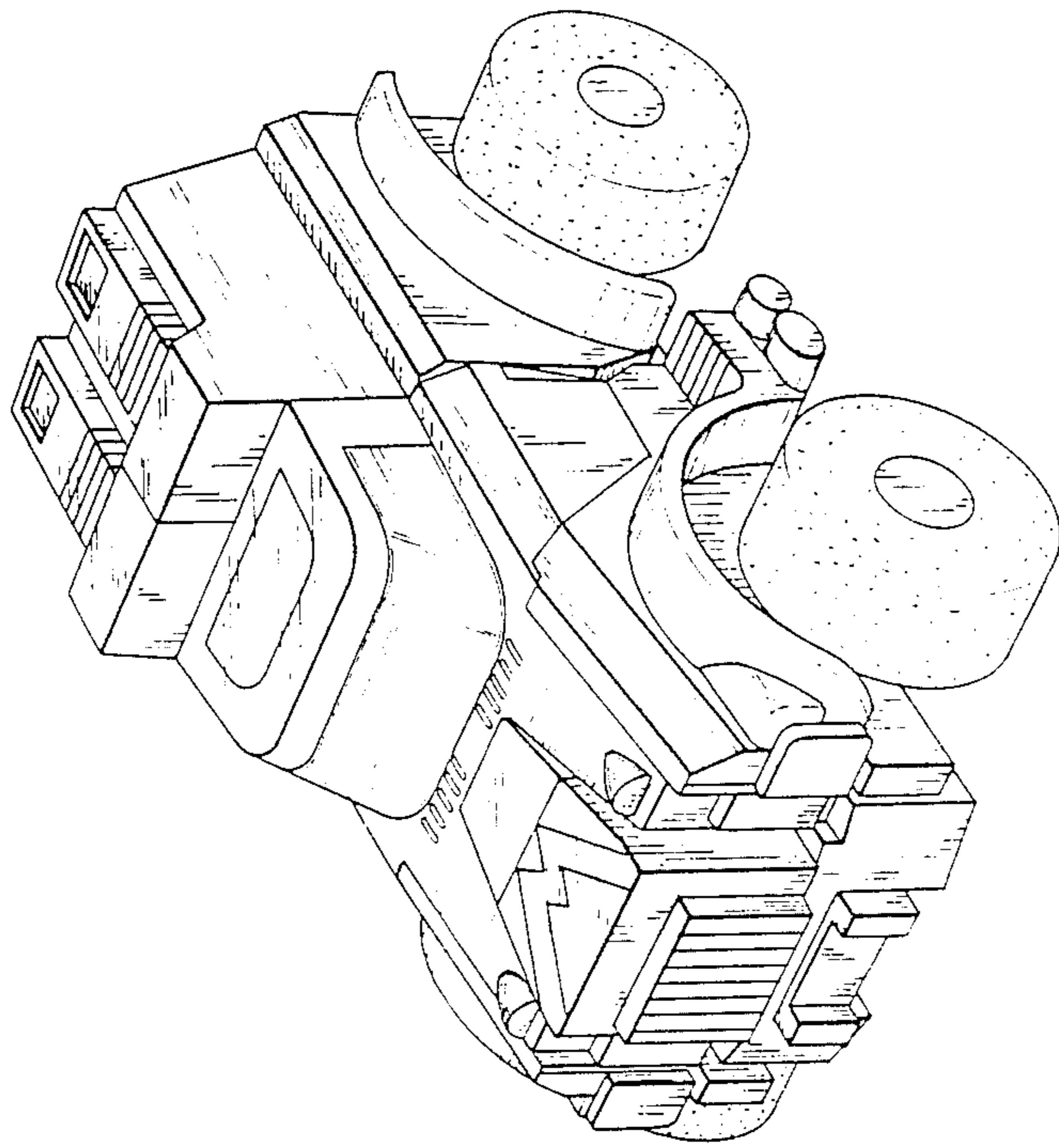

FIG. 4

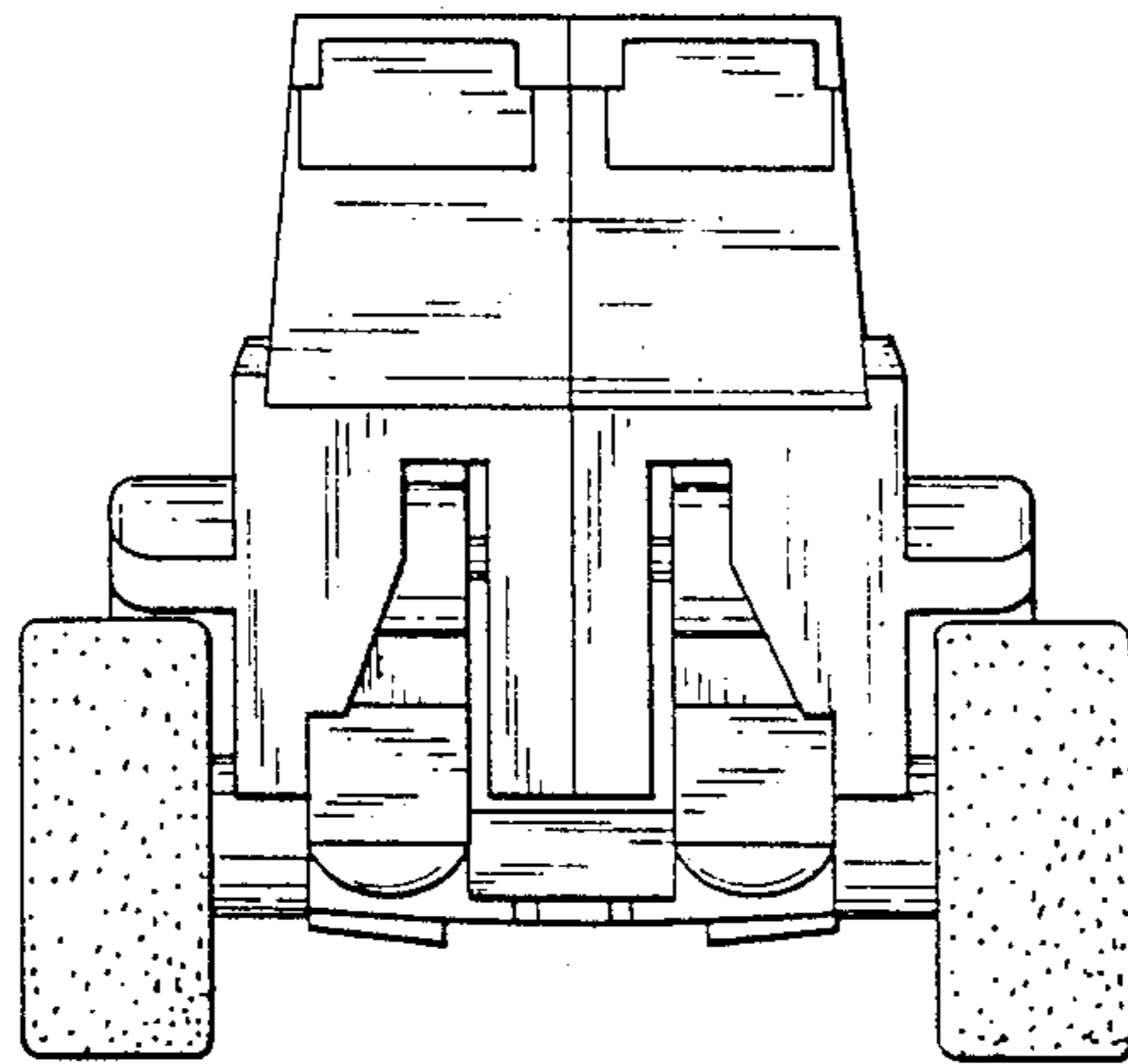

FIG. 5

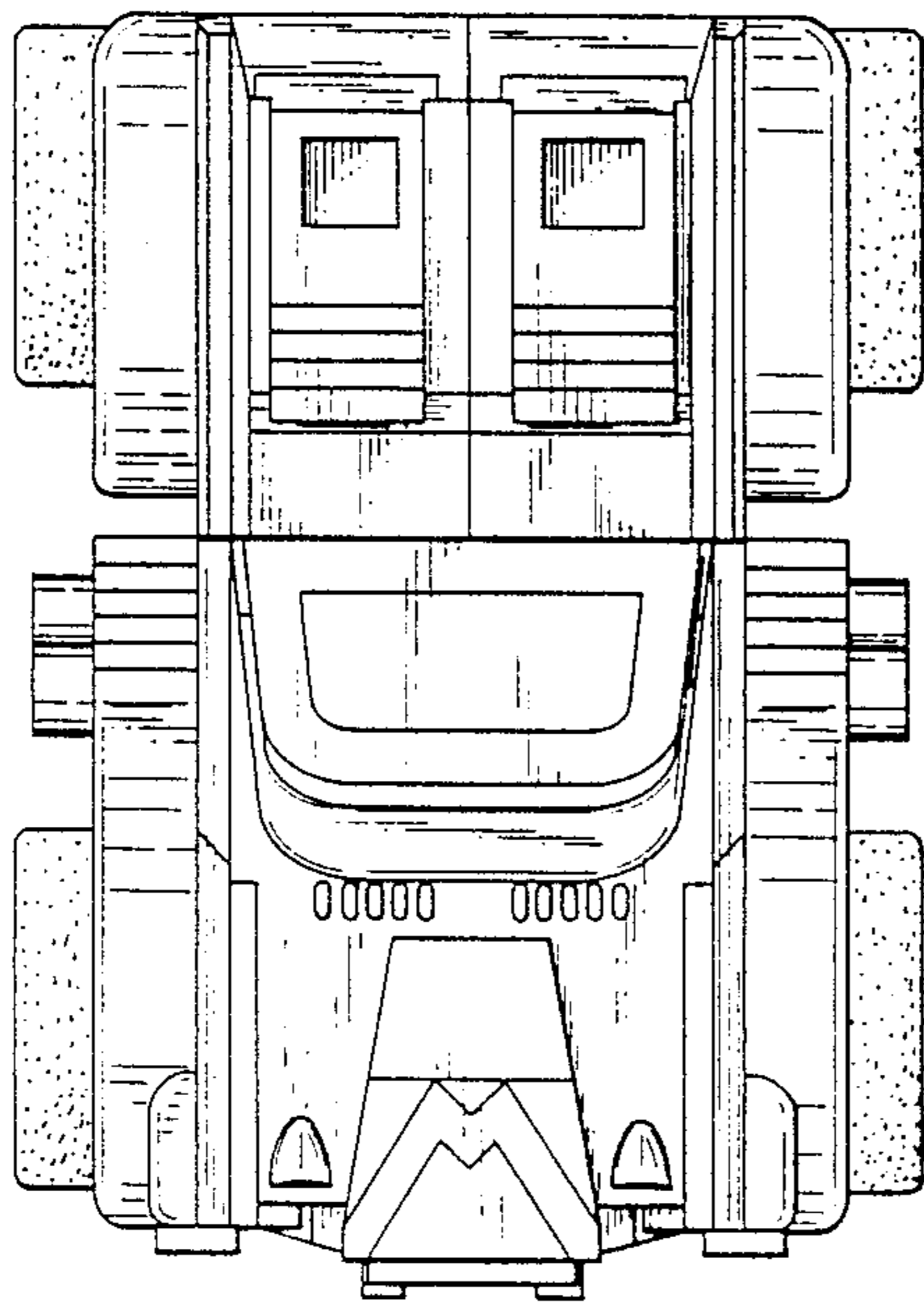

FIG. 6

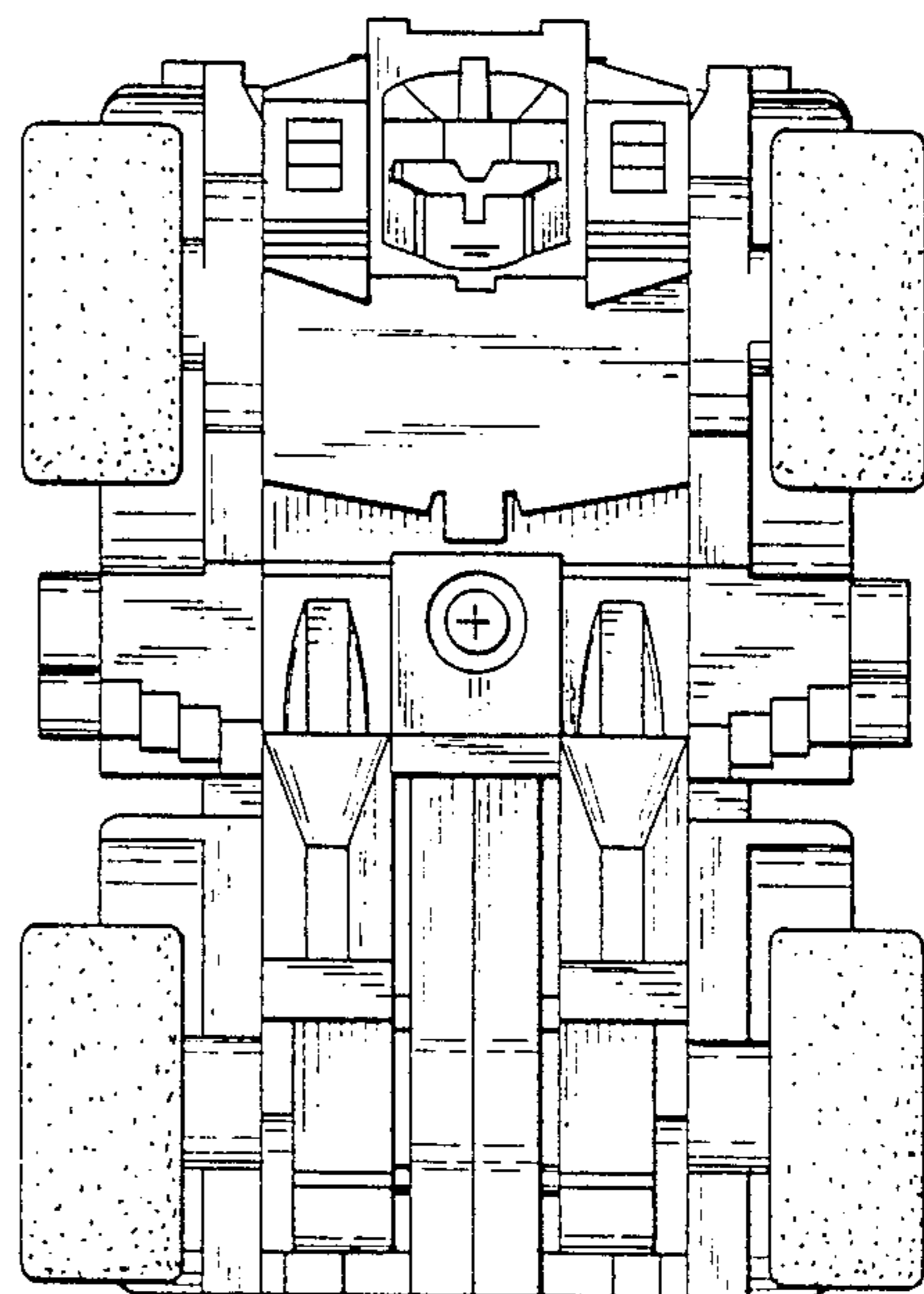



FIG. 8

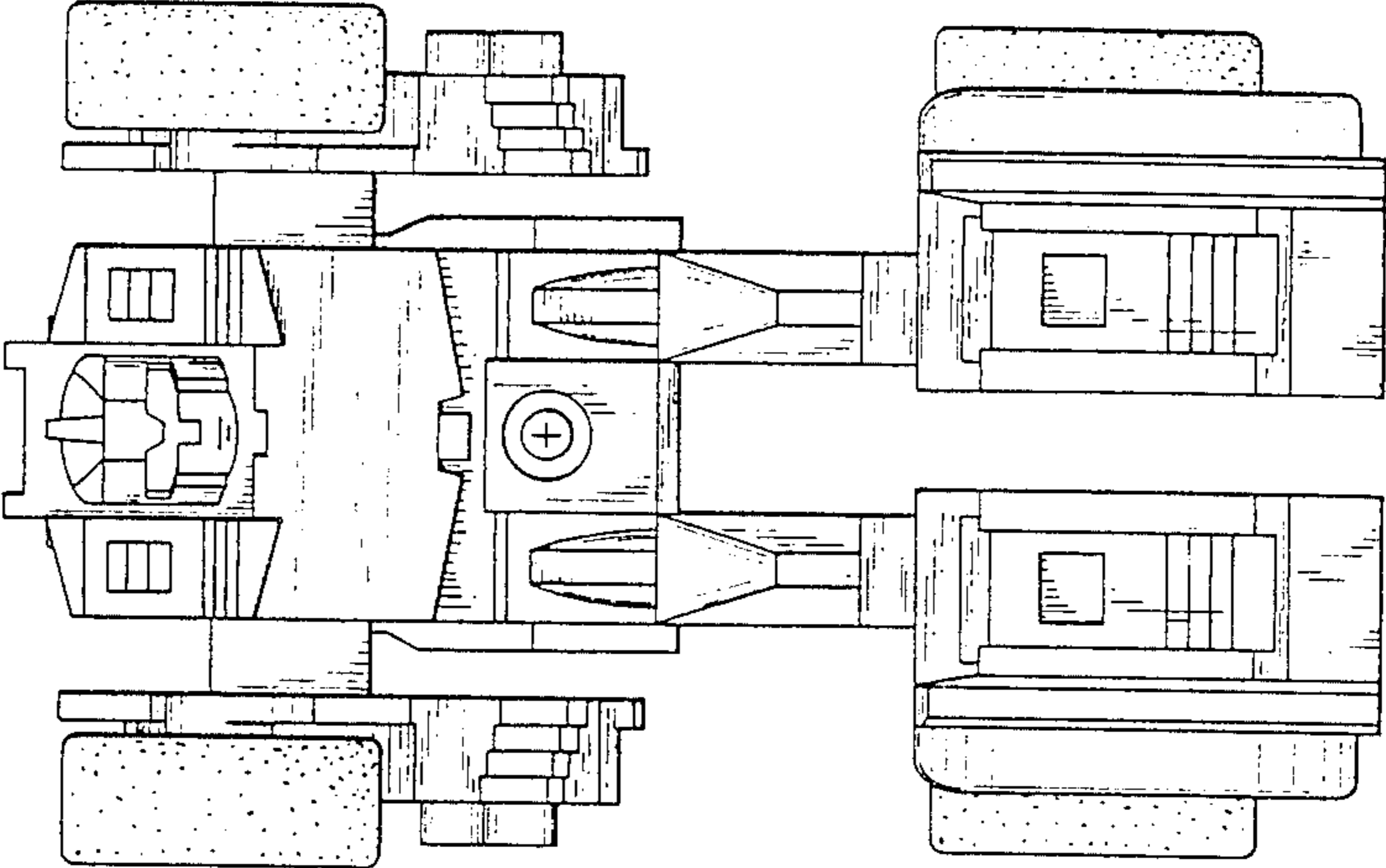

FIG. 7

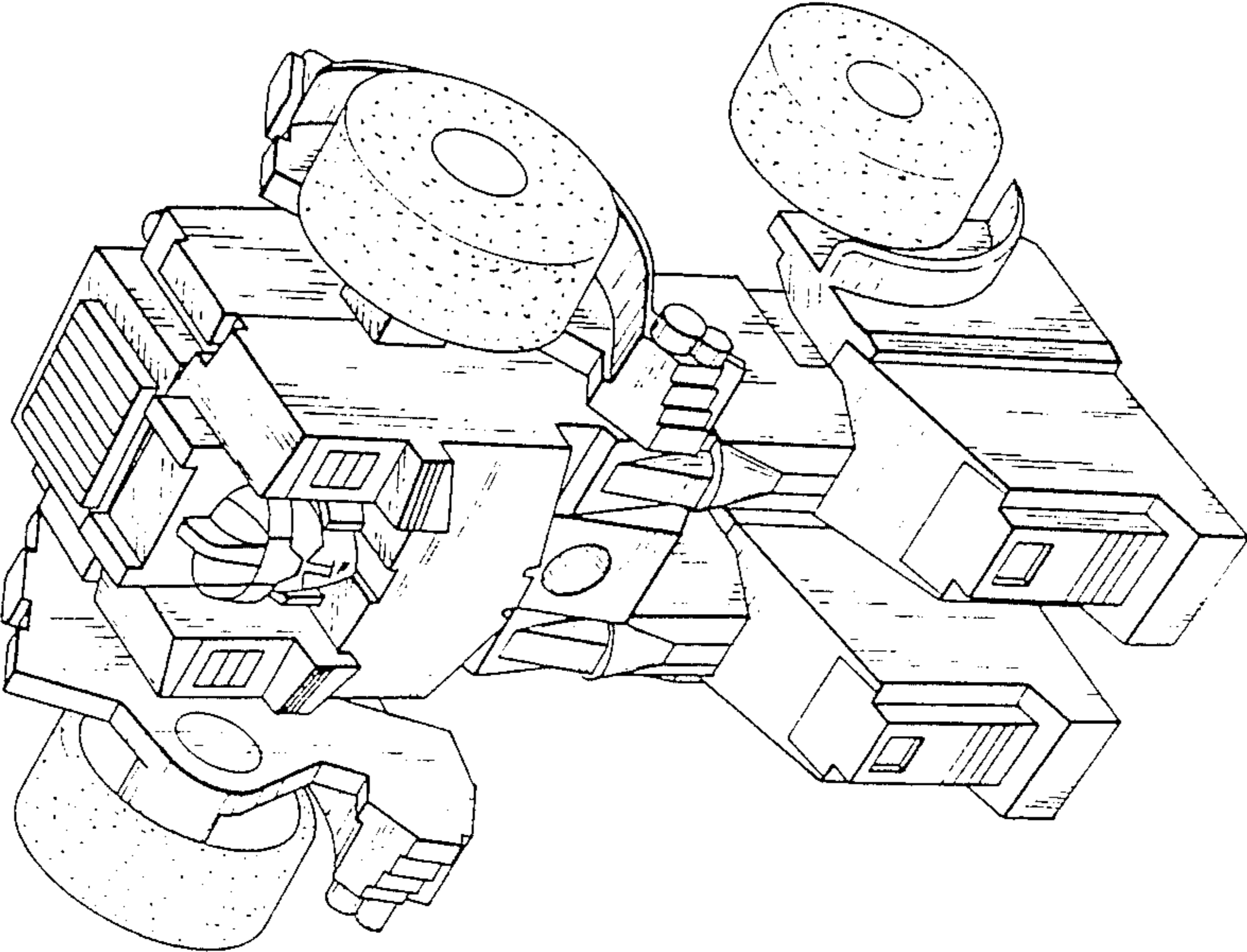

FIG.10

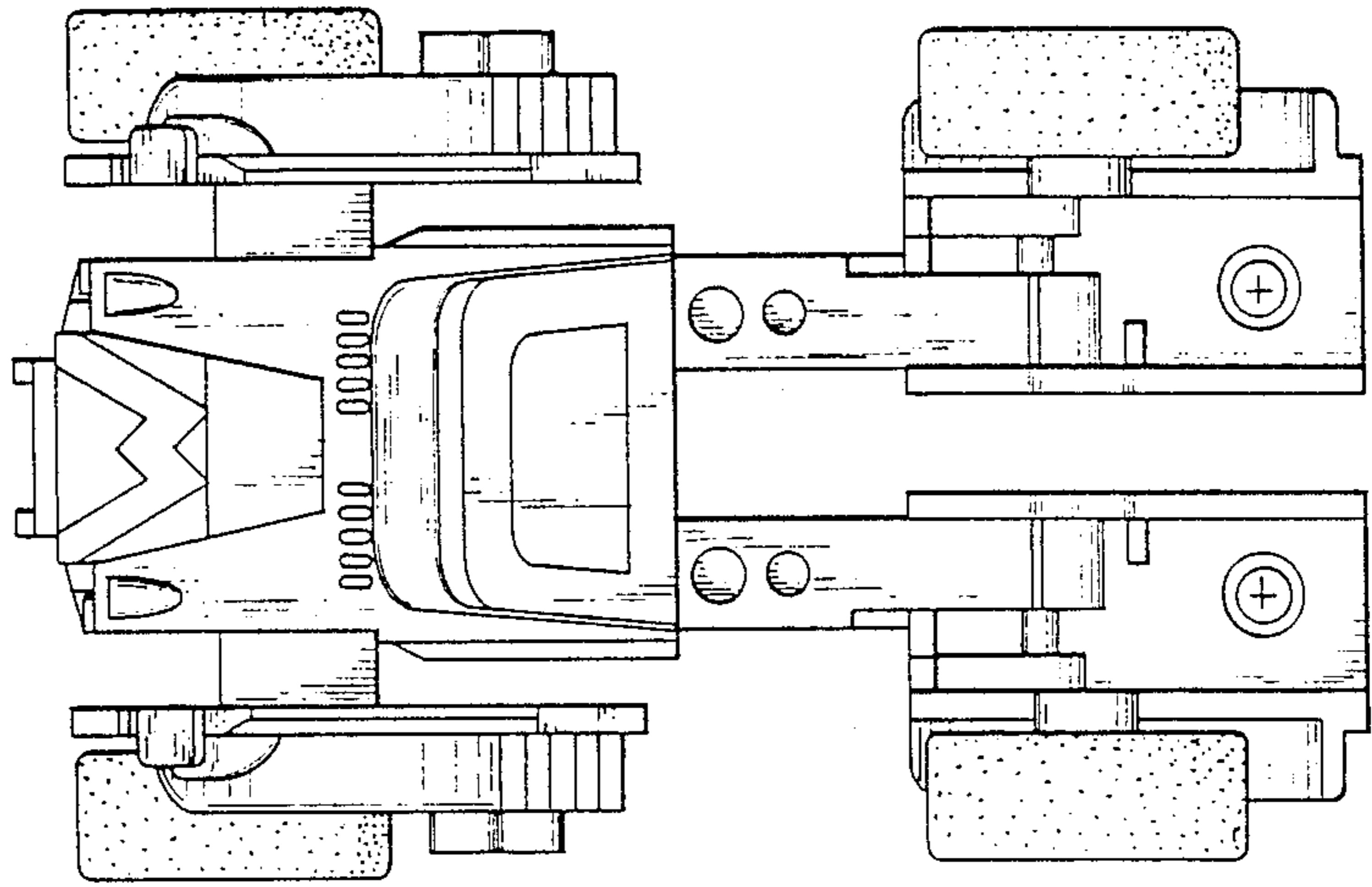

FIG. 9

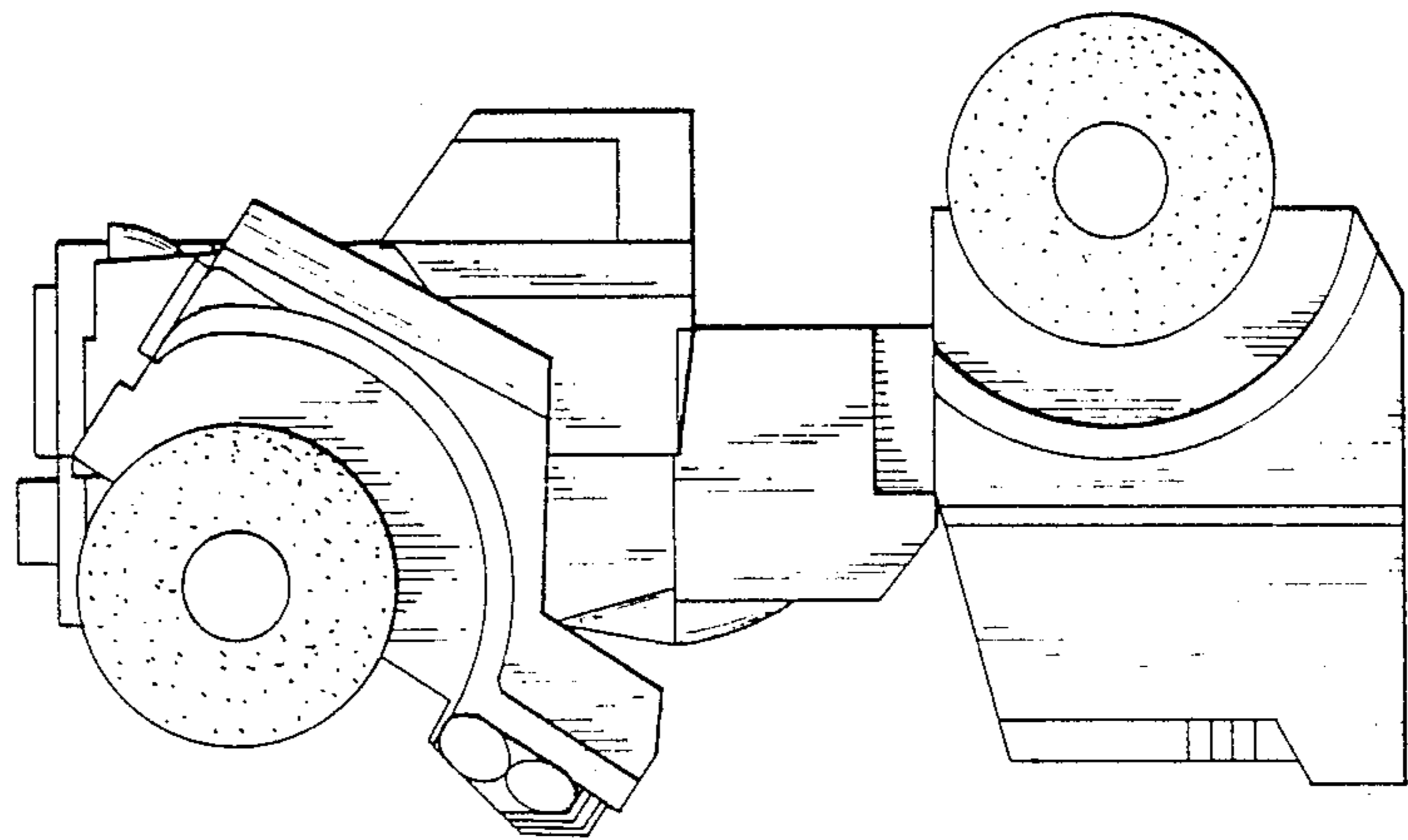

FIG.12

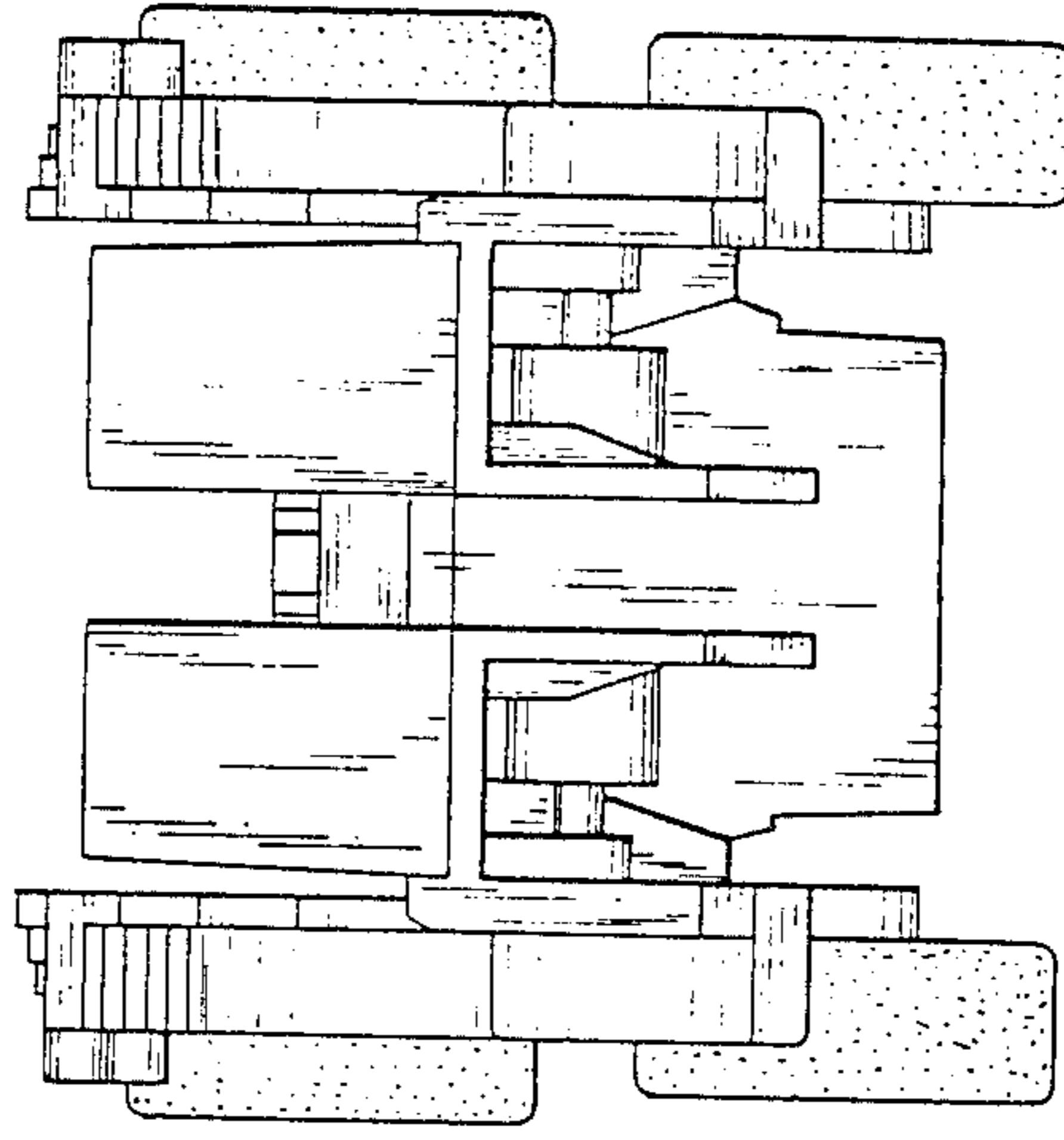

FIG.11

