

[54] RECONFIGURABLE TOY VEHICLE

[75] Inventor: Daishirou Shibukawa, Tokyo, Japan

[73] Assignee: Takara Co., Ltd., Tokyo, Japan

[\*\*] Term: 14 Years

[21] Appl. No.: 835,317

[22] Filed: Feb. 24, 1986

[30] Foreign Application Priority Data

Dec. 24, 1985 [JP] Japan ..... 60-53625

[52] U.S. Cl. .... D21/136; D21/90; D21/150; D21/166

[58] Field of Search ..... D21/128, 136, 150, 166, D21/137, 90, 85, 87; D12/327; 446/71, 72, 80, 487, 76, 77

[56] References Cited

U.S. PATENT DOCUMENTS

- D. 279,592 7/1985 Ogawa ..... D21/150
- D. 287,518 12/1986 Ohno ..... D21/150
- 4,594,071 6/1986 Zaruba et al. .... 446/487

Primary Examiner—Charles A. Rademaker  
Attorney, Agent, or Firm—Price, Gess & Ubell

[57] CLAIM

The ornamental design for a reconfigurable toy vehicle, substantially as shown and described.

DESCRIPTION

FIG. 1 is a front side perspective view of a reconfigurable toy vehicle showing my new design;  
 FIG. 2 is a front elevational view thereof;  
 FIG. 3 is a right side elevational view thereof;  
 FIG. 4 is a left side elevational view thereof;  
 FIG. 5 is a rear elevational view thereof;  
 FIG. 6 is a top plan view thereof;  
 FIG. 7 is a bottom plan view thereof;  
 FIG. 8 is a front perspective view of the design shown in FIGS. 1 through 7 reconfigured into a toy helicopter configuration;  
 FIG. 9 is a front elevational view thereof;  
 FIG. 10 is a right side elevational view thereof;  
 FIG. 11 is a left side elevational view thereof;  
 FIG. 12 is a rear elevational view thereof;  
 FIG. 13 is a top plan view thereof;  
 FIG. 14 is a bottom plan view thereof;  
 FIG. 15 is another front perspective view of the design shown in FIGS. 1 through 7 reconfigured into a humanoid robot configuration;  
 FIG. 16 is a front elevational view thereof;  
 FIG. 17 is a right side elevational view thereof;  
 FIG. 18 is a left side elevational view thereof;  
 FIG. 19 is a rear elevational view thereof;  
 FIG. 20 is a top plan view thereof;  
 FIG. 21 is a bottom plan view thereof;

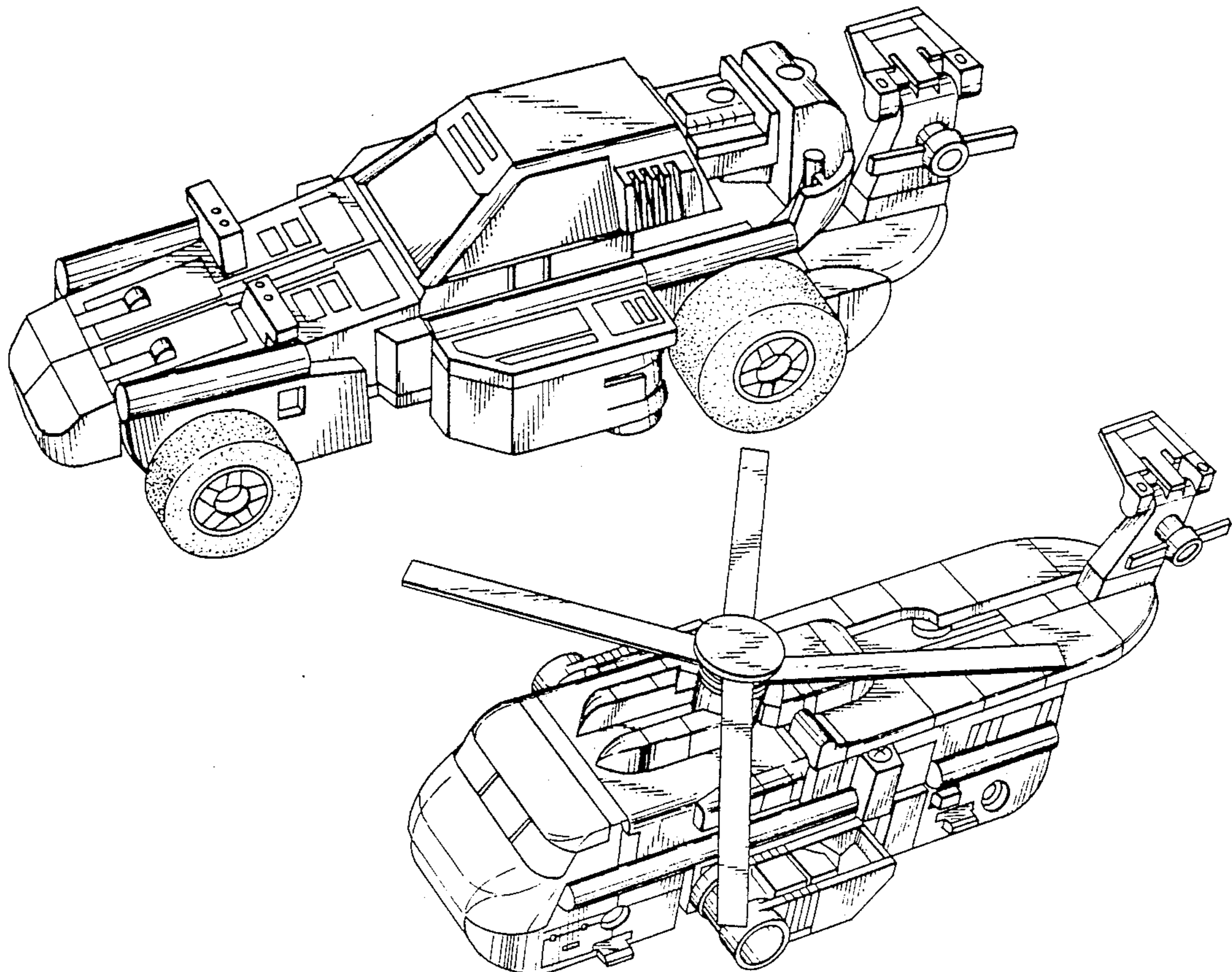

FIG. 1

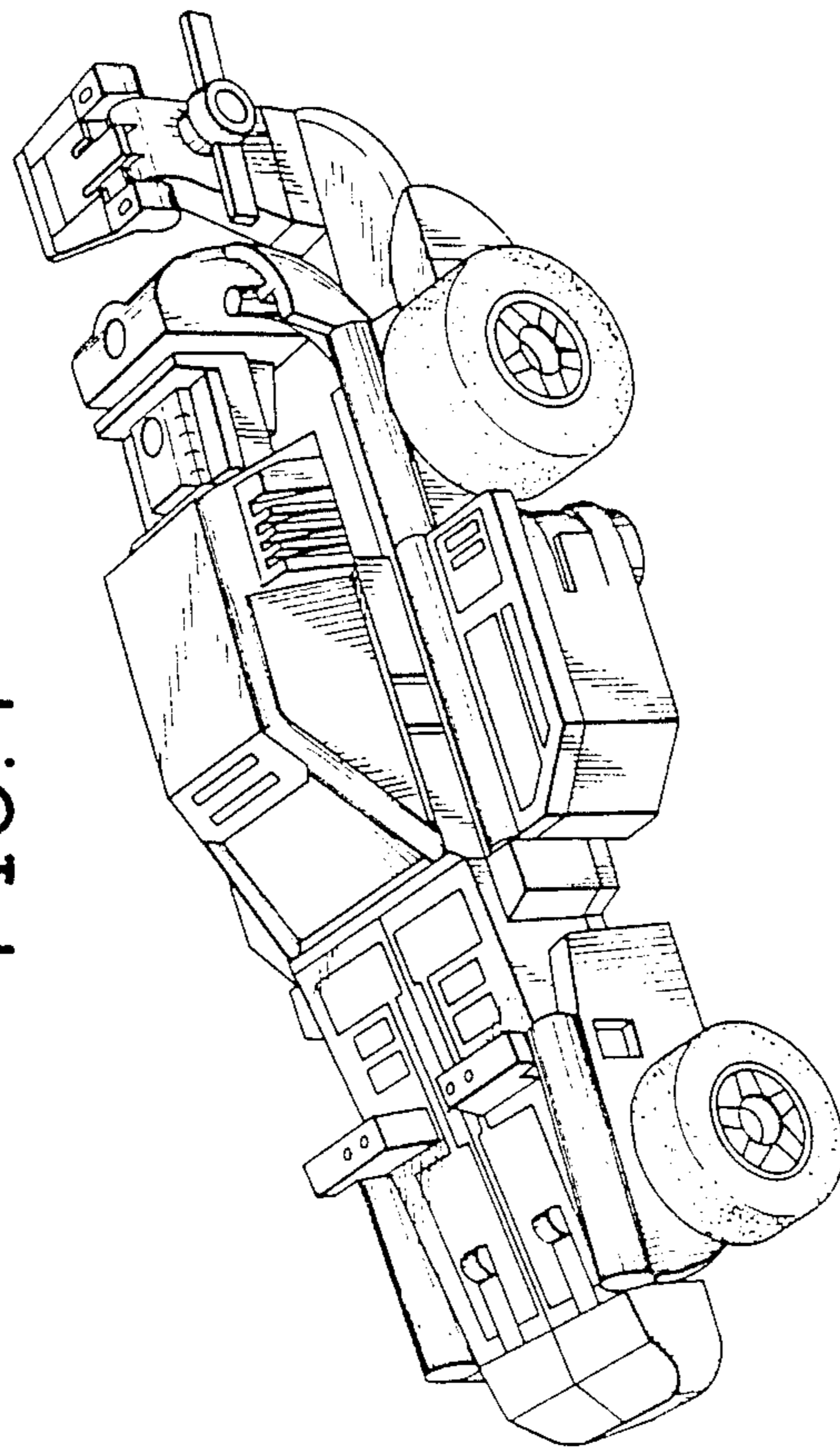

FIG. 2

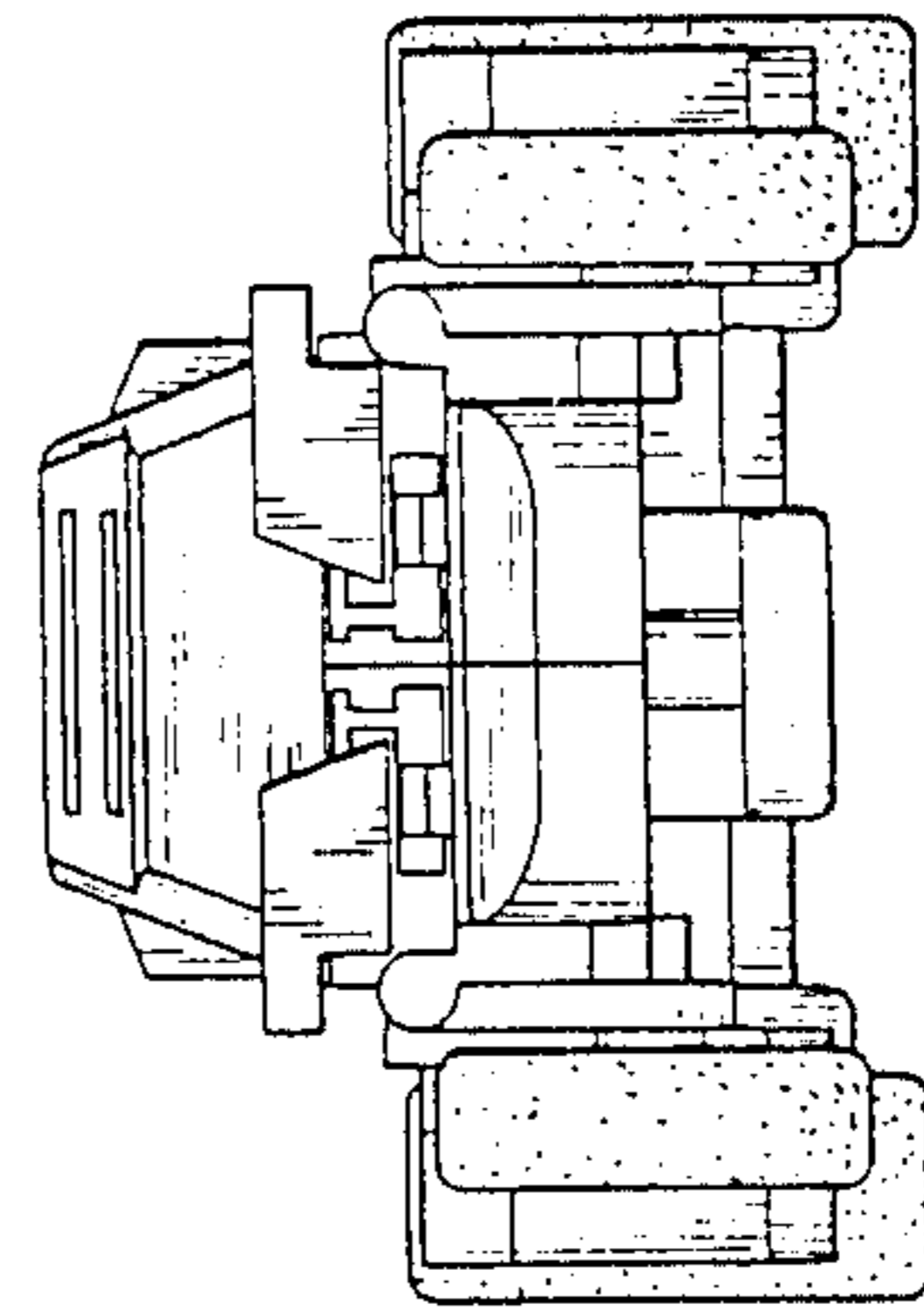

FIG. 3

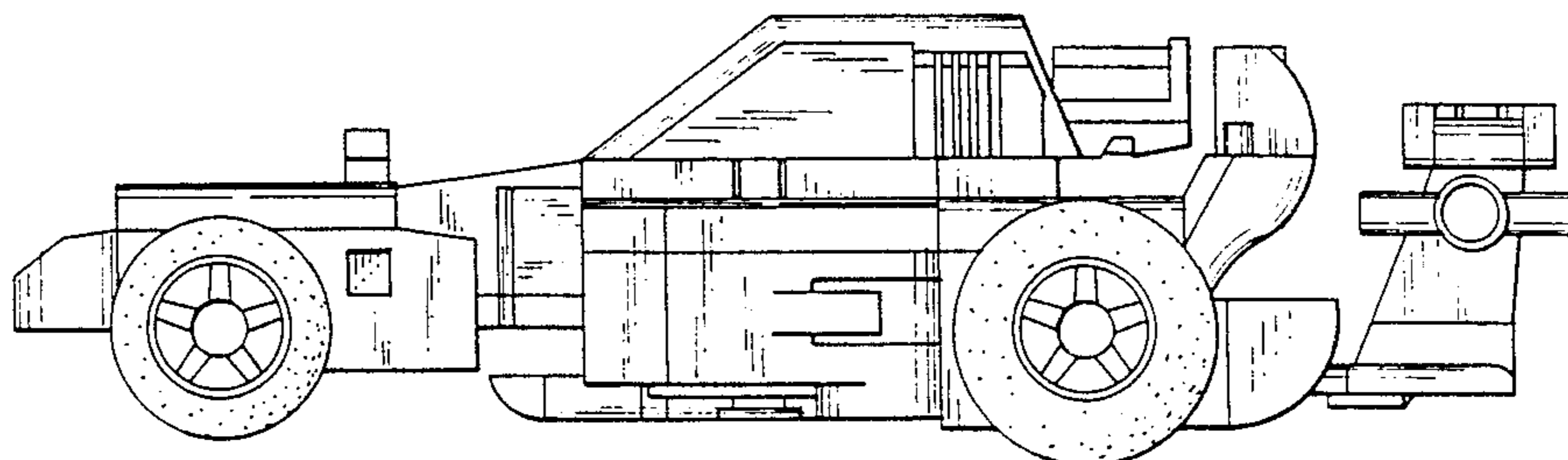

FIG. 4

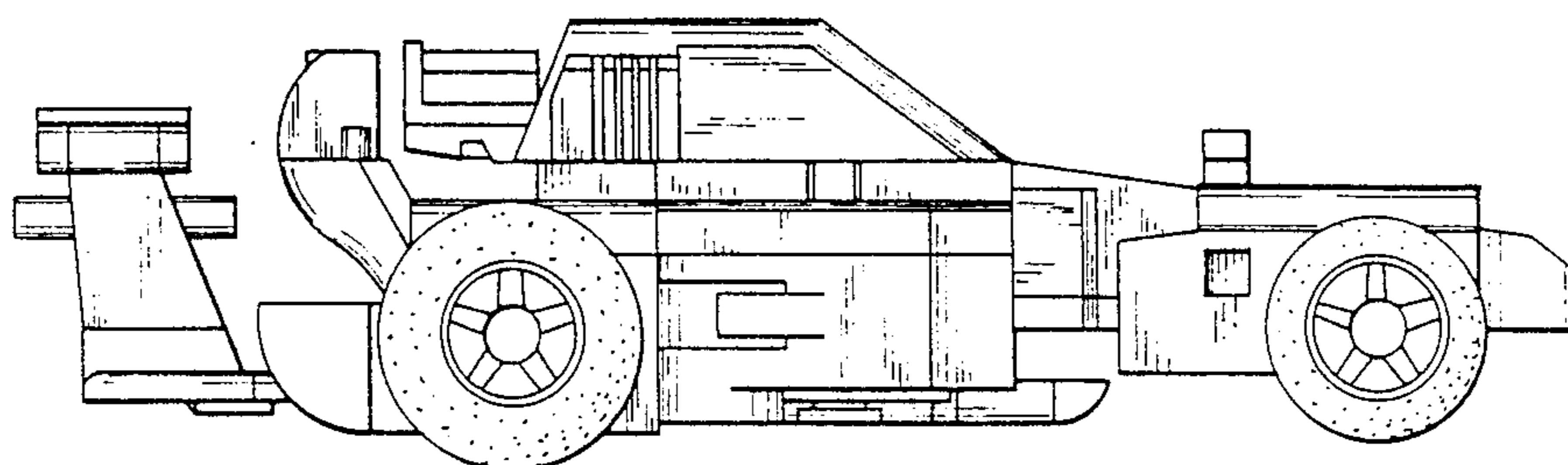
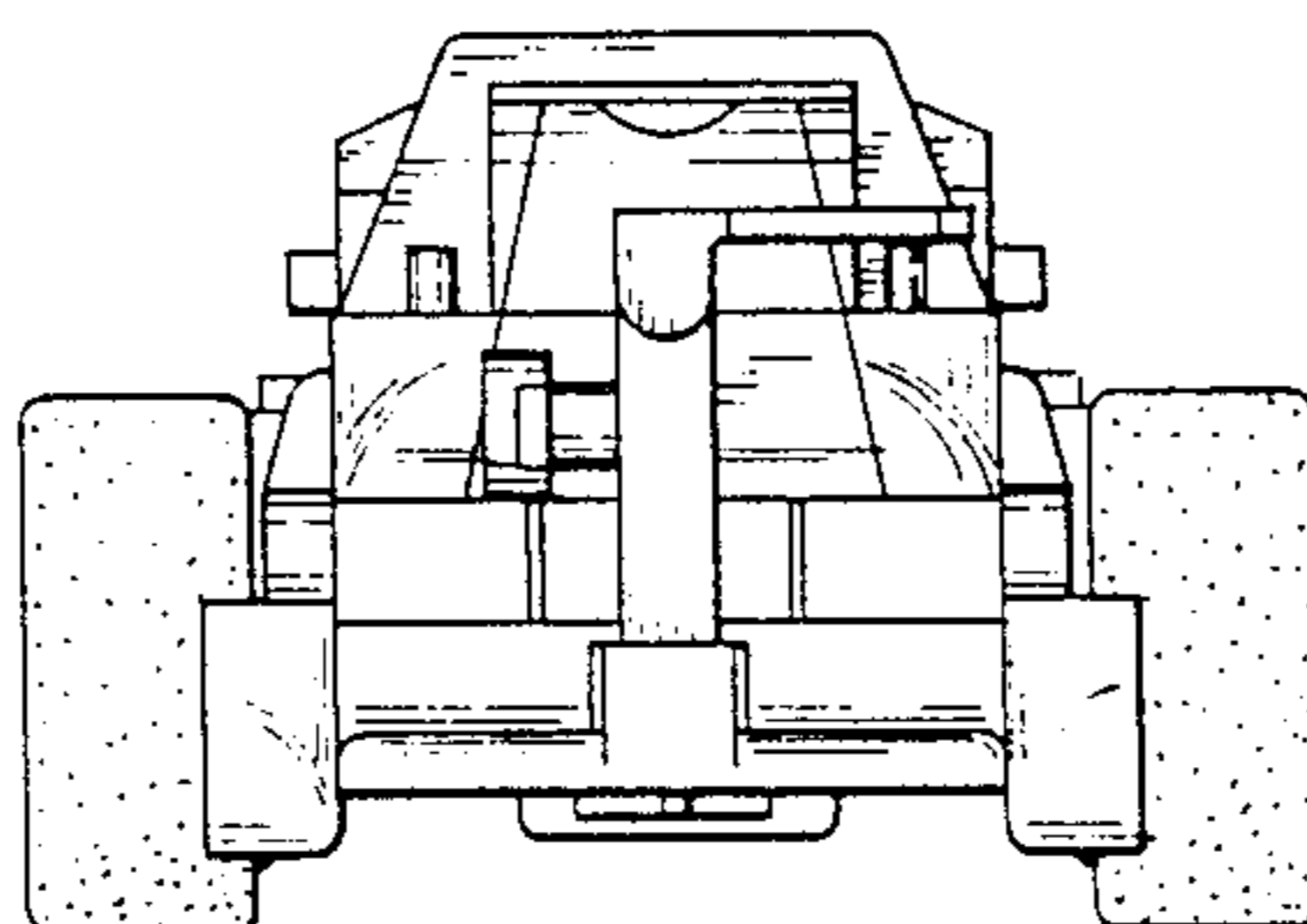

FIG. 5



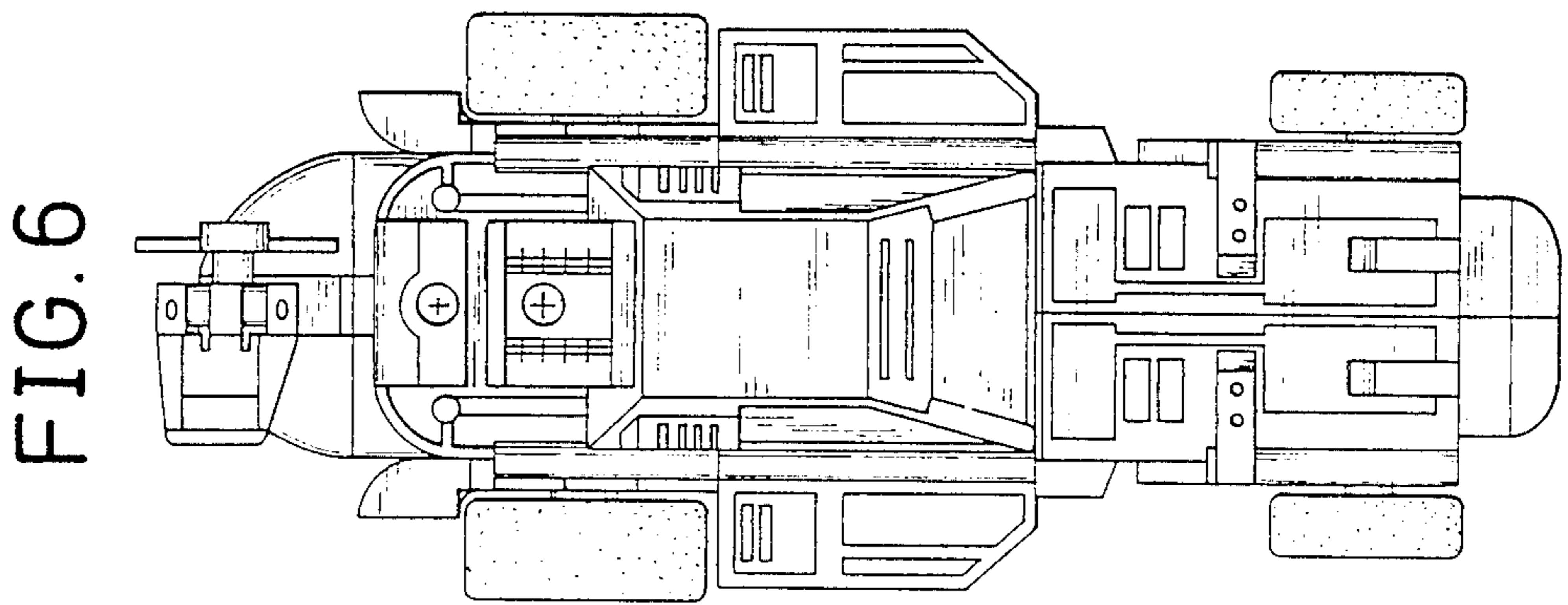
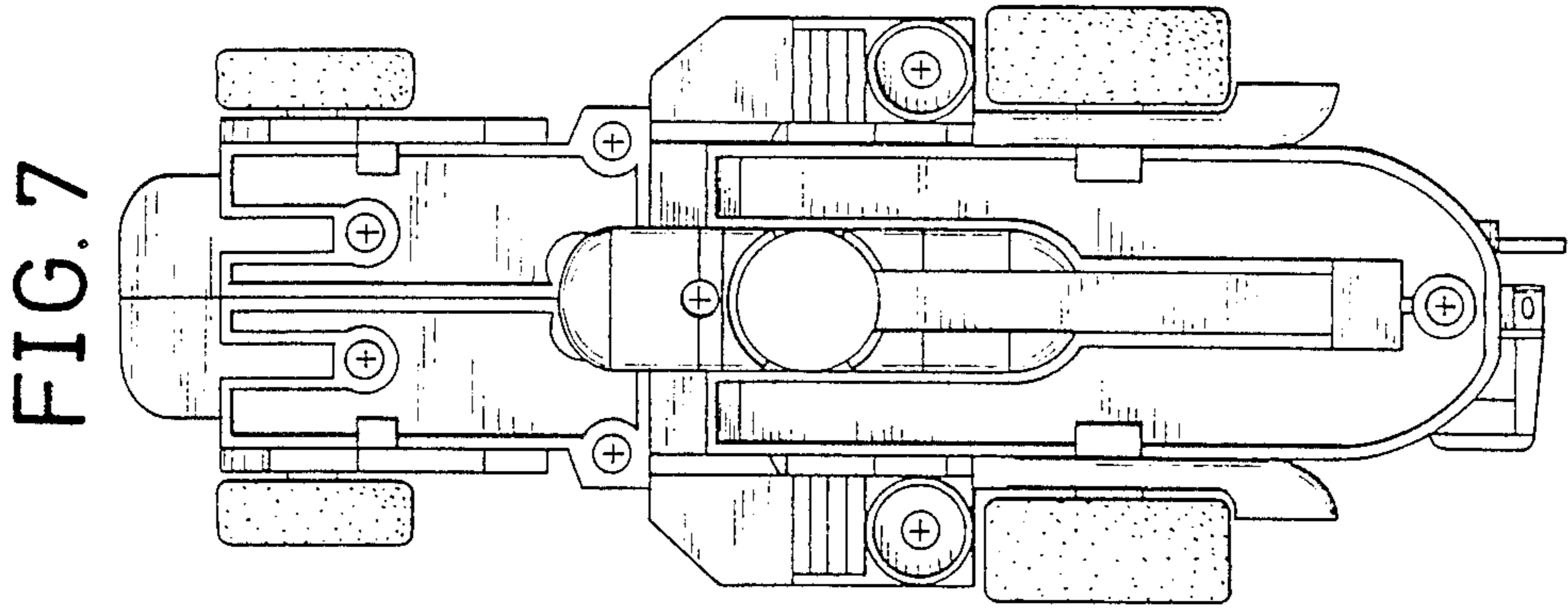

FIG. 8

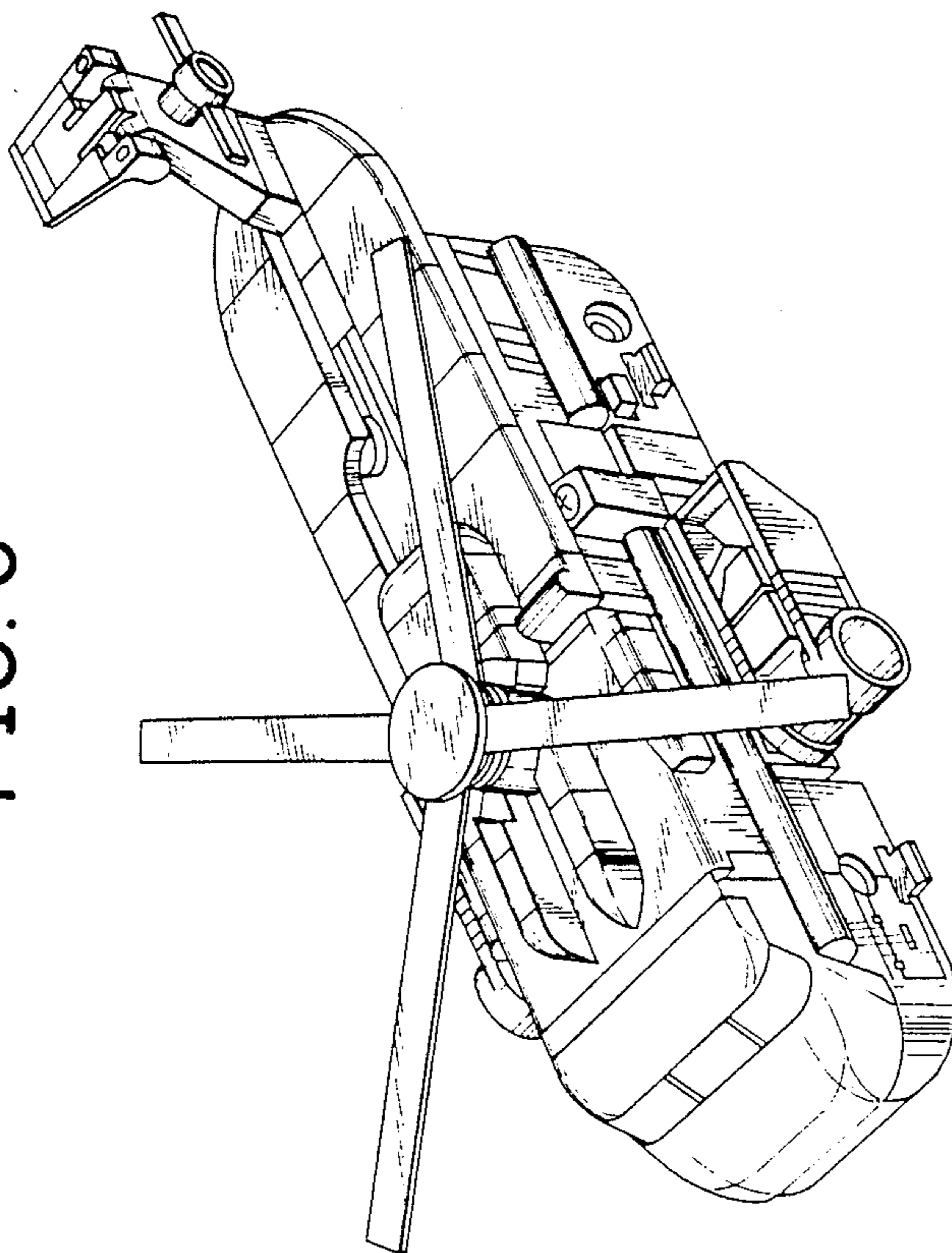

FIG. 9

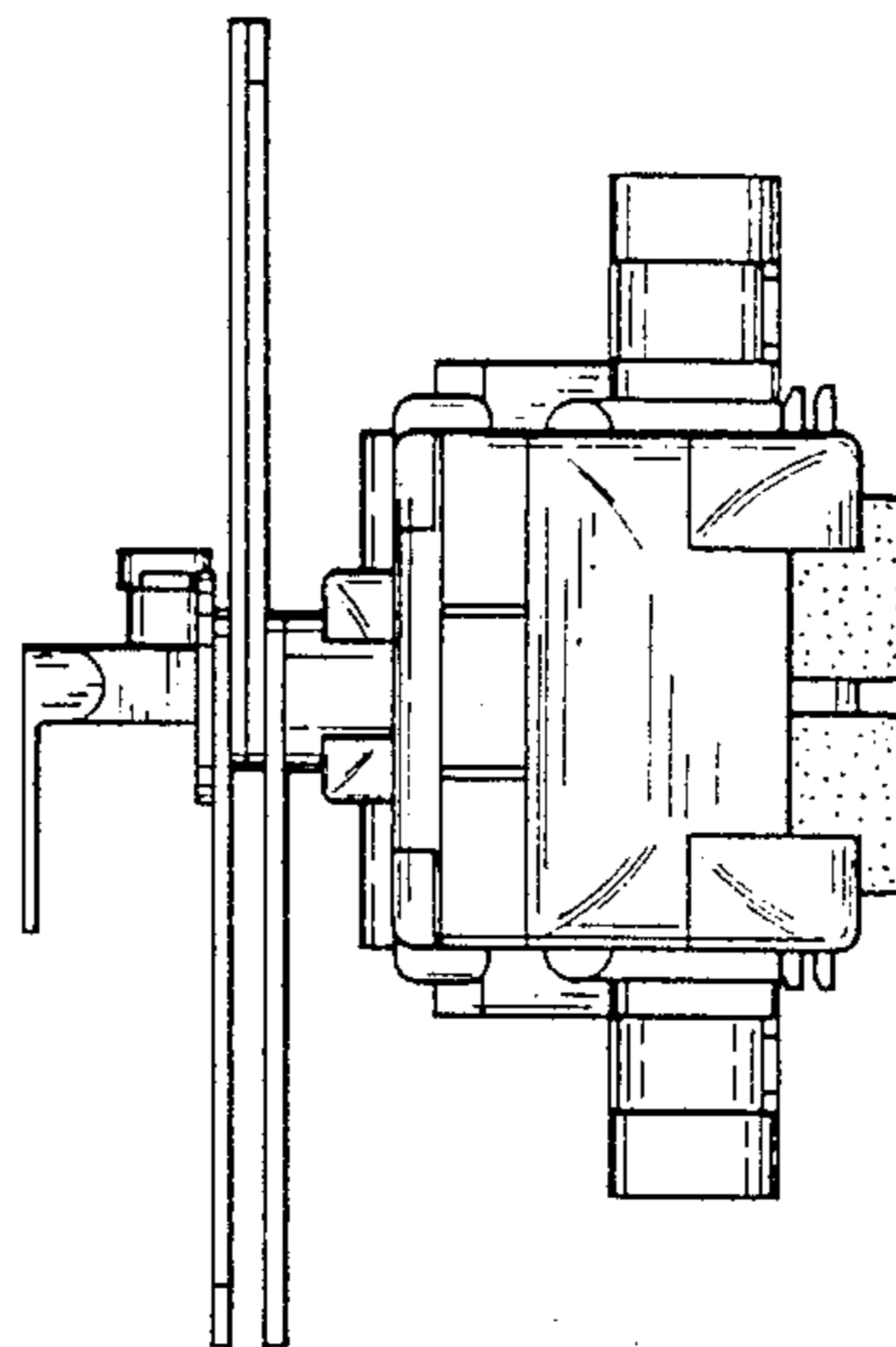

FIG.10

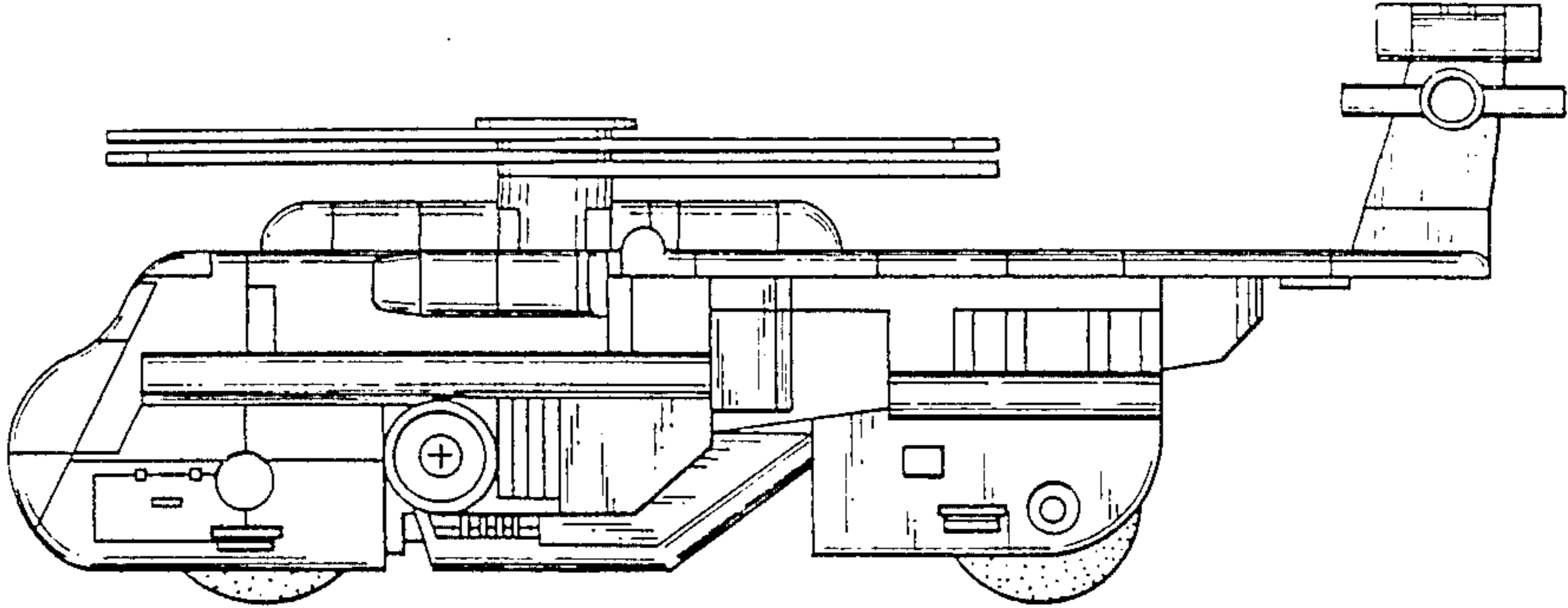

FIG.11

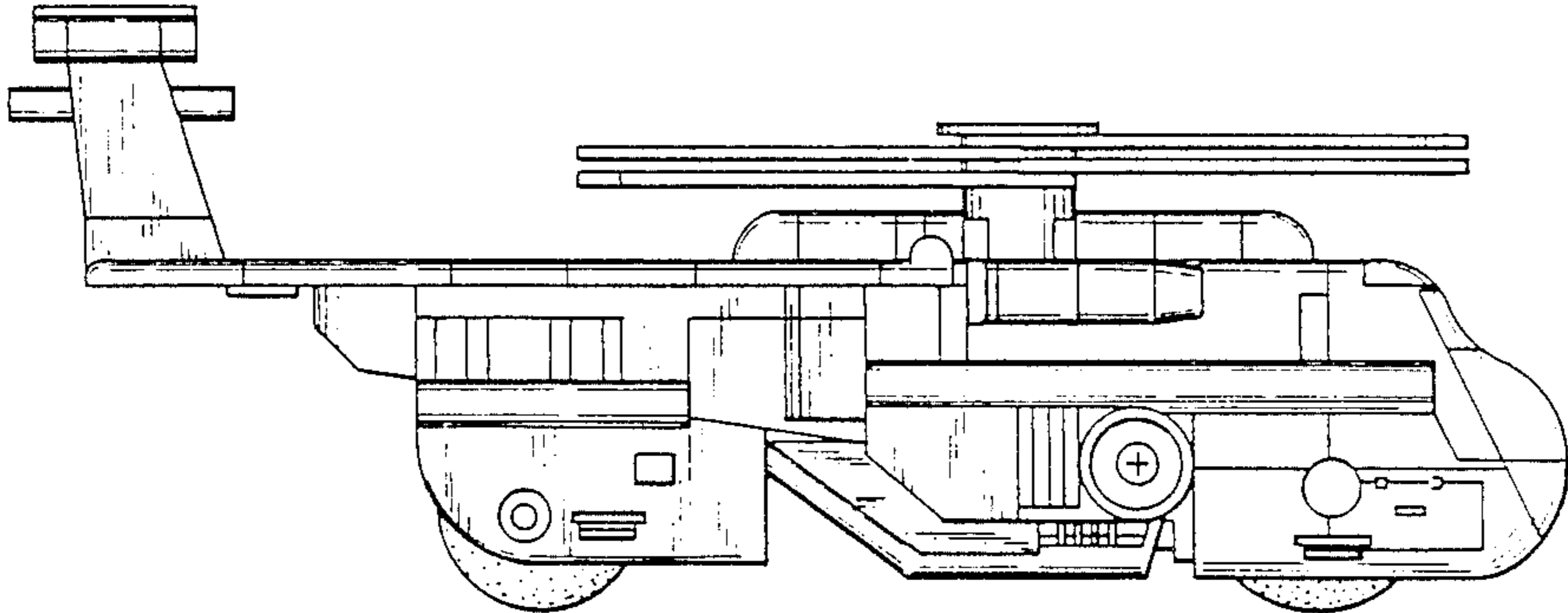

FIG.12

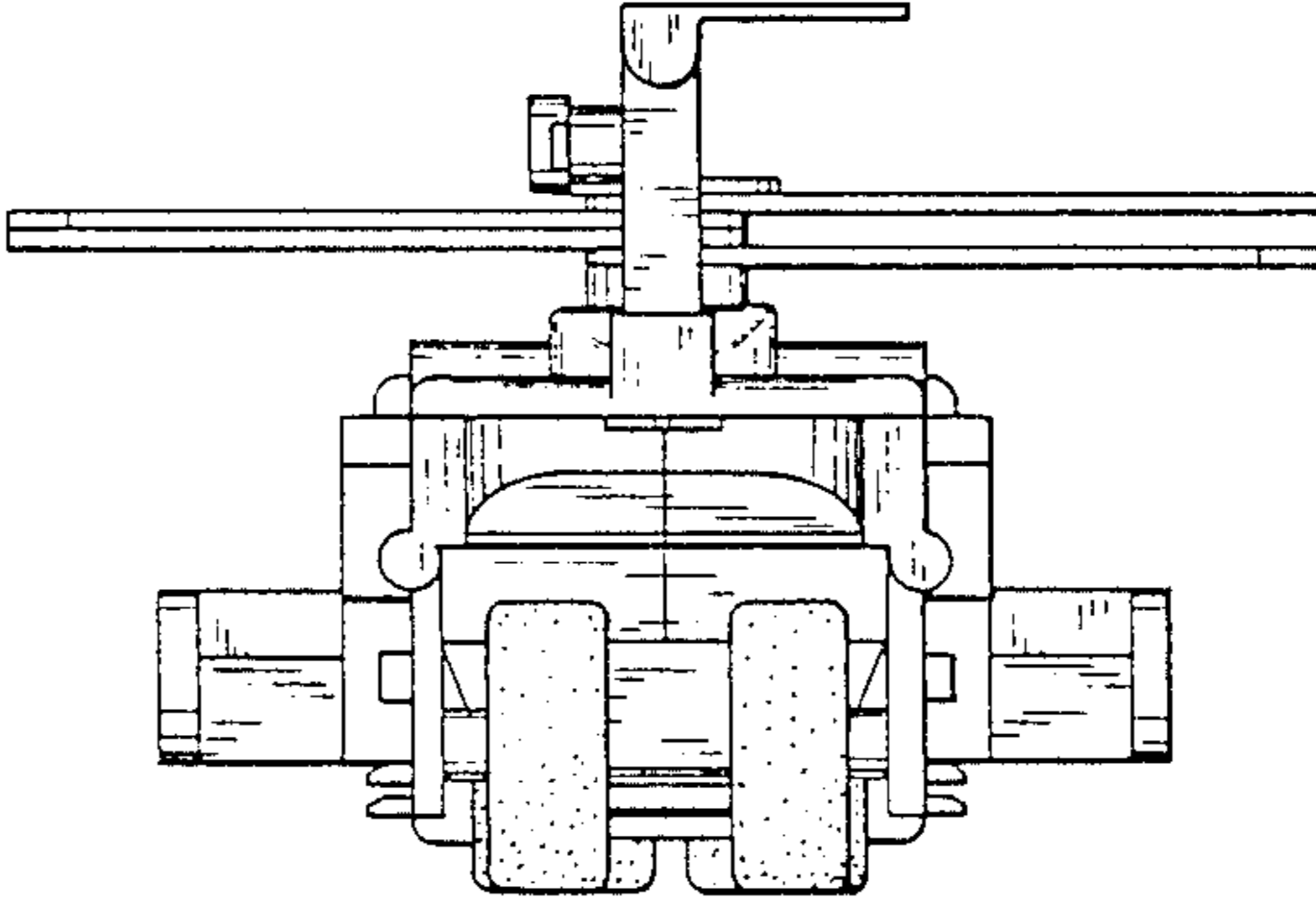

FIG.14

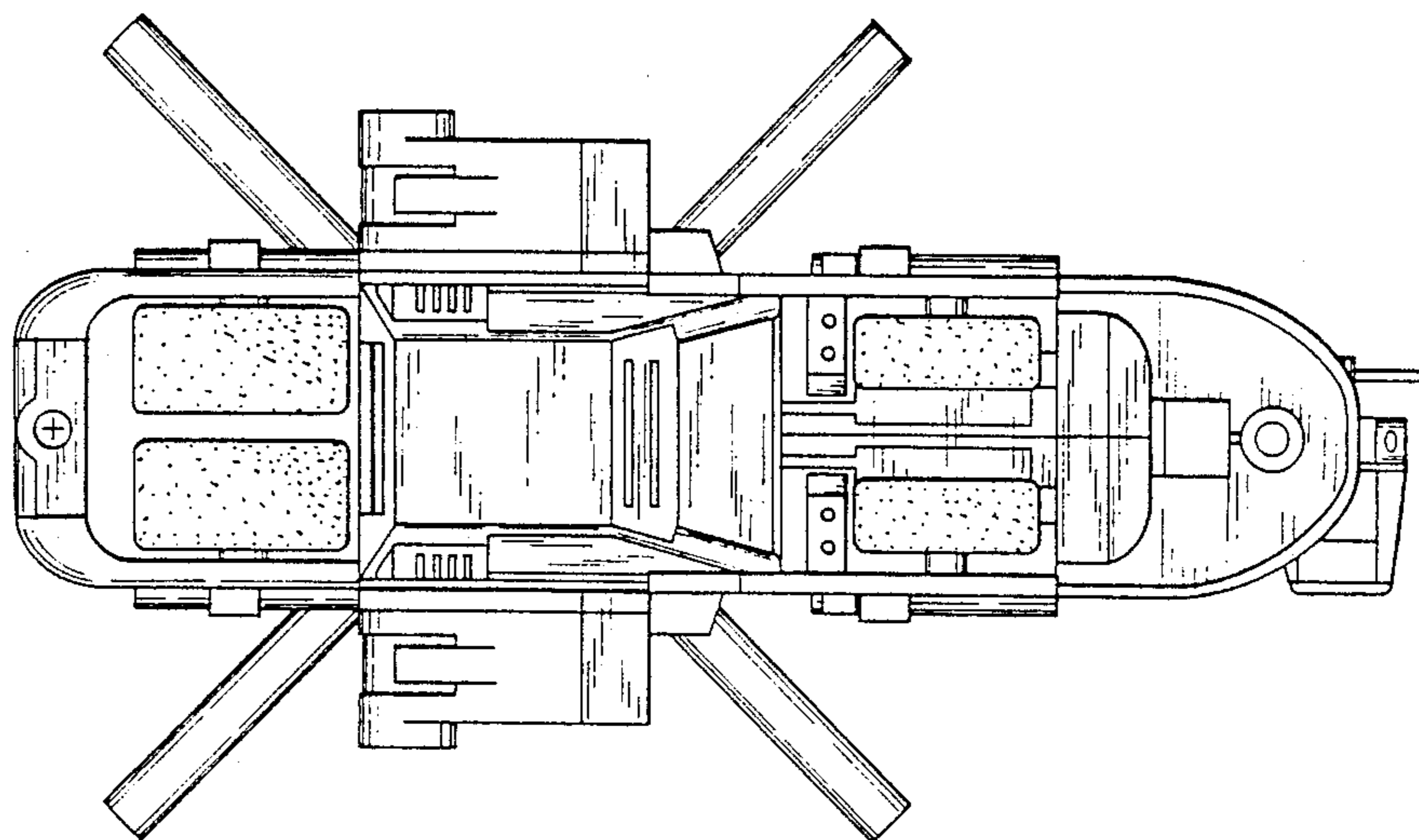

FIG.13

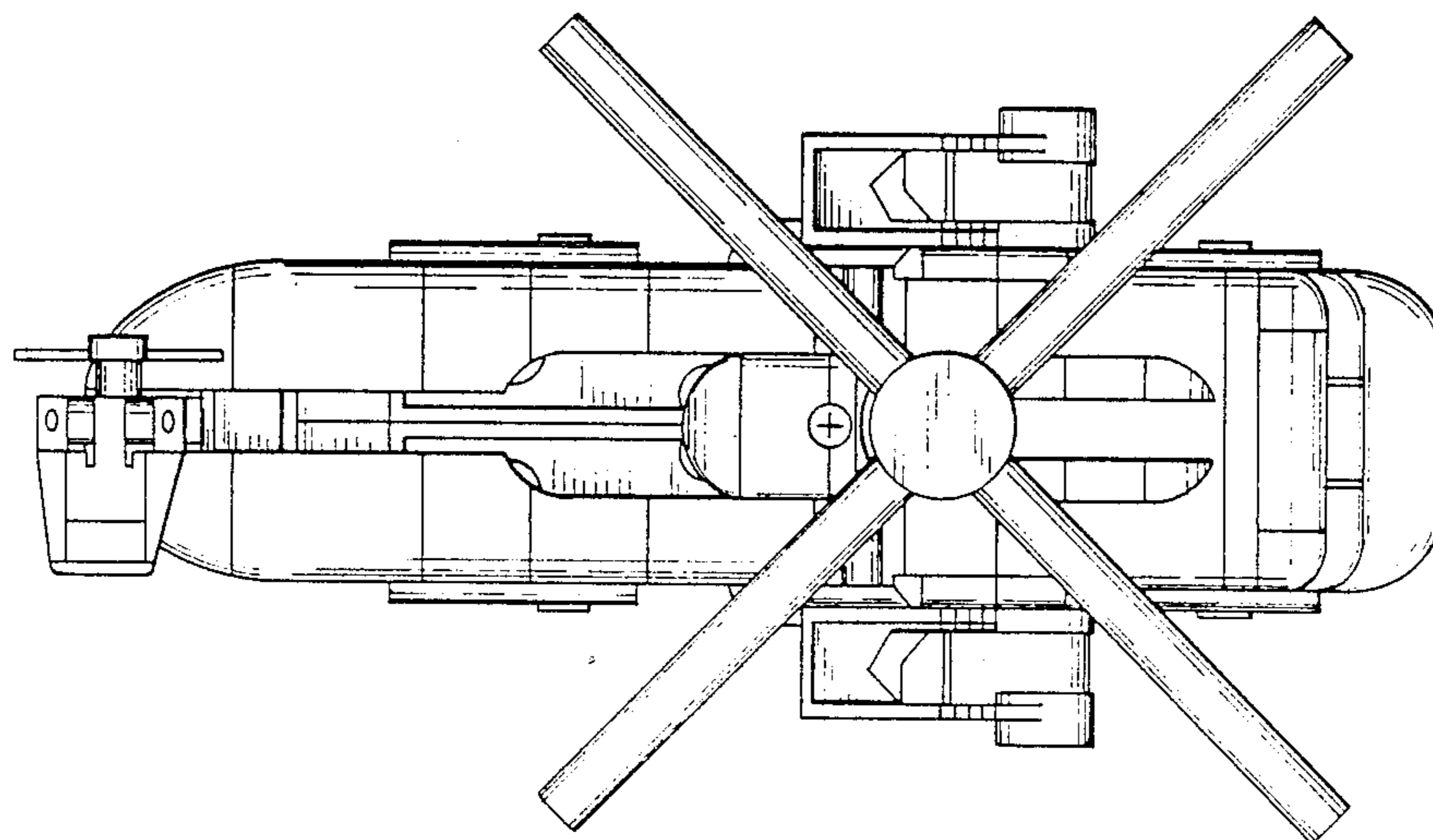

FIG.17

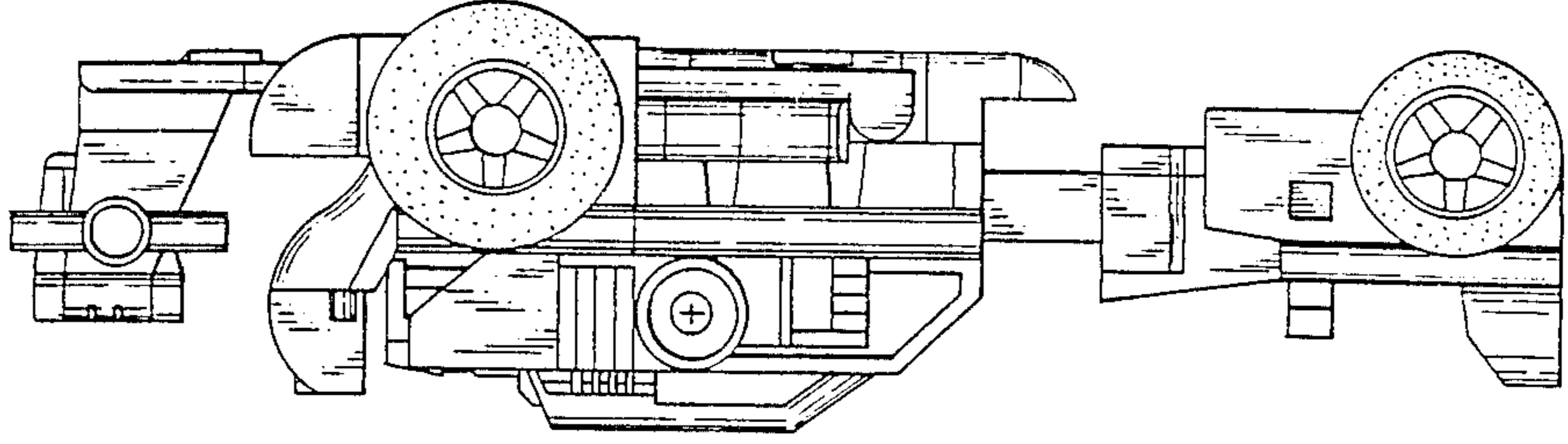

FIG.16

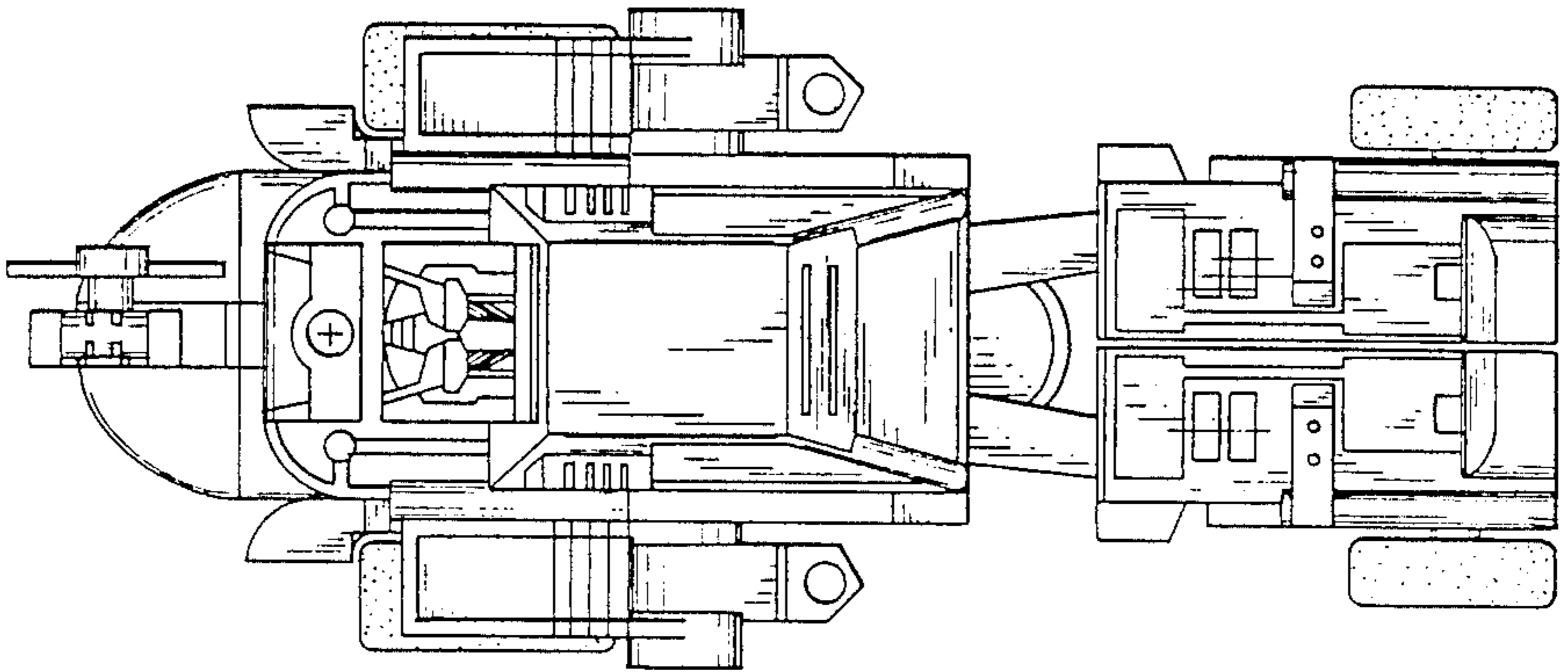

FIG.15

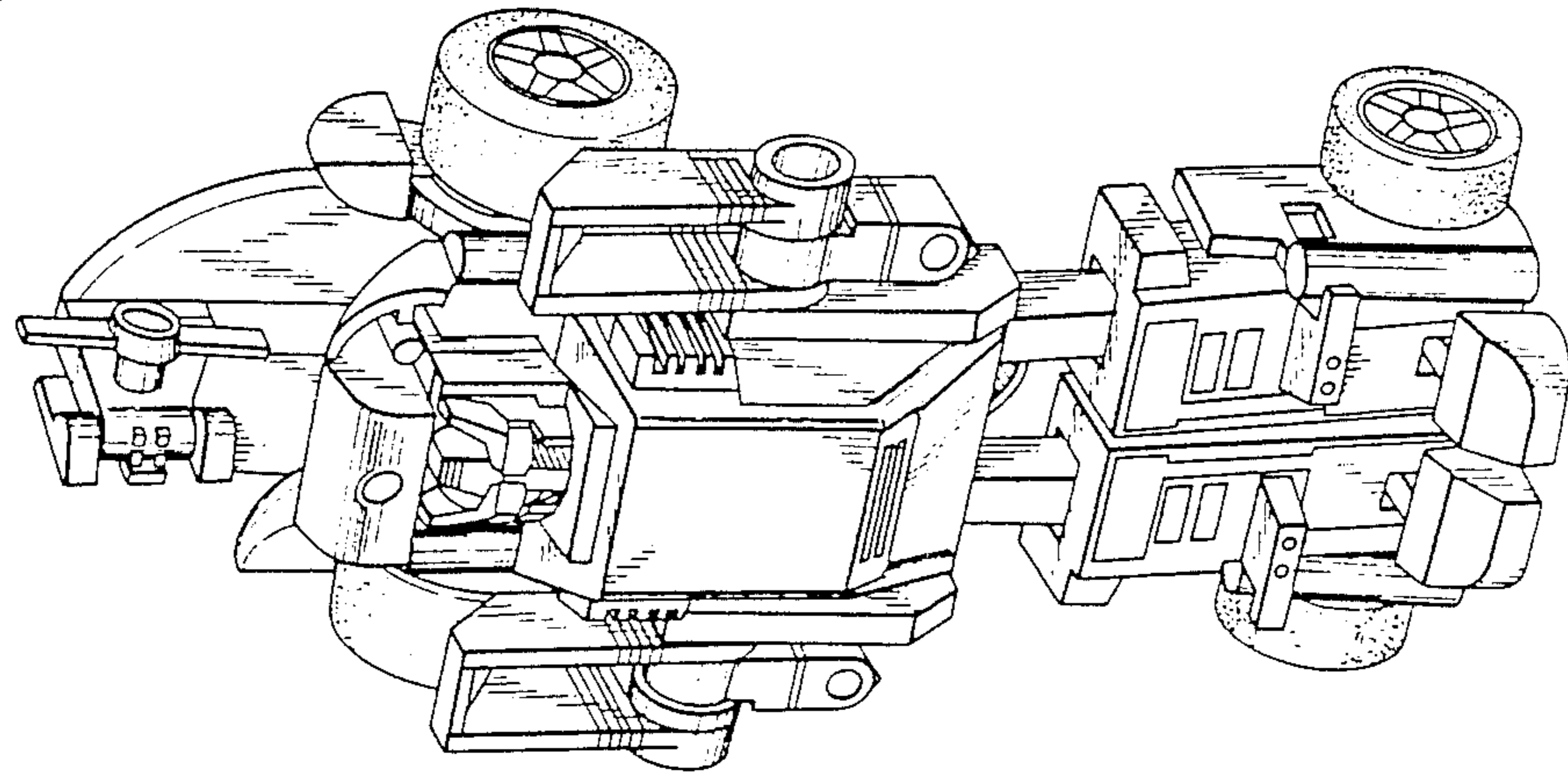



FIG.18

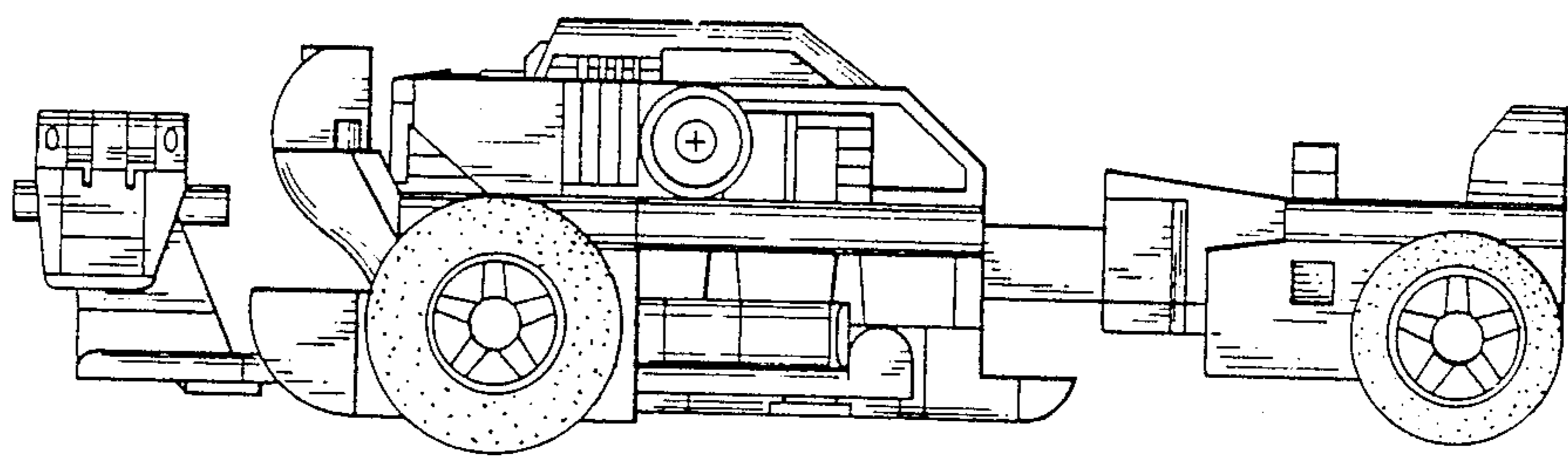

FIG.19

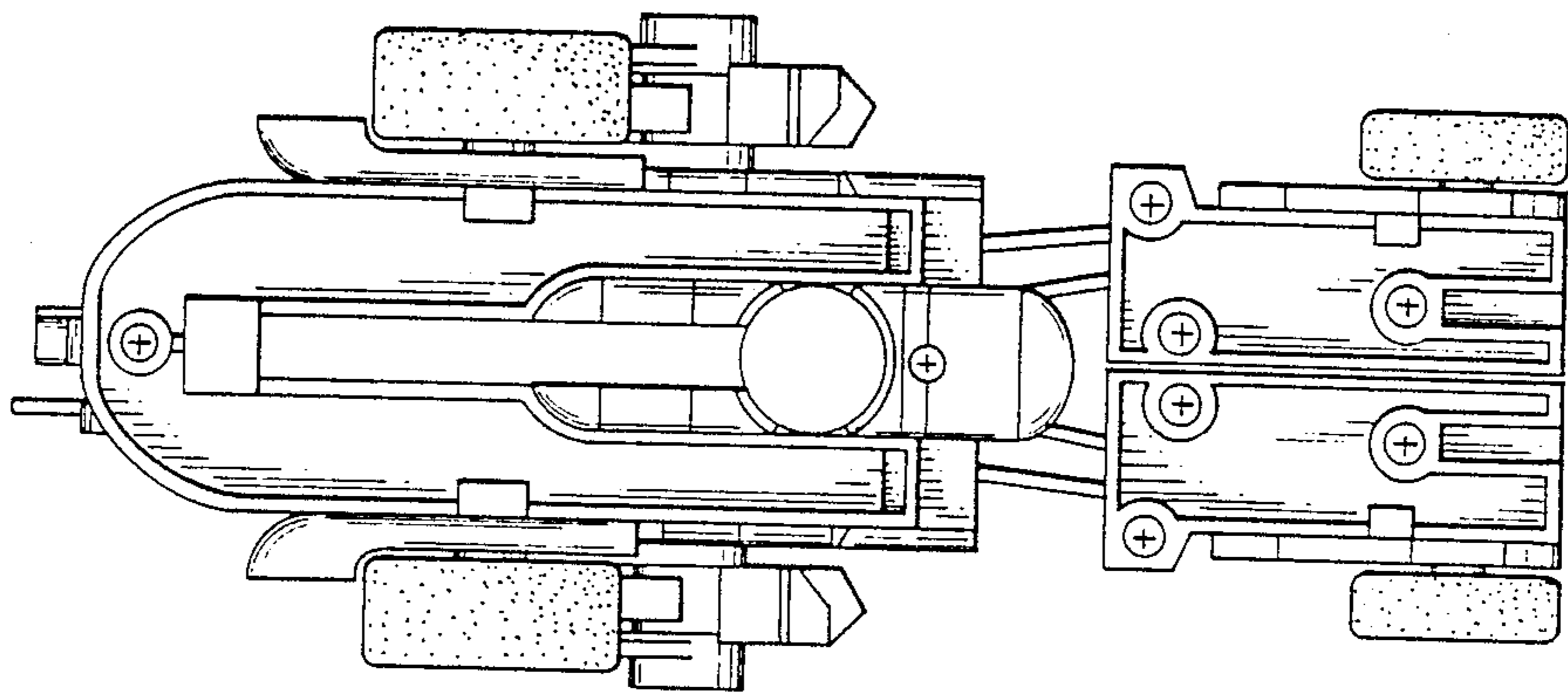

FIG.20

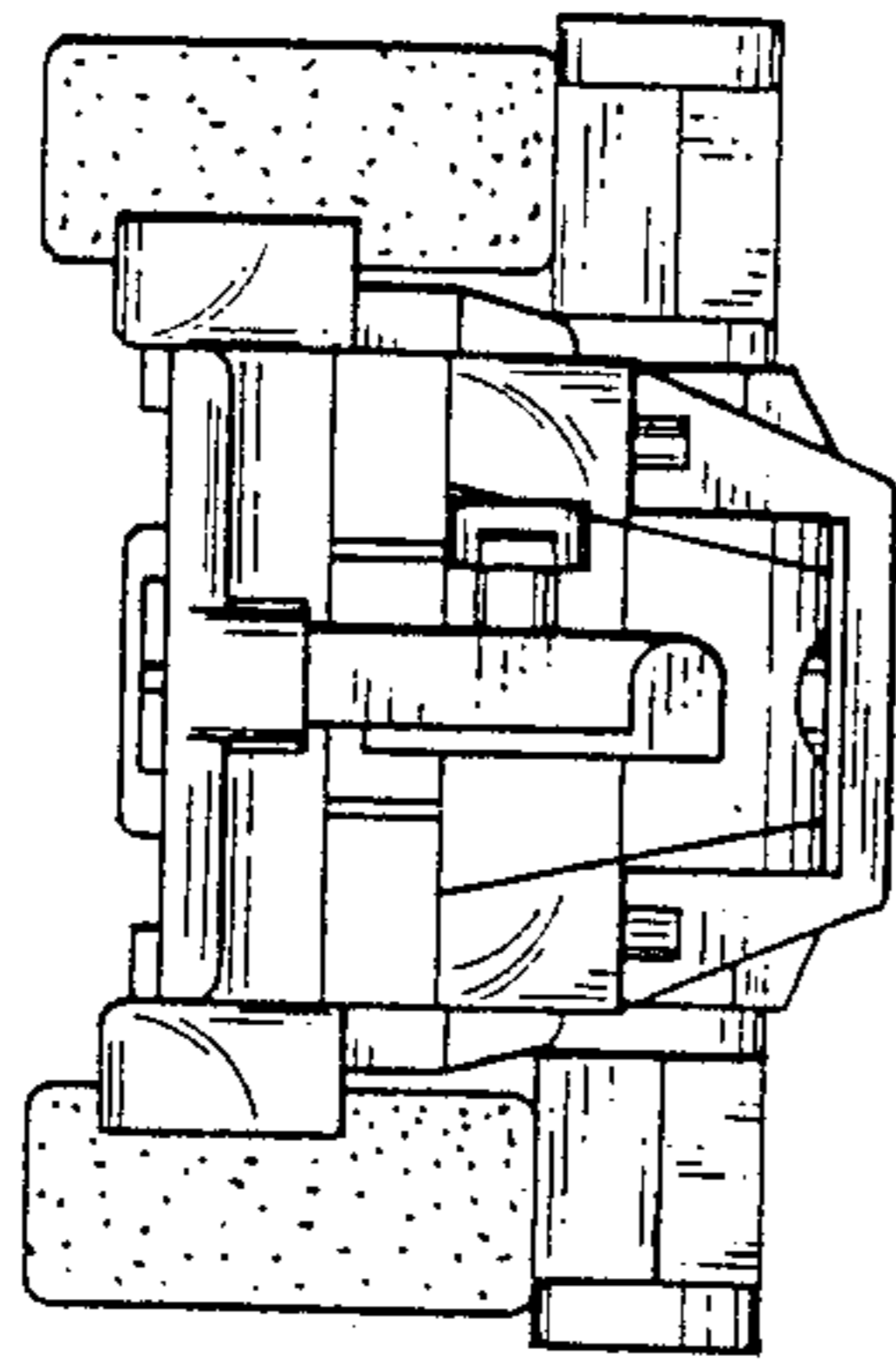

FIG.21

