

[54] **VEHICLE TAILGATE**

[76] **Inventor: Donnie J. Smith, 916 Clairemont, Fort Worth, Tex. 76103**

[\*\*] **Term: 14 Years**

[21] **Appl. No.: 740,743**

[22] **Filed: Jun. 3, 1985**

[52] **U.S. Cl. .... D12/196**

[58] **Field of Search ..... D12/196; 296/50, 57 R**

[56] **References Cited**

**U.S. PATENT DOCUMENTS**

D. 250,014	10/1978	Jensen	.....	D12/196
3,083,630	4/1963	Thaxton	.....	D12/181
4,165,118	8/1979	Jensen	.....	296/50

**OTHER PUBLICATIONS**

Hot Rod, 1/85, p. 29, Pickup Truck Tailgate, bottom right side of page.

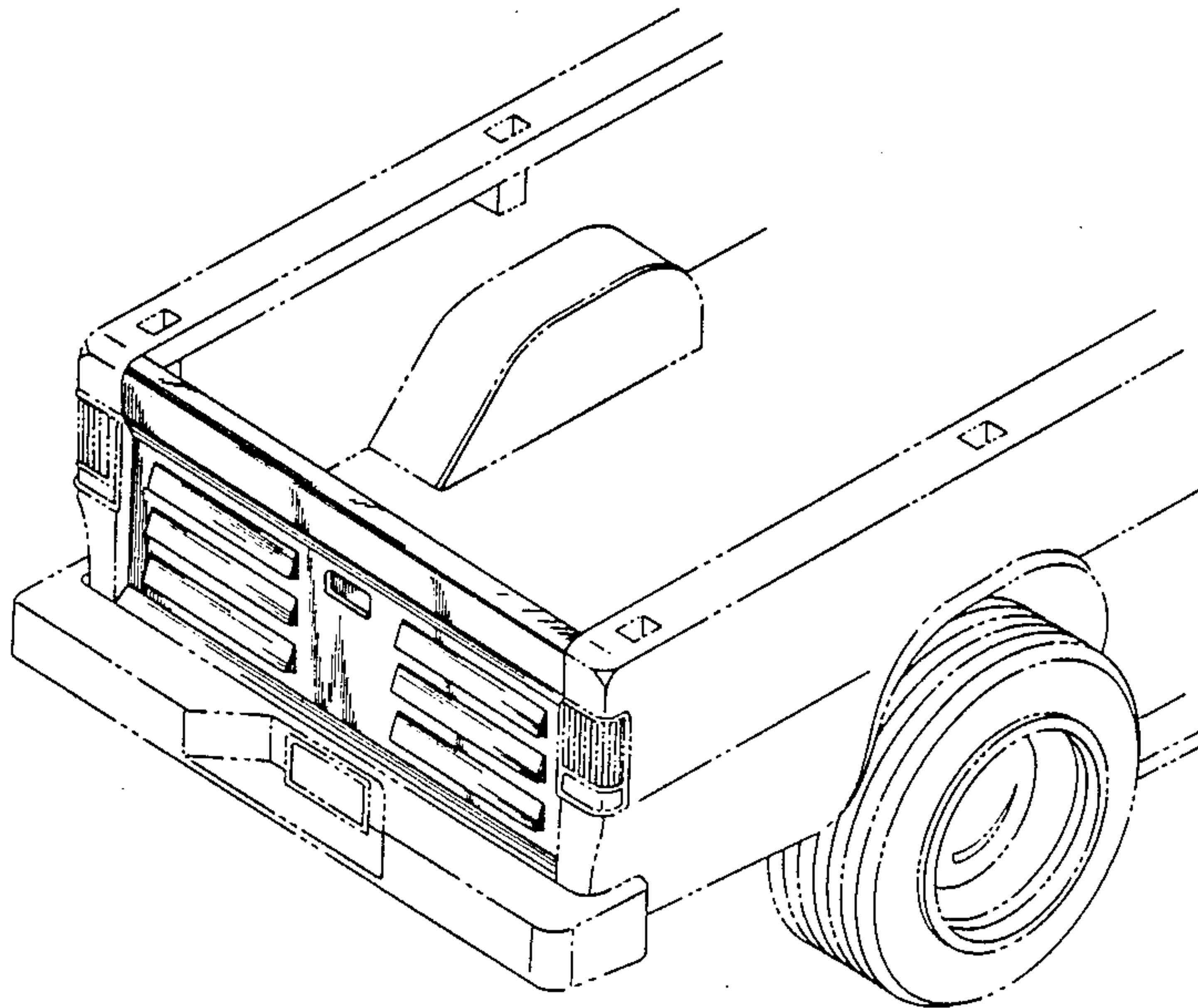
*Primary Examiner*—James M. Gandy  
*Attorney, Agent, or Firm*—Charles D. Gunter, Jr.

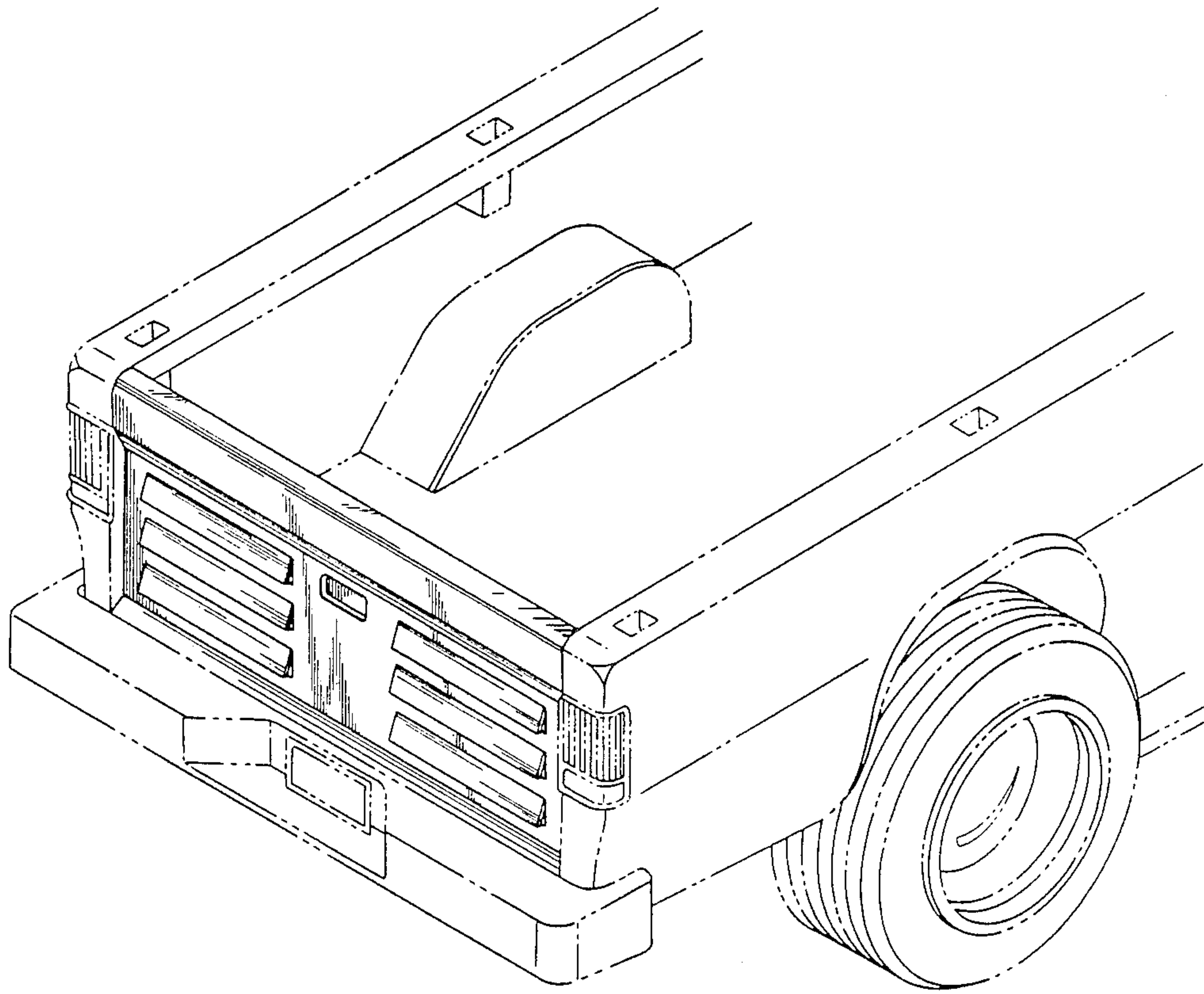
[57] **CLAIM**

The ornamental design for a vehicle tailgate, as shown and described.

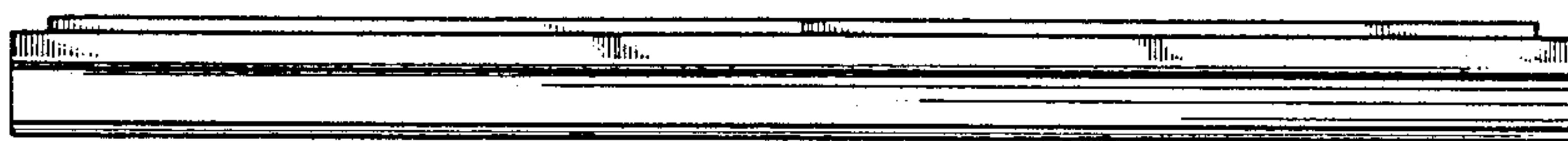
**DESCRIPTION**

FIG. 1 is a front perspective view of a vehicle tailgate showing my new design with the louvers in open condition it being understood that the fragmentary broken line showing of the pickup truck is for illustrative purposes only and forms no part of the claimed design; FIG. 2 is an enlarged top plan view thereof; FIG. 3 is an enlarged front elevation view thereof; FIG. 4 is an enlarged side elevation view thereof it being understood that the opposite side is a mirror image of the side shown; FIG. 5 is an enlarged rear elevation view thereof; and FIG. 6 is an enlarged bottom plan view thereof.

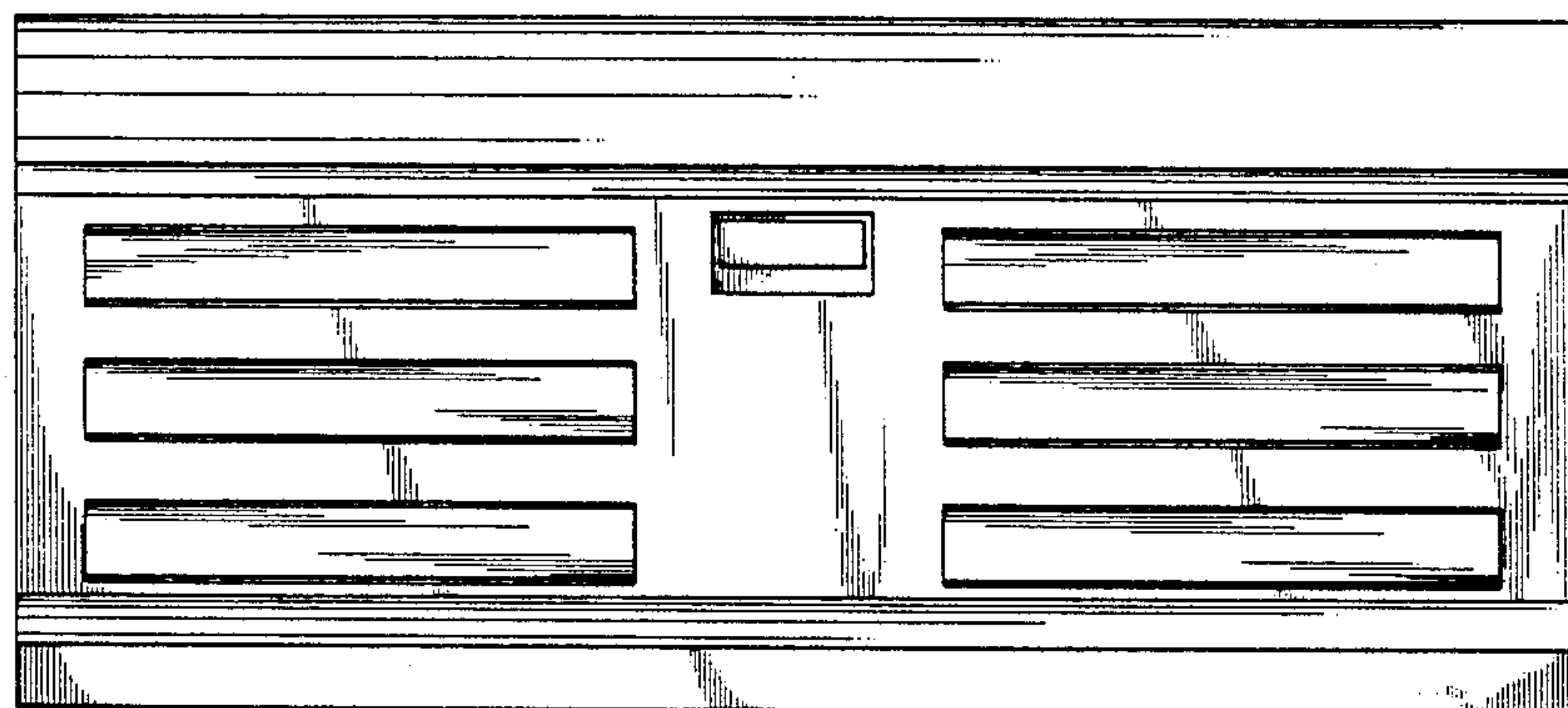




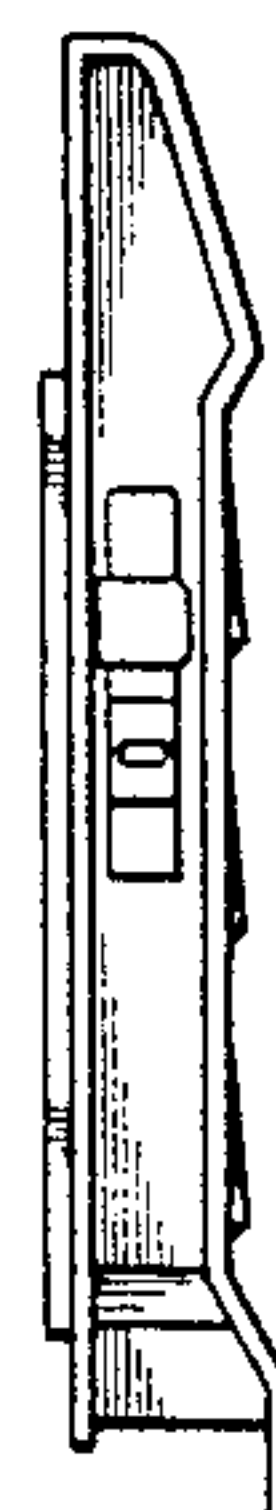
*Fig. 1*



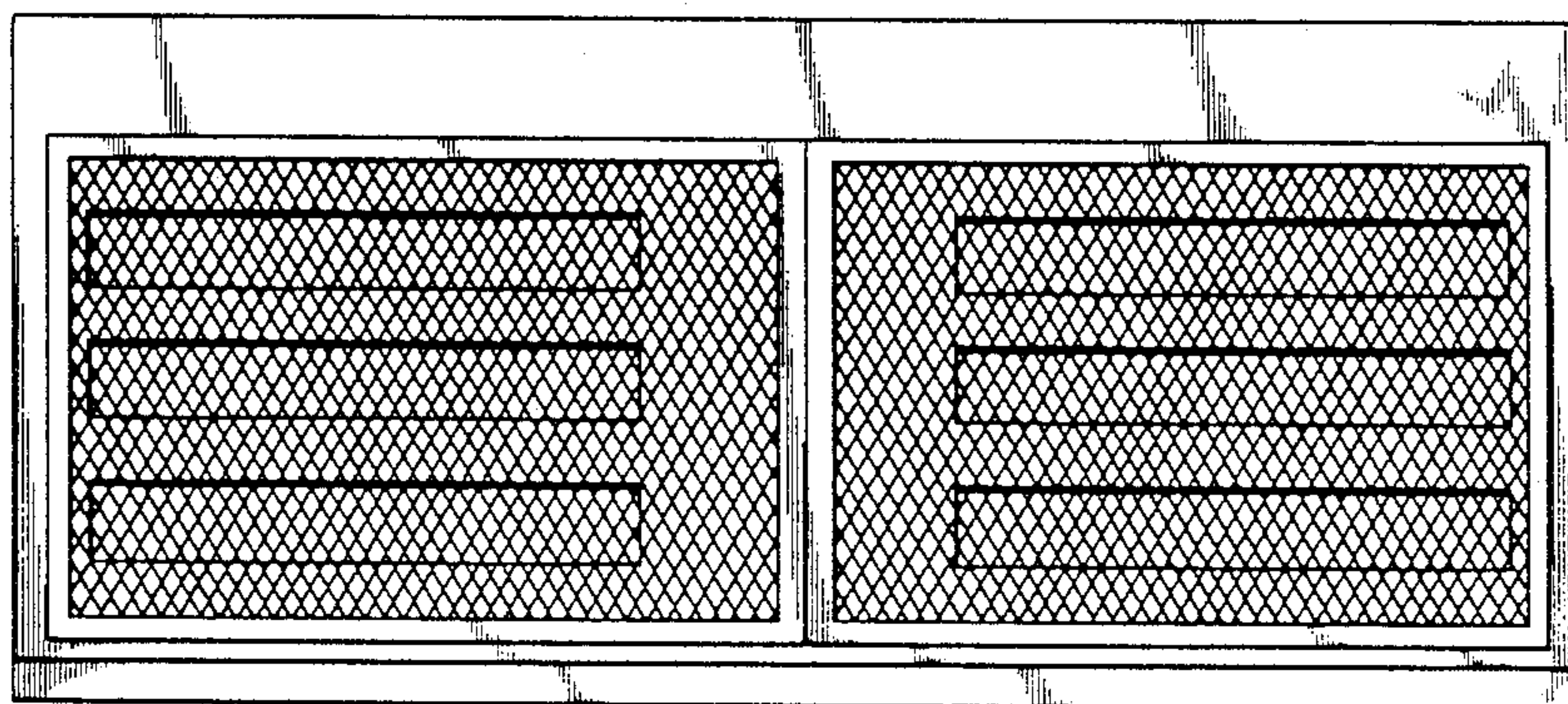
*Fig. 2*



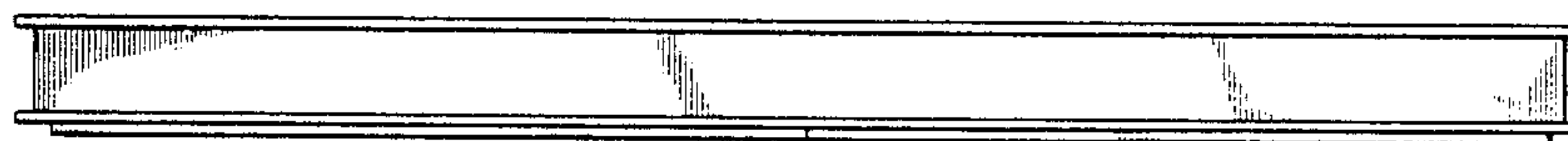
*Fig. 3*



*Fig. 4*



*Fig. 5*



*Fig. 6*