

[54] MOTORCYCLE

[75] Inventors: Akio Matsuzaki; Mamoru Isomura; Hiroyuki Kobayashi, all of Saitama, Japan

[73] Assignee: Honda Giken Kogyo Kabushiki Kaisha, Tokyo, Japan

[**] Term: 14 Years

[21] Appl. No.: 722,353

[22] Filed: Apr. 12, 1985

[30] Foreign Application Priority Data

Oct. 16, 1984 [JP] Japan 59-42699

[52] U.S. Cl. D12/110

[58] Field of Search D12/110; 180/219

[56] References Cited

U.S. PATENT DOCUMENTS

D. 269,170 5/1983 Aoyama et al. D12/110

OTHER PUBLICATIONS

Cycle World, 1/84, p. 31, Kawasaki KL600, bottom right side of page.

Cycle World, 1/84, p. 33, Husqvarna 250 XC, top center of page.

Primary Examiner—James M. Gandy
Attorney, Agent, or Firm—Lyon & Lyon

[57] CLAIM

The ornamental design for a motorcycle, as shown.

DESCRIPTION

FIG. 1 is a front perspective view of a motorcycle showing our new design;

FIG. 2 is a back perspective view thereof;

FIG. 3 is a side elevation view of the left side thereof;

FIG. 4 is a side elevation view of the right side thereof;

FIG. 5 is a top plan view thereof; and

FIG. 6 is an oblique perspective view principally illustrating the right side thereof.

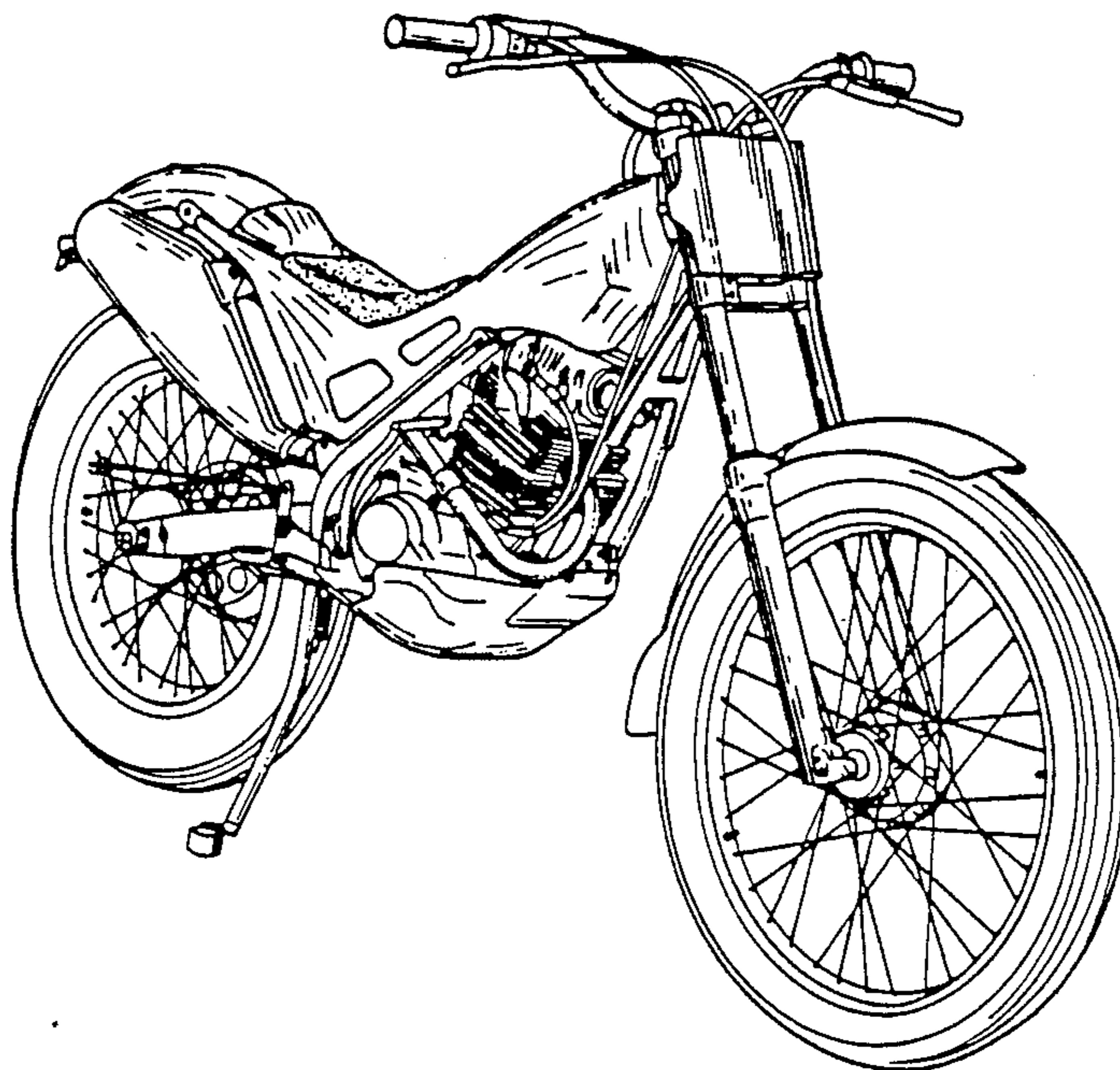

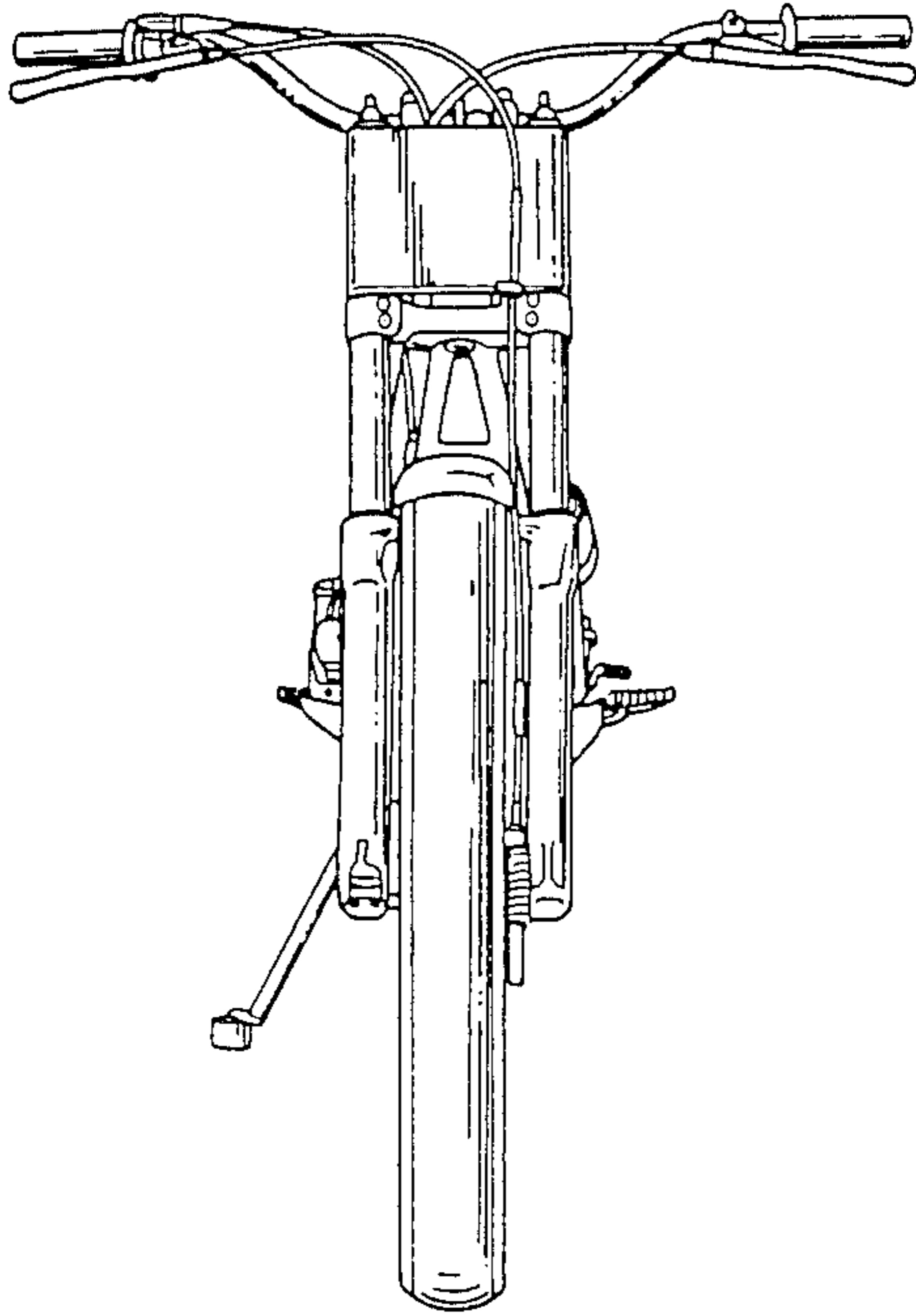

FIG. 1.

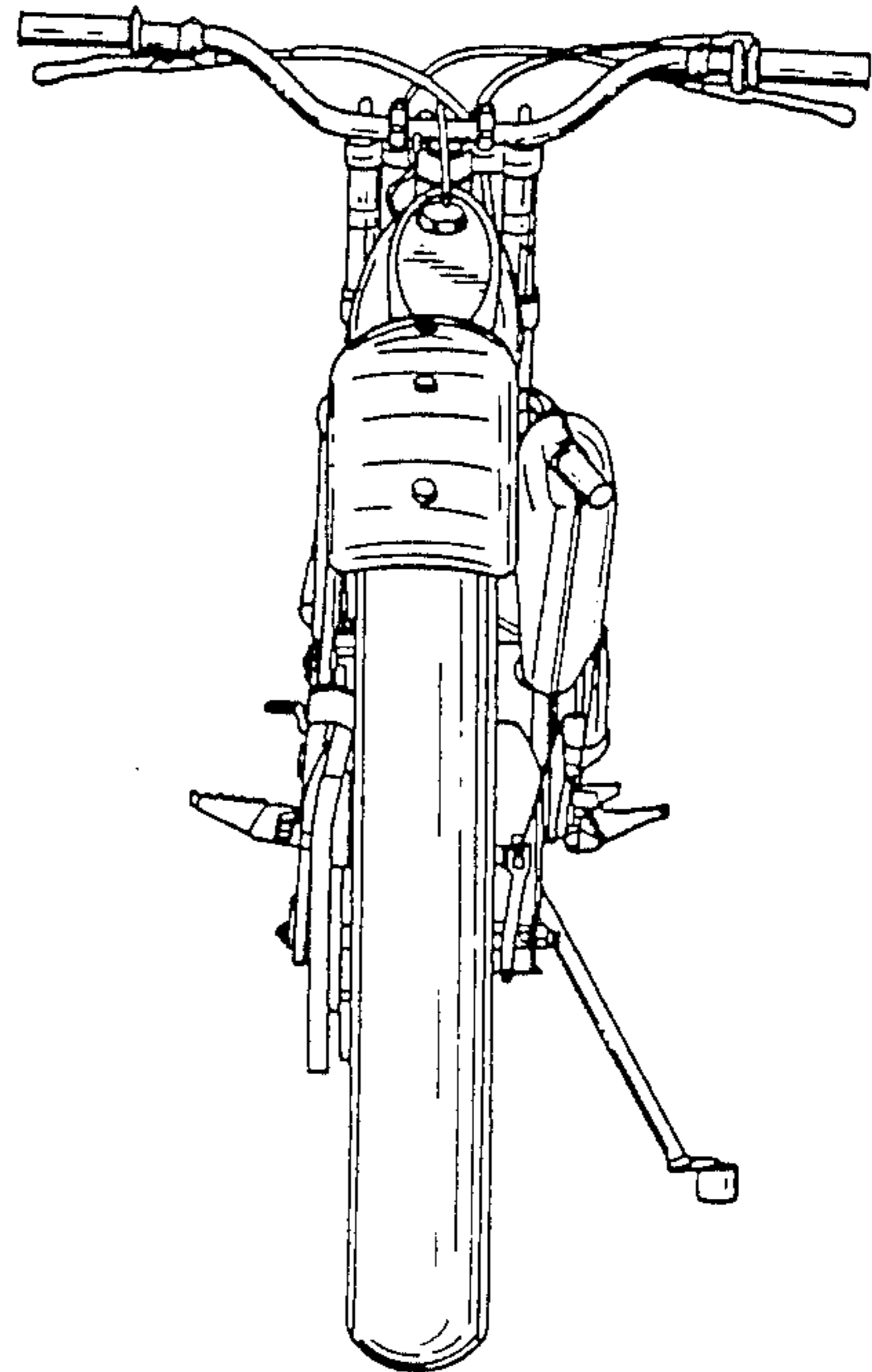

FIG. 2.

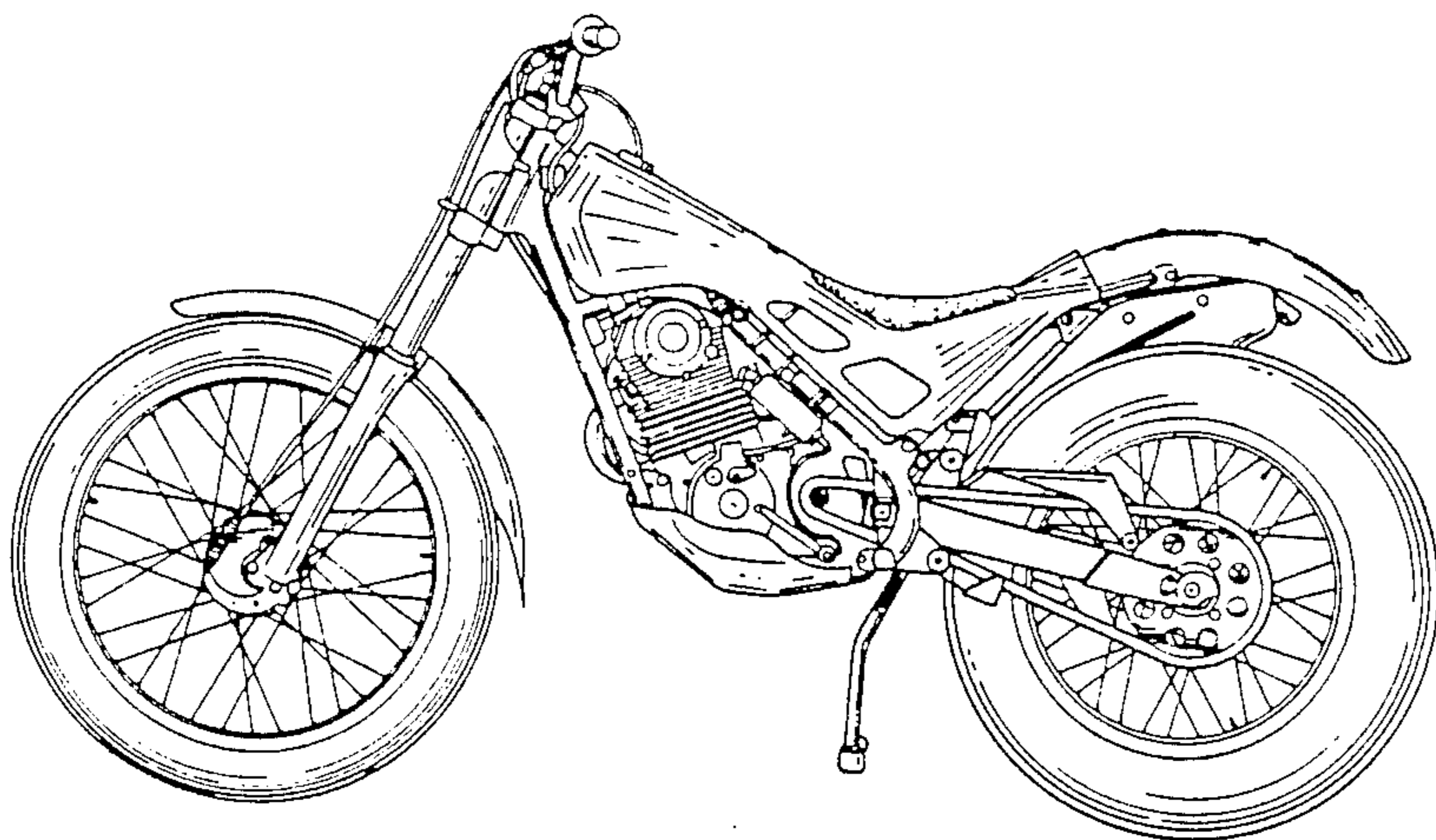

FIG. 3.

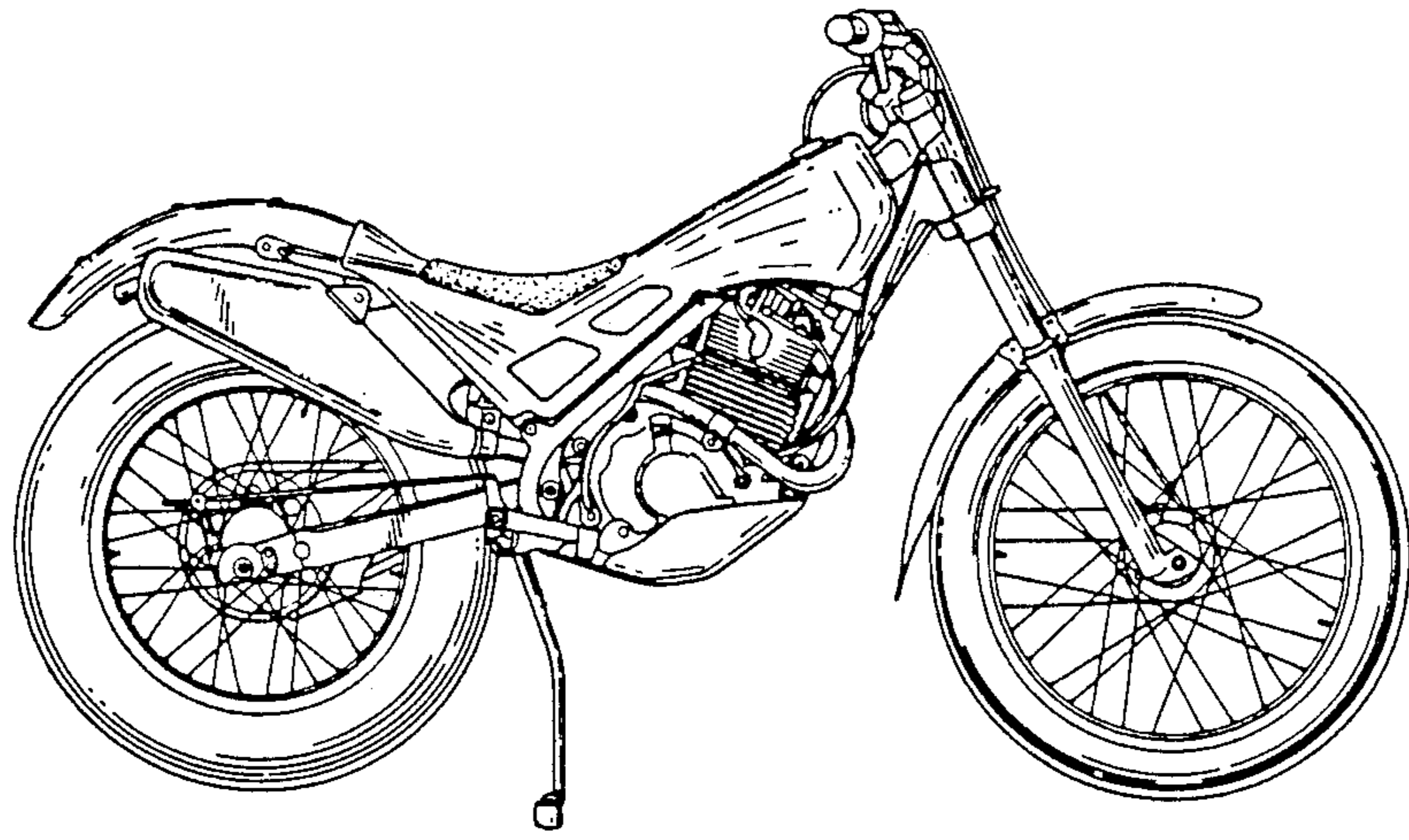

FIG. 4.

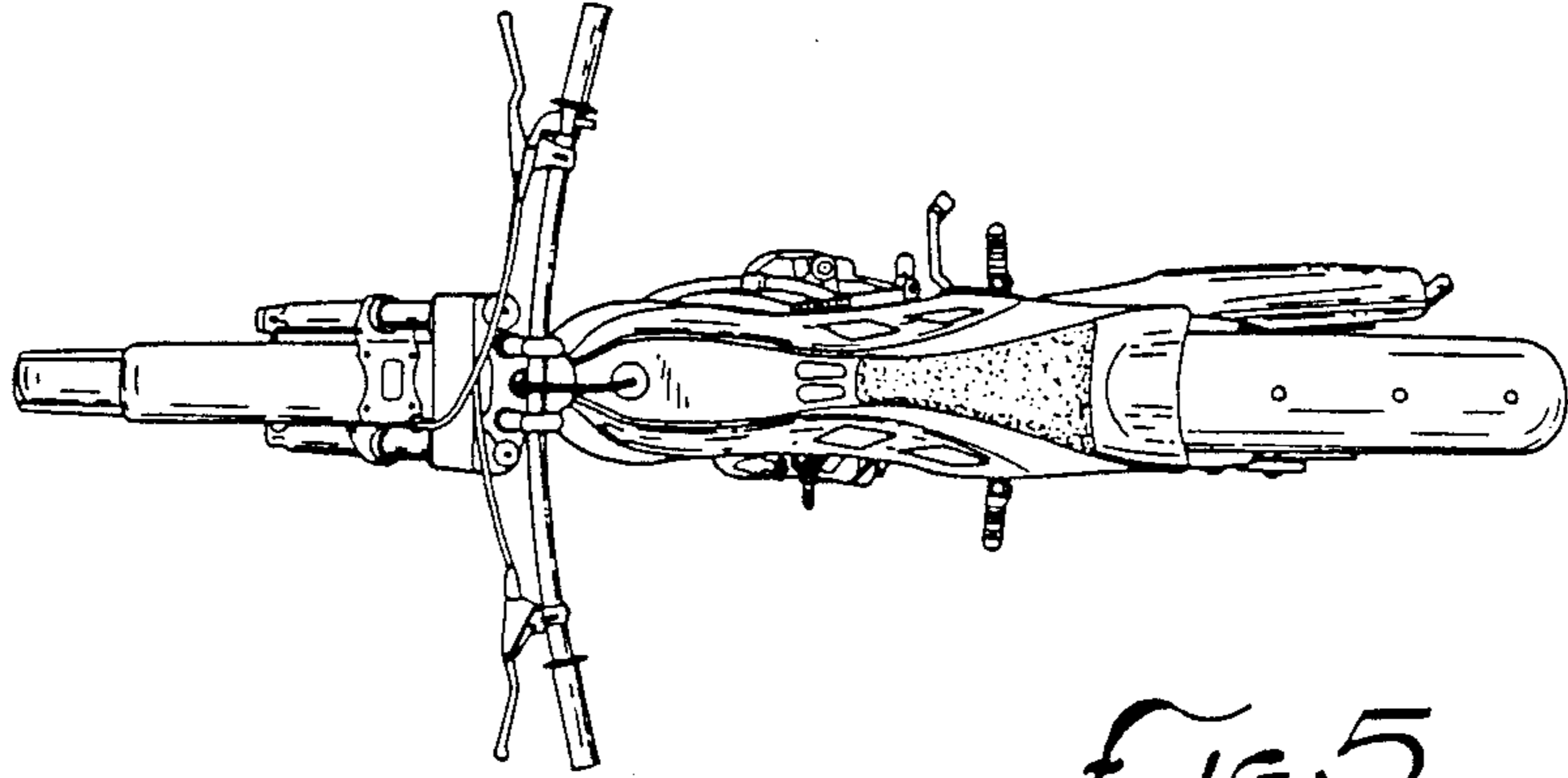

FIG. 5.

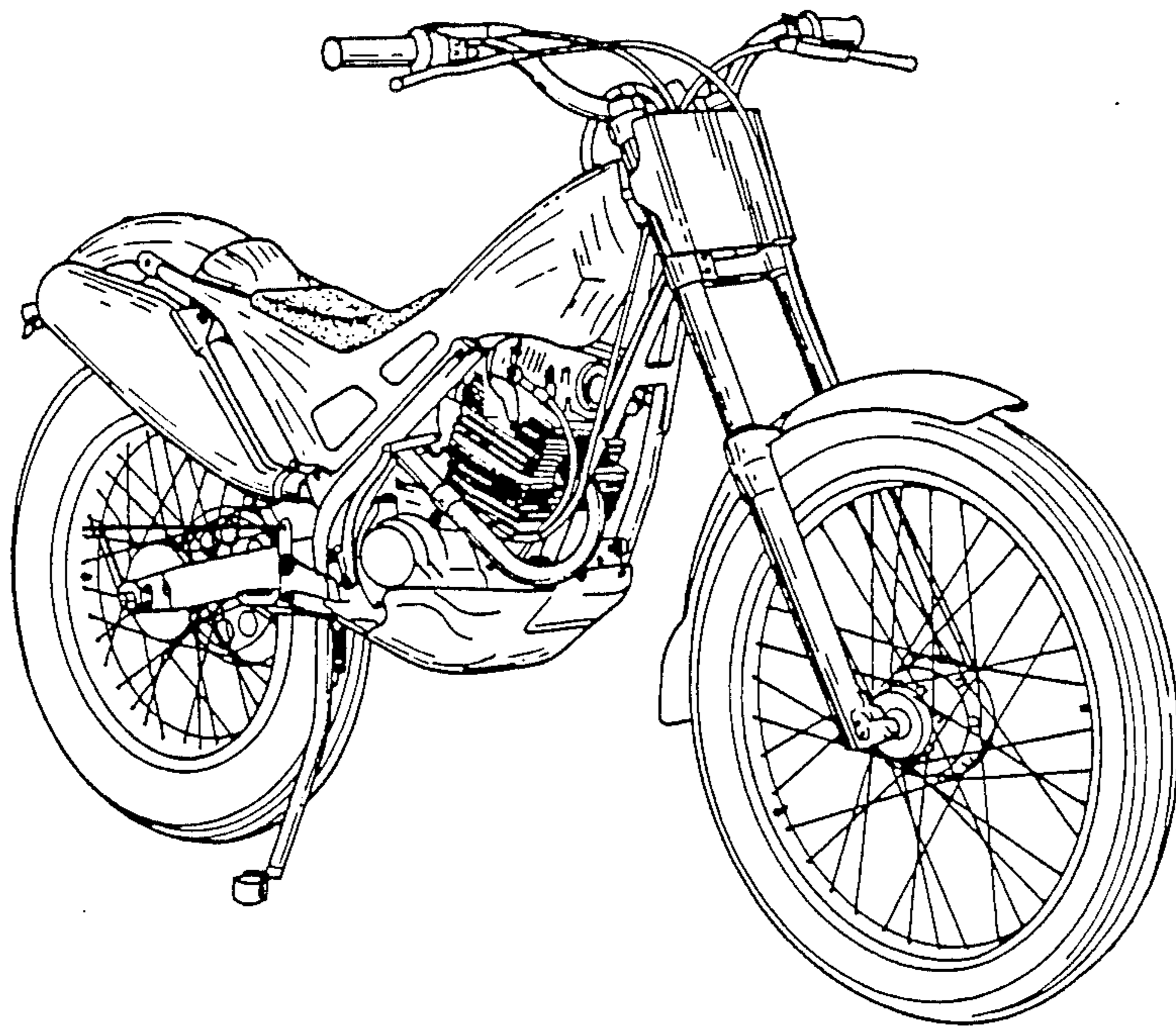

FIG. 6.