

[54] RECONFIGURABLE TOY VEHICLE

[75] Inventor: Hideaki Yoke, Tokyo, Japan

[73] Assignee: Takara Co., Ltd., Tokyo, Japan

[**] Term: 14 Years

[21] Appl. No.: 806,188

[22] Filed: Nov. 22, 1985

[30] Foreign Application Priority Data

Oct. 14, 1985 [JP] Japan 60-42968

[52] U.S. Cl. D21/136; D21/150; 166

[58] Field of Search D21/59, 128, 136, 150, D21/166; 476/71, 72, 73, 74, 75, 77, 78, 383, 381, 487; D12/90

[56] References Cited

U.S. PATENT DOCUMENTS

- D. 253,406 11/1979 Carabetta D12/90
- D. 284,490 7/1986 Ohno D21/150
- D. 284,491 7/1986 Ohno D21/150
- D. 286,169 10/1986 Ohno D21/150
- D. 289,665 5/1987 Nagano D21/150

OTHER PUBLICATIONS

1984 International Playthings Catalog, p. 94, #PG 05/2, Toy Car.

Primary Examiner—Charles A. Rademaker
Attorney, Agent, or Firm—Price, Gess & Ubell

[57] CLAIM

The ornamental design for a reconfigurable toy vehicle, substantially as shown and described.

DESCRIPTION

FIG. 1 is a front perspective view of a reconfigurable toy vehicle, showing my new design;
 FIG. 2 is a front elevational view thereof;
 FIG. 3 is a right side elevational view thereof, the side opposite being substantially a mirror image;
 FIG. 4 is a rear elevational view thereof;
 FIG. 5 is a top plan view thereof;
 FIG. 6 is a bottom plan view thereof;
 FIG. 7 is a front perspective view of the design shown in FIGS. 1 through 6 reconfigured in a robotic humanoid configuration;
 FIG. 8 is a front elevational view thereof;
 FIG. 9 is a right side elevational view thereof, the side opposite being substantially a mirror image;
 FIG. 10 is a rear elevational view thereof;
 FIG. 11 is a top plan view thereof; and,
 FIG. 12 is a bottom plan view thereof.

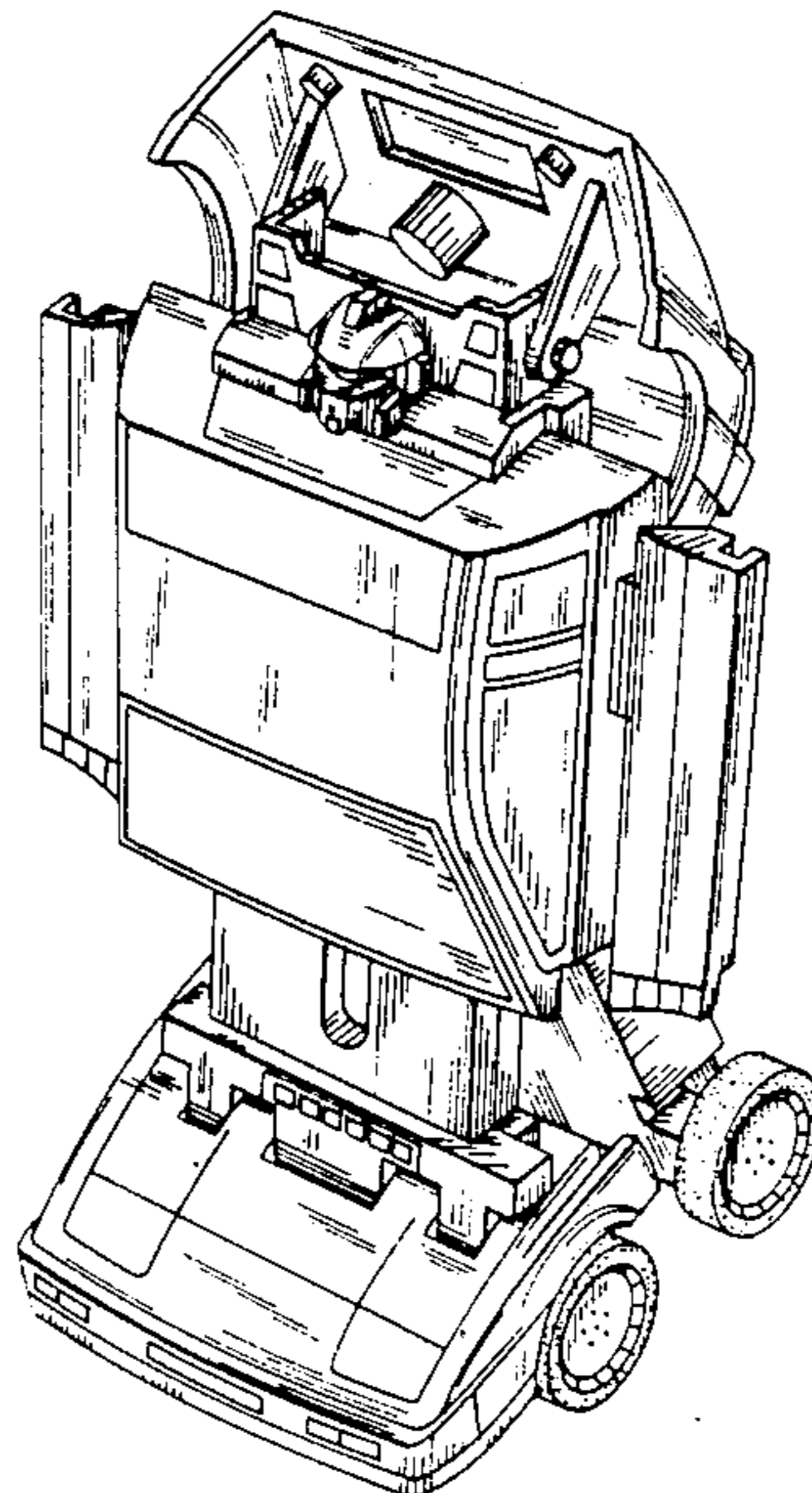
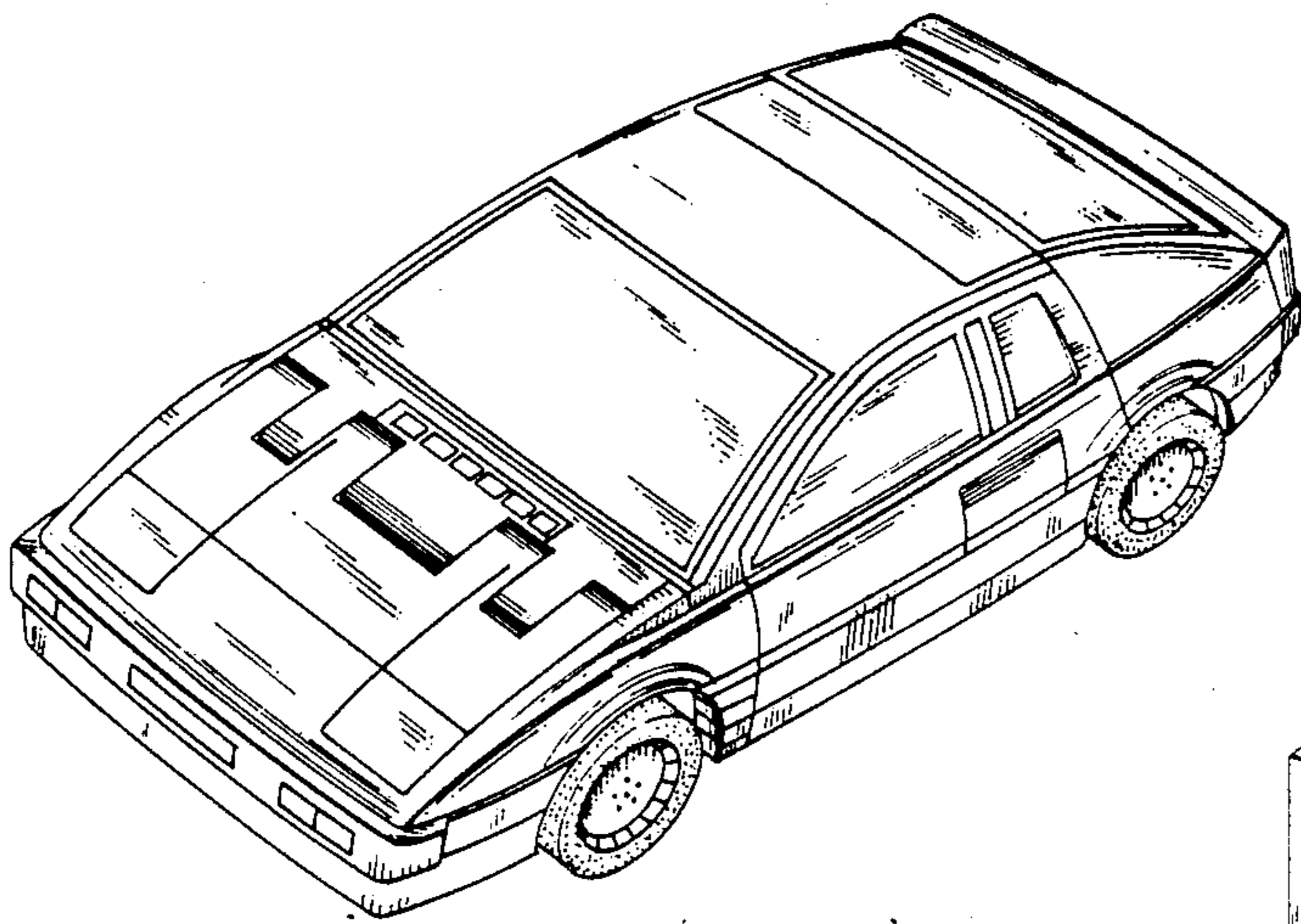

FIG. 2

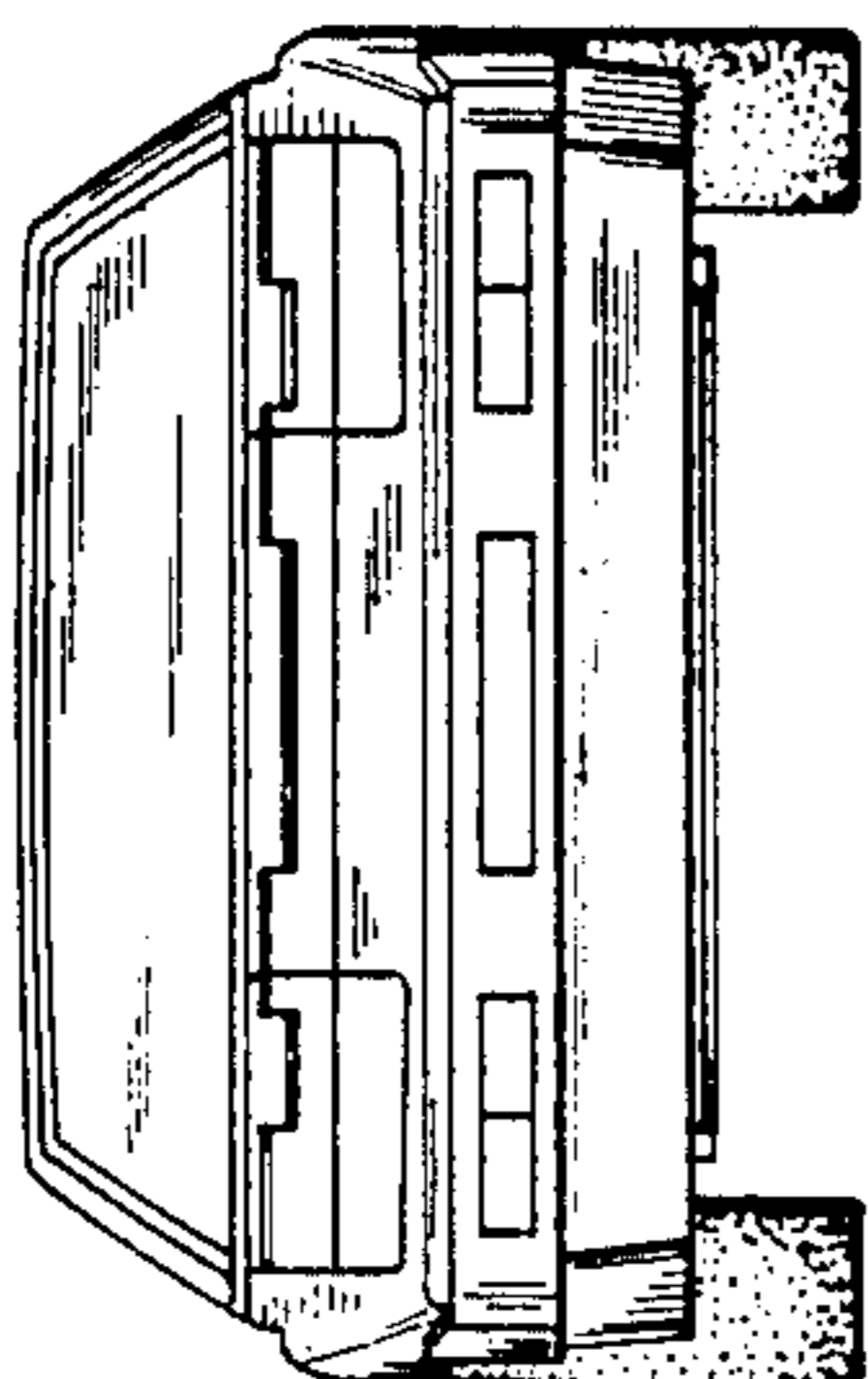

FIG. 3

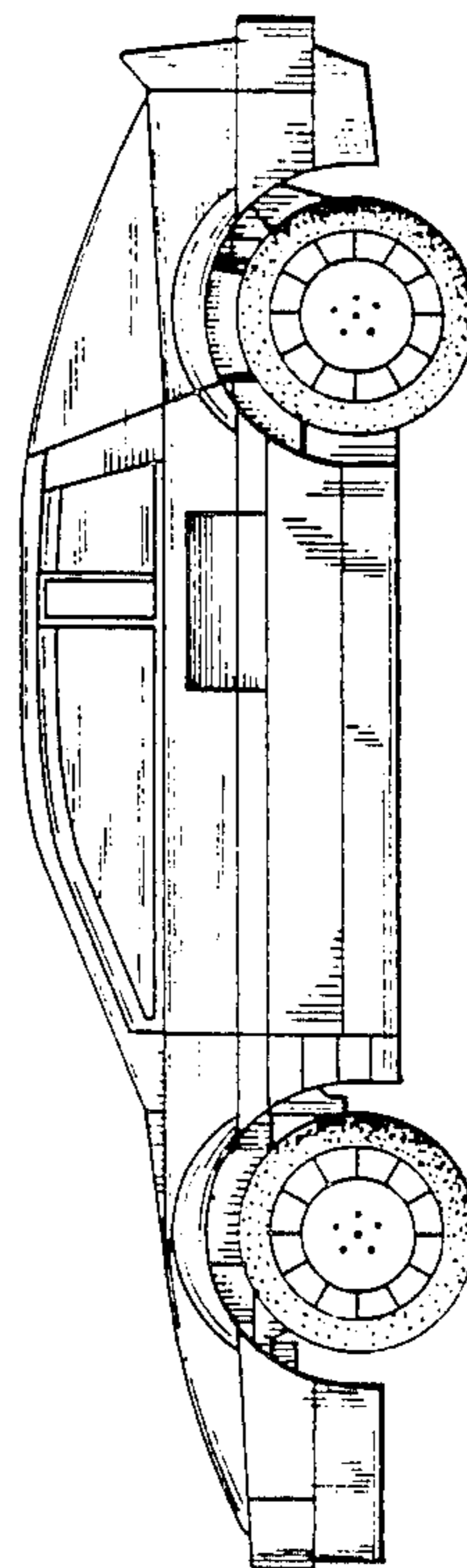

FIG. 1

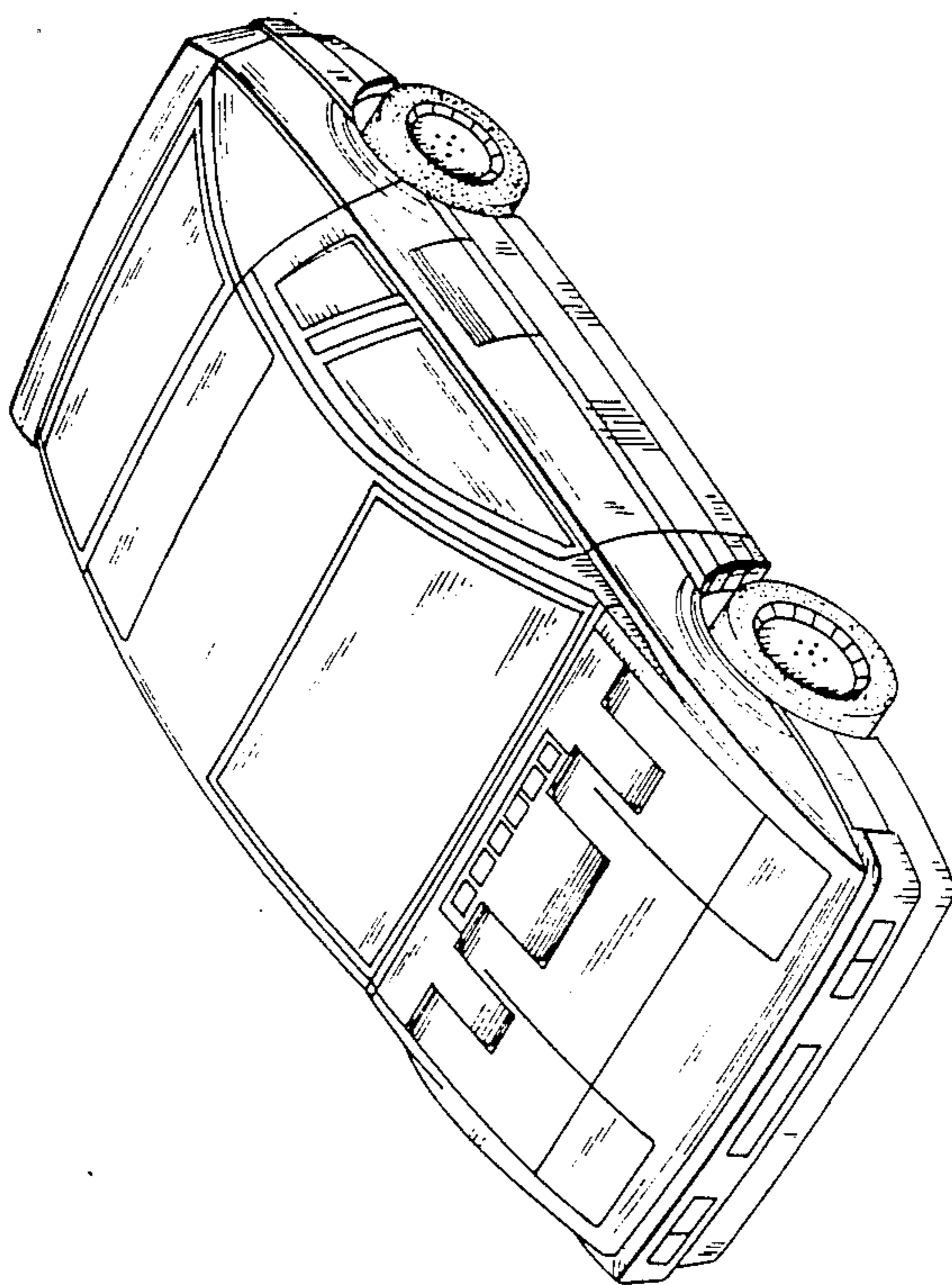

FIG. 4

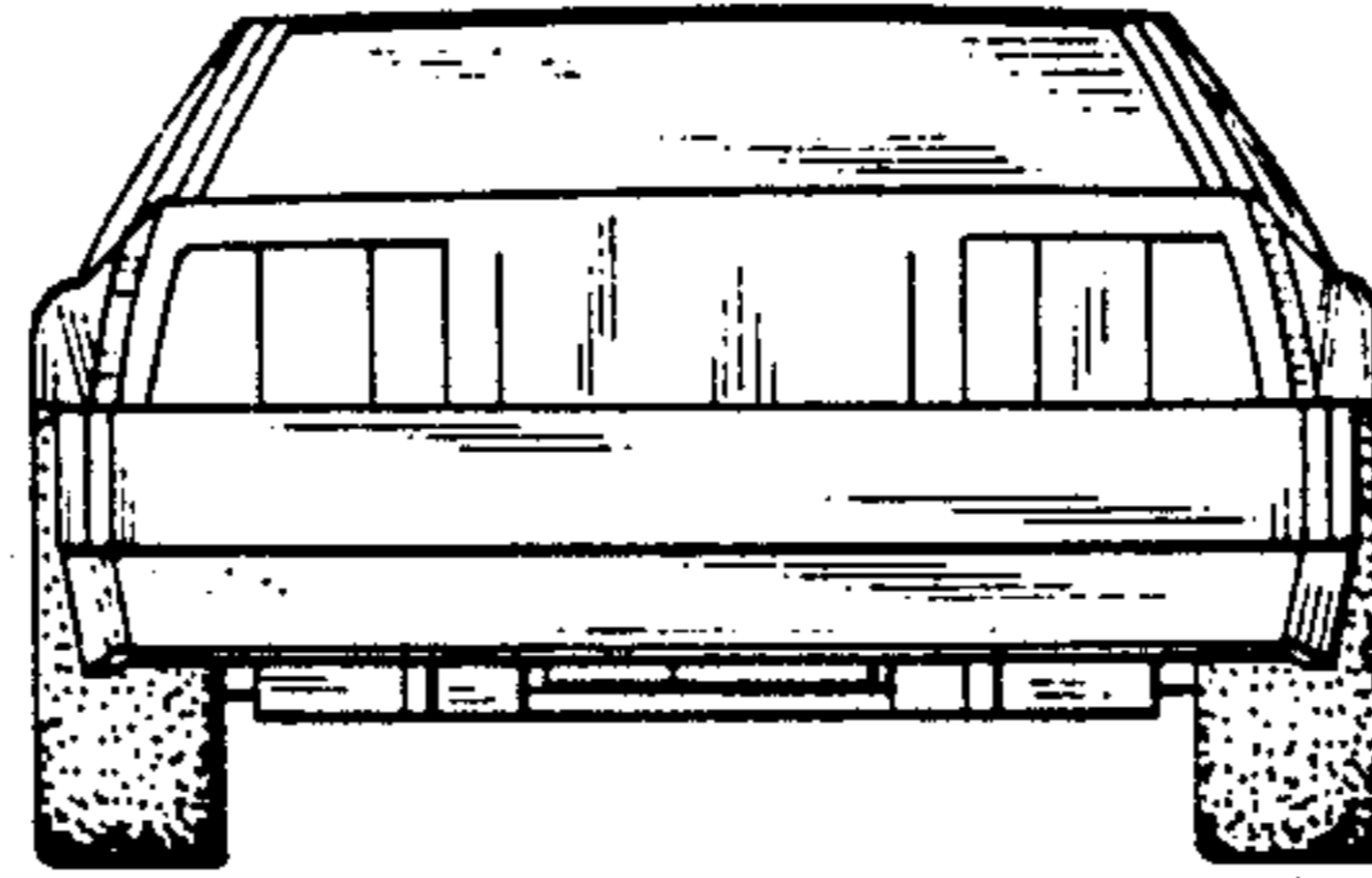

FIG. 5

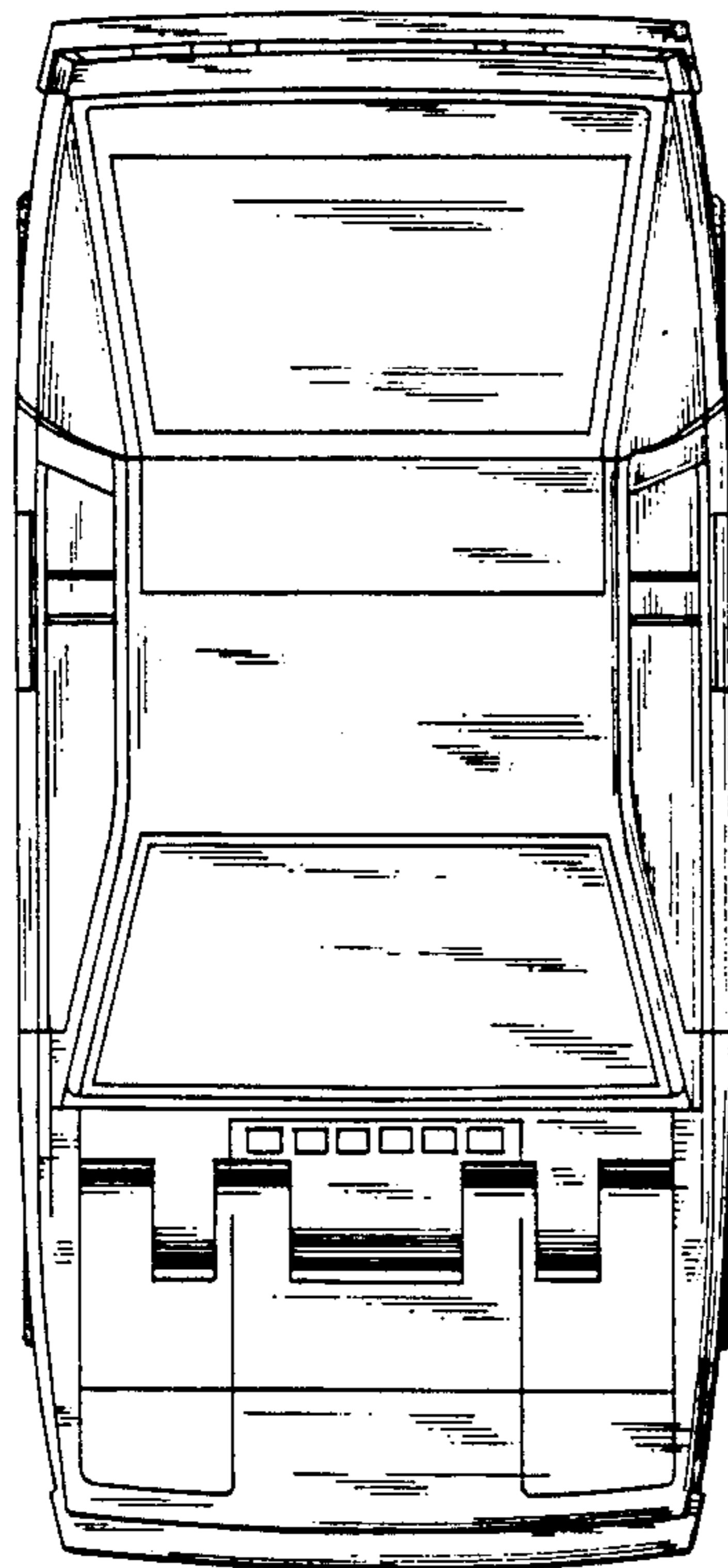

FIG. 6

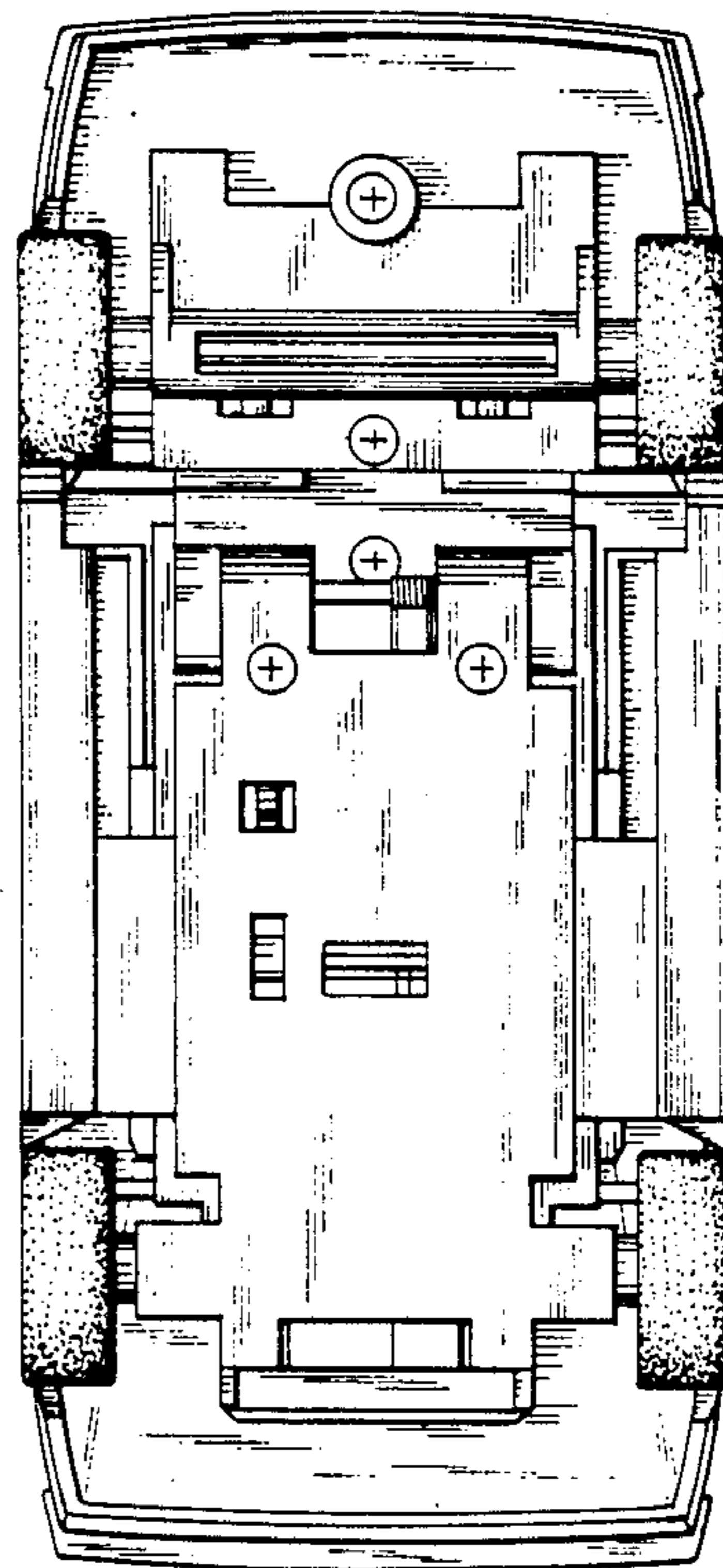

FIG. 8

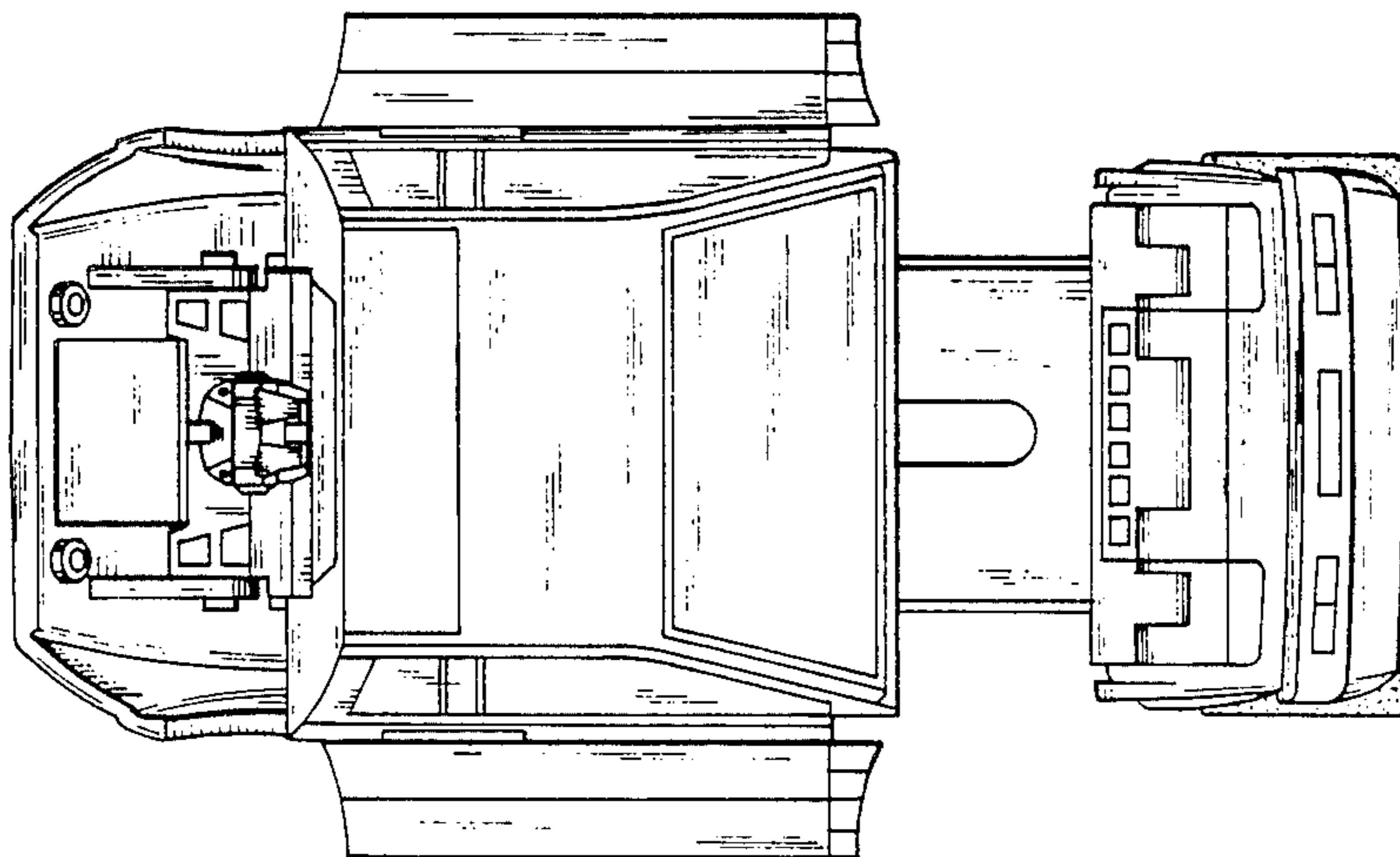

FIG. 7

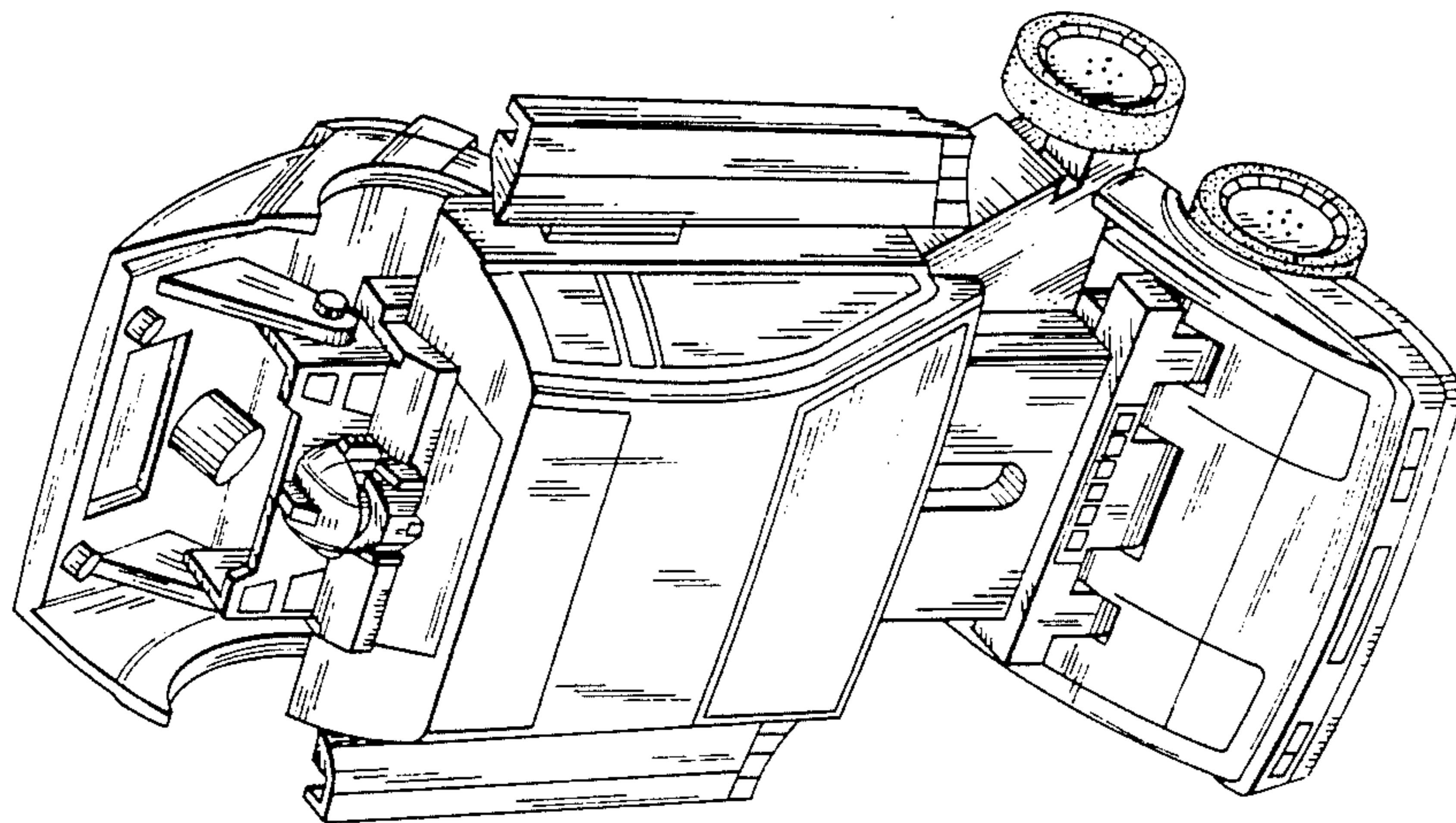

FIG.10

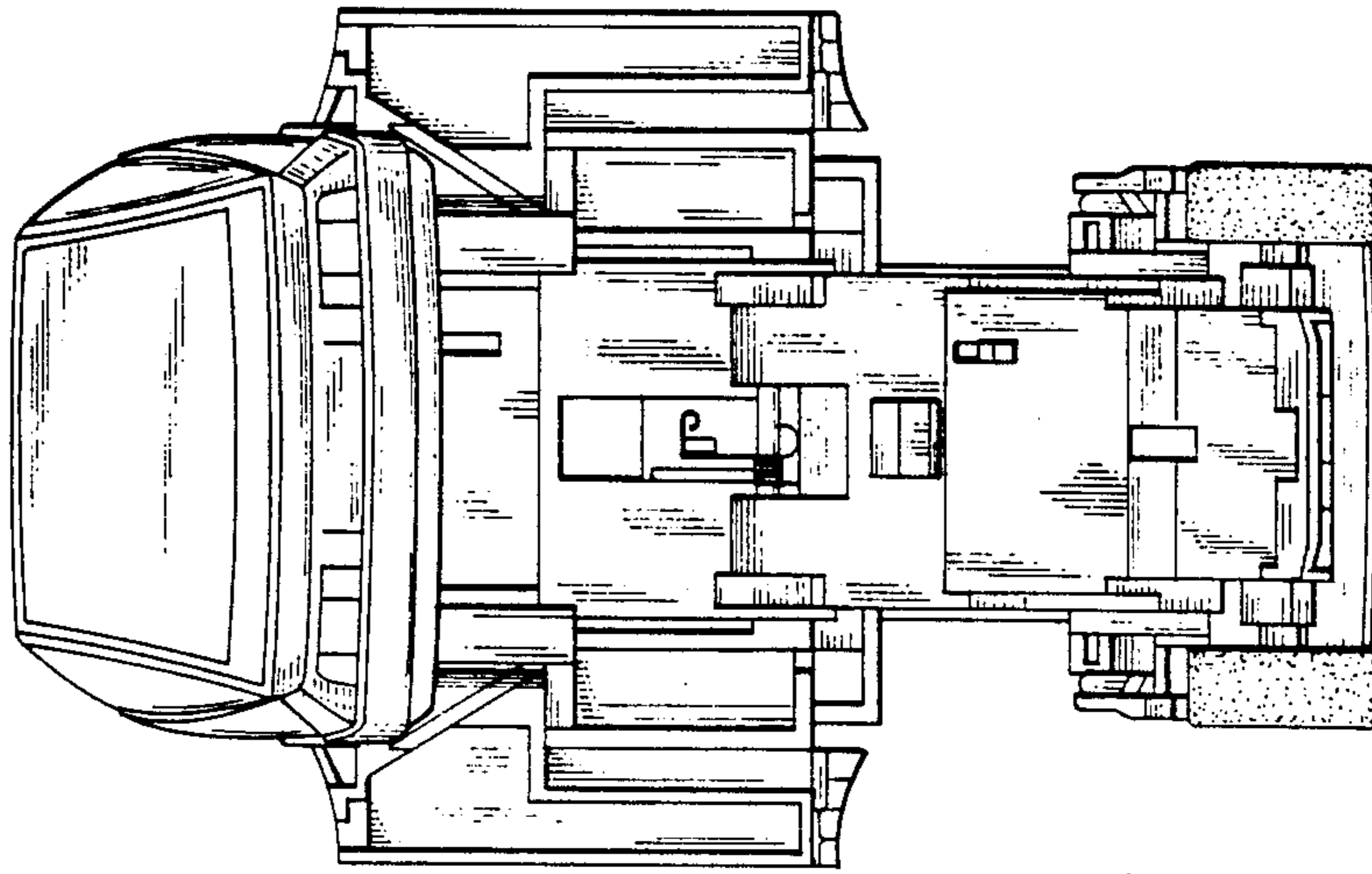

FIG. 9

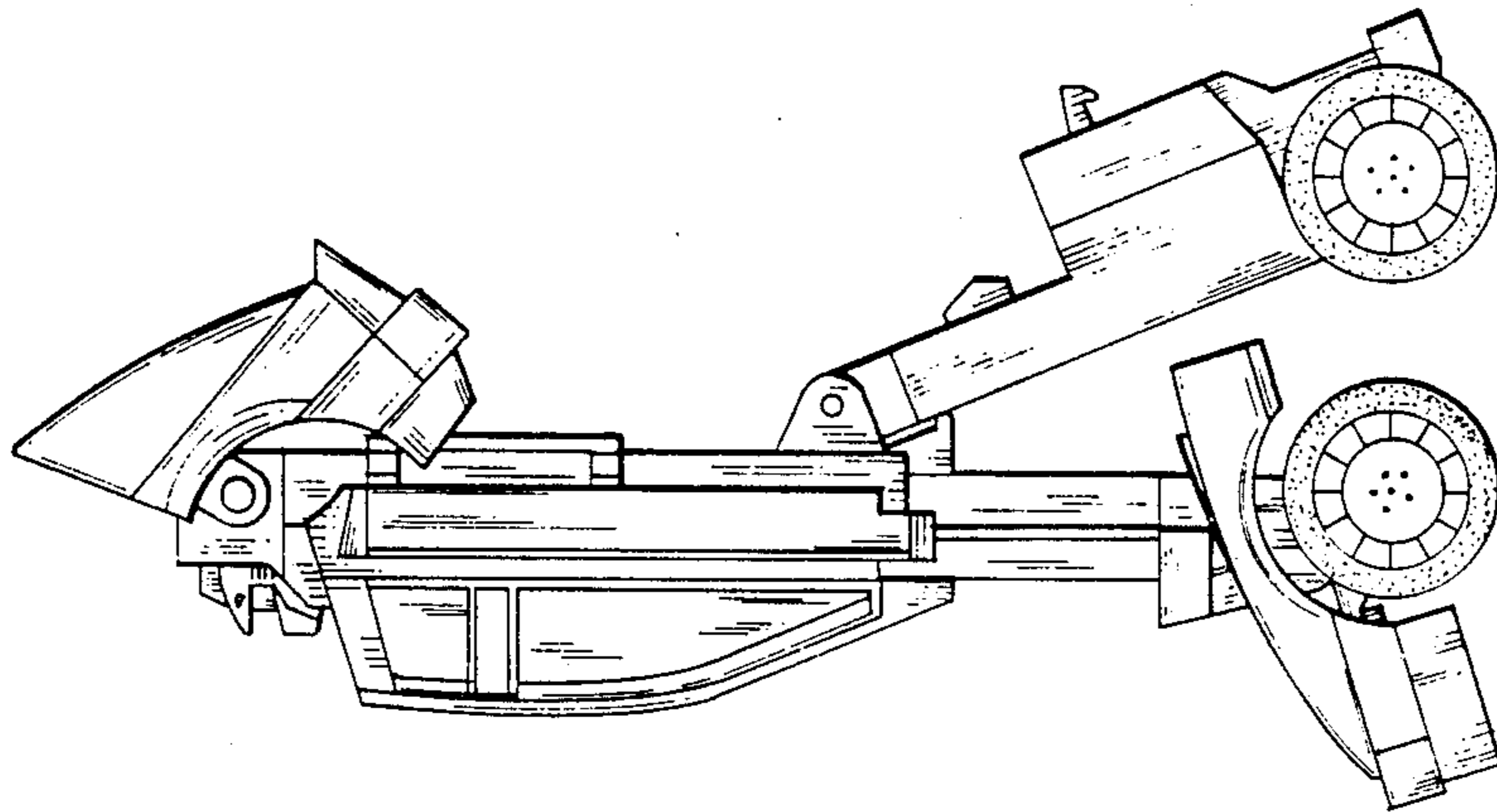

FIG.11

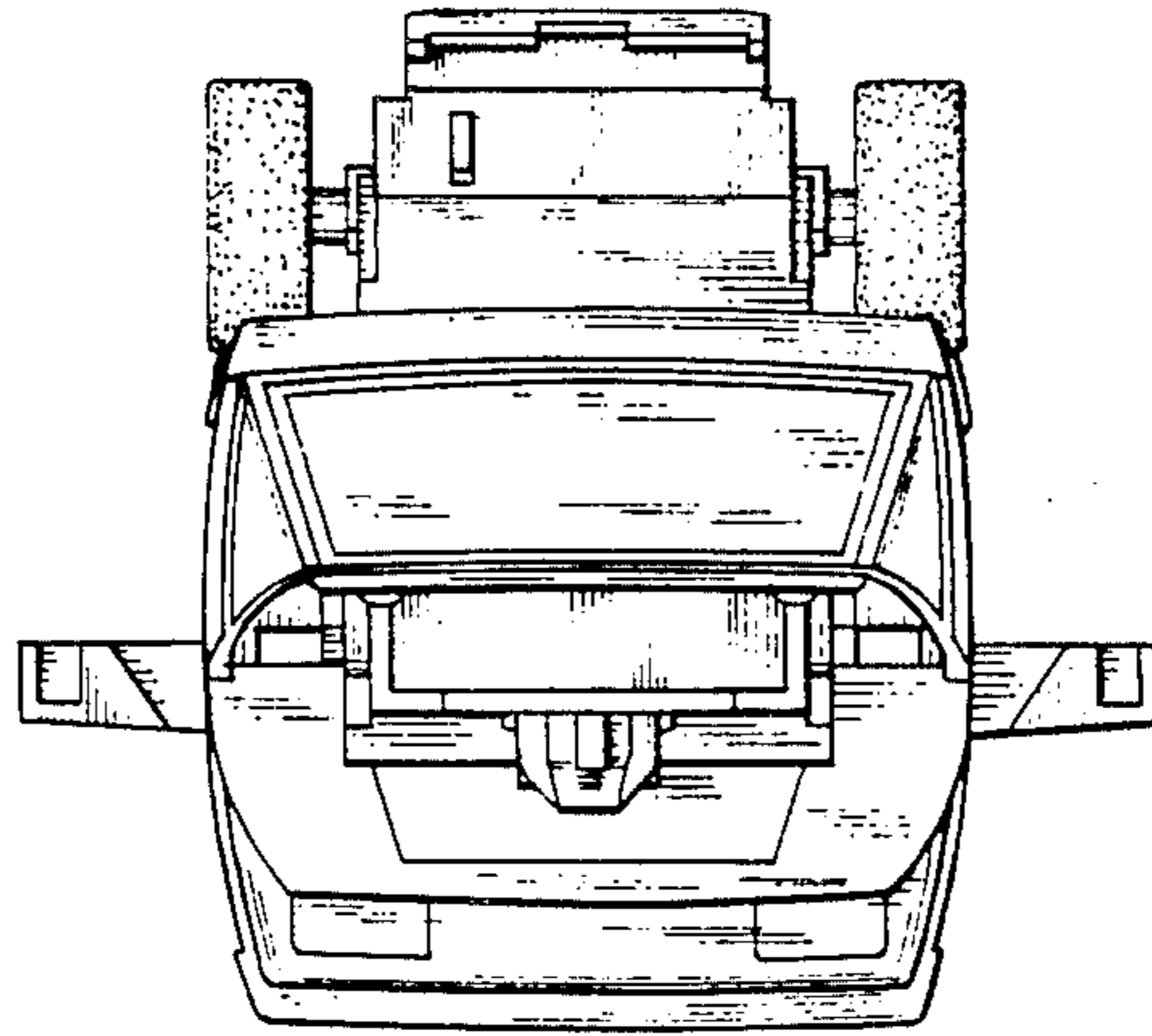

FIG.12

