

United States Patent [19]

Ohno et al.

[11] Patent Number: Des. 295,060

[45] Date of Patent: ** Apr. 5, 1988

[54] ASSEMBLED HUMANOID ROBOT TOY

[75] Inventors: Kouzin Ohno; Kaoru Matsumoto,
both of Tokyo, Japan

[73] Assignee: Takara Co., Ltd., Tokyo, Japan

[**] Term: 14 Years

[21] Appl. No.: 768,515

[22] Filed: Aug. 22, 1985

[30] Foreign Application Priority Data

May 13, 1985 [JP] Japan 60-19640
[52] U.S. Cl. D21/150
[58] Field of Search D21/150, 87; 446/376,
446/487, 99, 100, 71-75

[56]

References Cited

U.S. PATENT DOCUMENTS

D. 279,804 7/1985 Ohno D21/150
D. 281,090 10/1985 Murakami D21/150
D. 287,378 12/1986 Ohno D21/150

Primary Examiner—Melvin B. Feifer
Attorney, Agent, or Firm—Price, Gess & Ubell

[57]

CLAIM

The ornamental design for an assembled humanoid robot toy, substantially as shown and described.

DESCRIPTION

FIG. 1 is a front side perspective view of the assembled humanoid robot toy showing our new design; FIG. 2 is a front elevational view thereof; FIG. 3 is a right elevational side view thereof; FIG. 4 is a left elevational side view thereof; FIG. 5 is a rear elevational view thereof; FIG. 6 is a top plan view thereof; and FIG. 7 is a bottom plan view thereof.

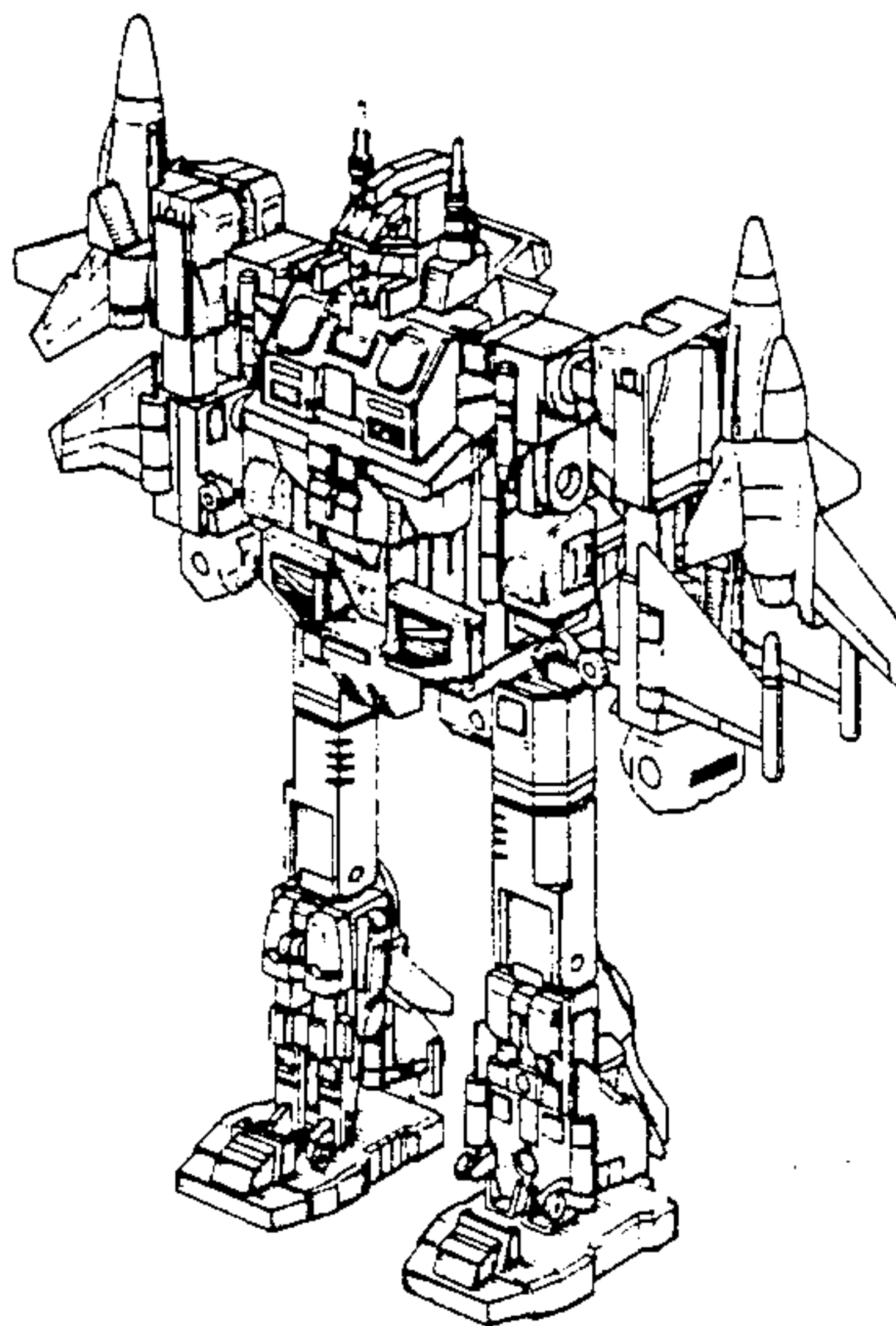

FIG. 1

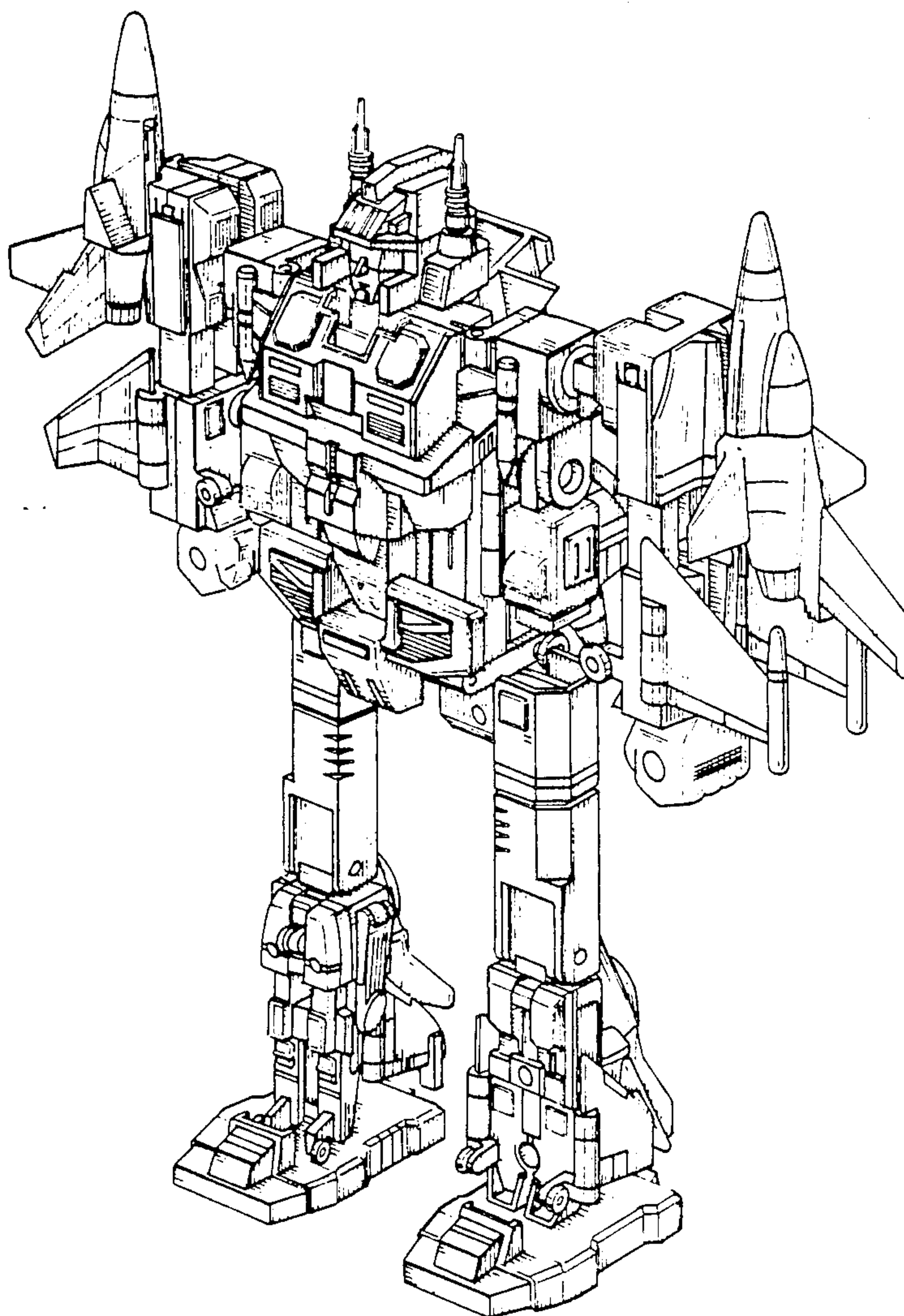

FIG. 3

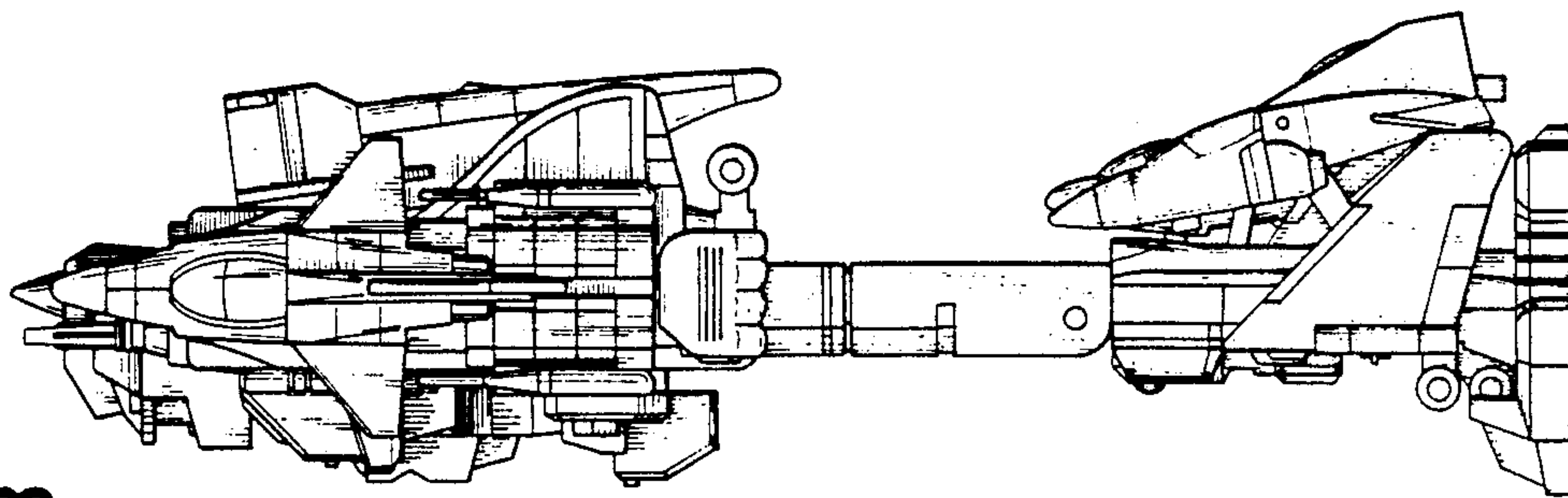
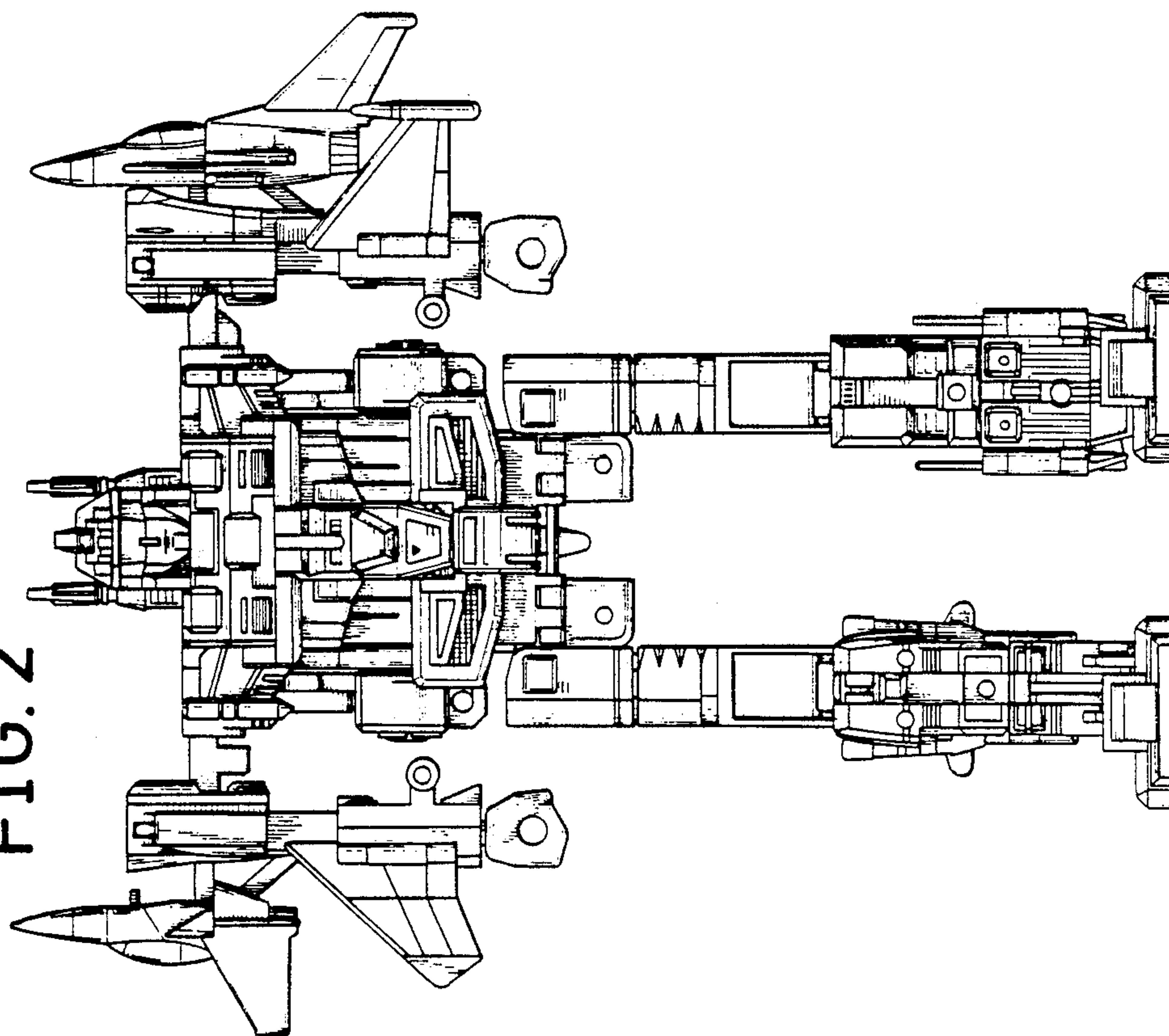

FIG. 2



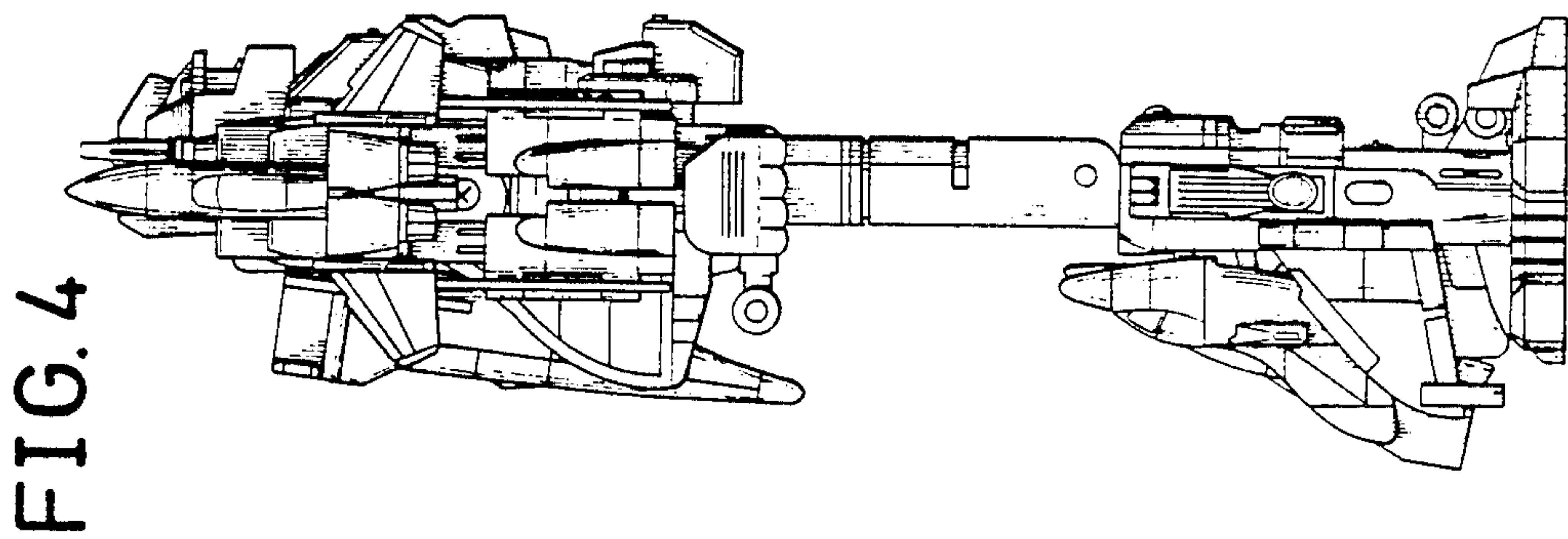
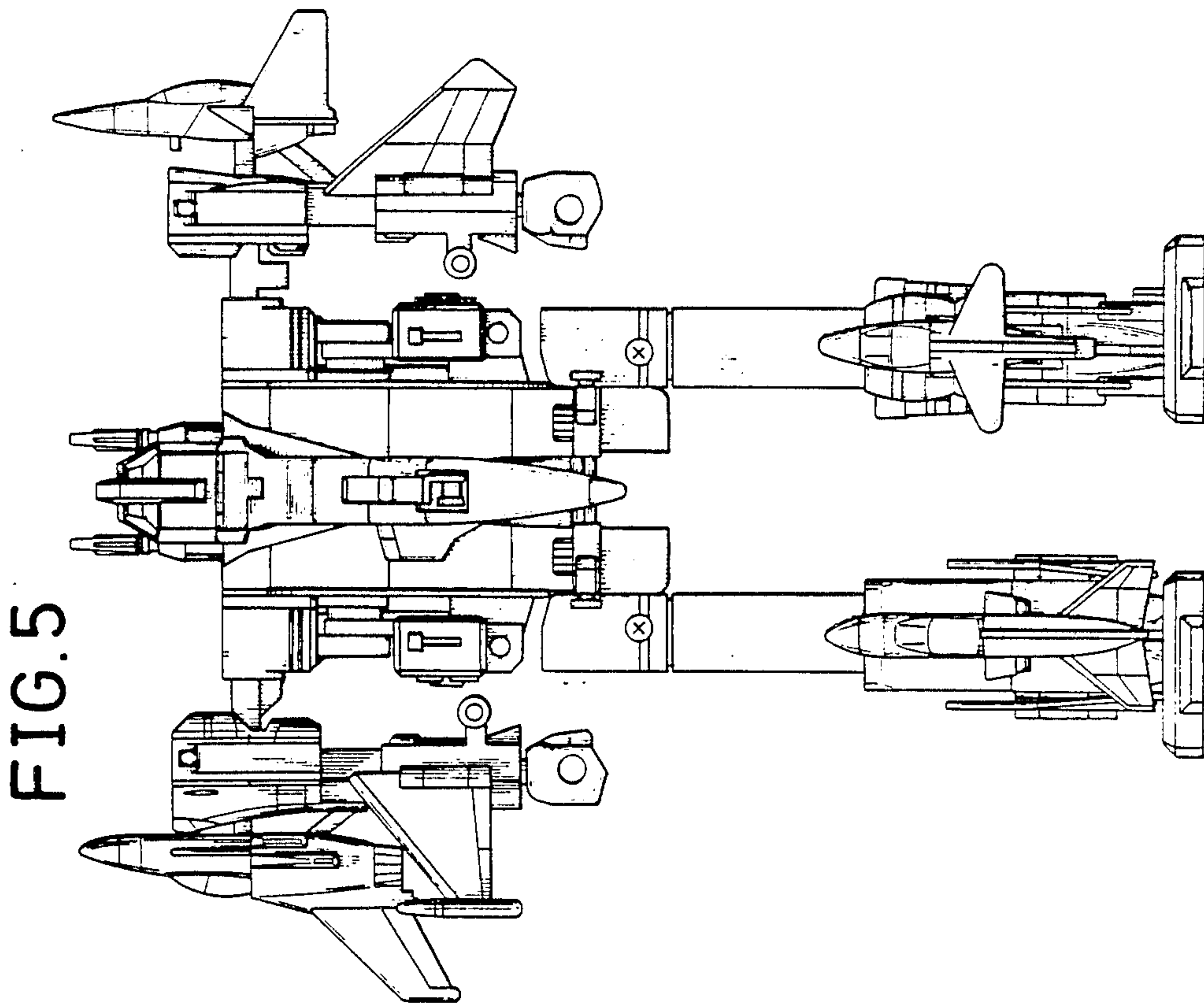

FIG. 6

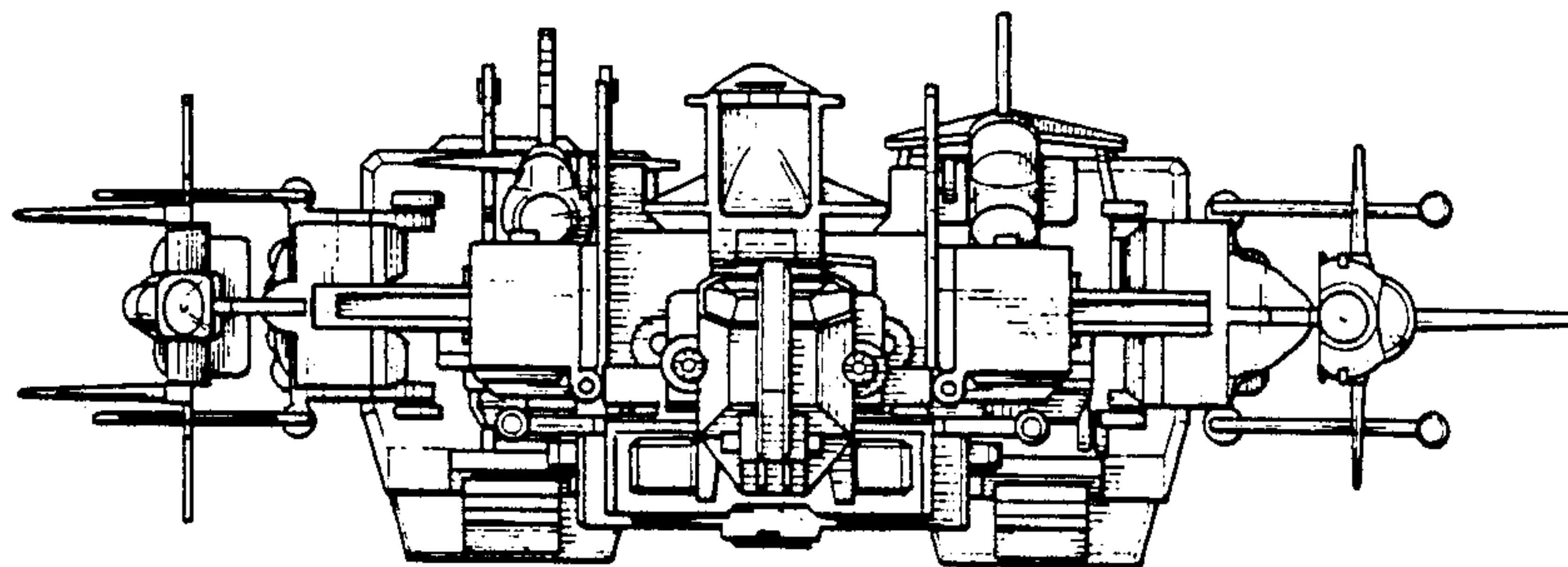

FIG. 7

