

[54] MOTORCYCLE

[75] Inventors: **Hirotohi Kizawa**, Tokyo; **Michio Tashiro**, Saitama, both of Japan

[73] Assignee: **Honda Giken Kogyo Kabushiki Kaisha**, Tokyo, Japan

[**] Term: **14 Years**

[21] Appl. No.: **780,560**

[22] Filed: **Sep. 26, 1985**

[30] Foreign Application Priority Data

Apr. 9, 1985 [JP] Japan 60-14400

[52] U.S. Cl. **D12/110**

[58] Field of Search **D12/110; 180/219**

[56] References Cited

U.S. PATENT DOCUMENTS

D. 267,638 1/1983 Iwasaki D12/110

D. 274,421 6/1984 Iwakura et al. D12/110

OTHER PUBLICATIONS

Cycle World, 2/84, p. 20, Harley-Davidson motorcycle, bottom left side of page.

Cycle World, 12/84, p. 32, Honda CMZ250 C rebel, upper right side of page.

Primary Examiner—James M. Gandy
Attorney, Agent, or Firm—Lyon & Lyon

[57] CLAIM

The ornamental design for a motorcycle, as shown.

DESCRIPTION

FIG. 1 is a top plan view of a motorcycle showing our new design;

FIG. 2 is a front perspective view thereof;

FIG. 3 is a side elevation view of the right side thereof;

FIG. 4 is a side elevation view of the left side thereof;

FIG. 5 is a back perspective view thereof;

FIG. 6 is an oblique perspective view principally illustrating the right side thereof.

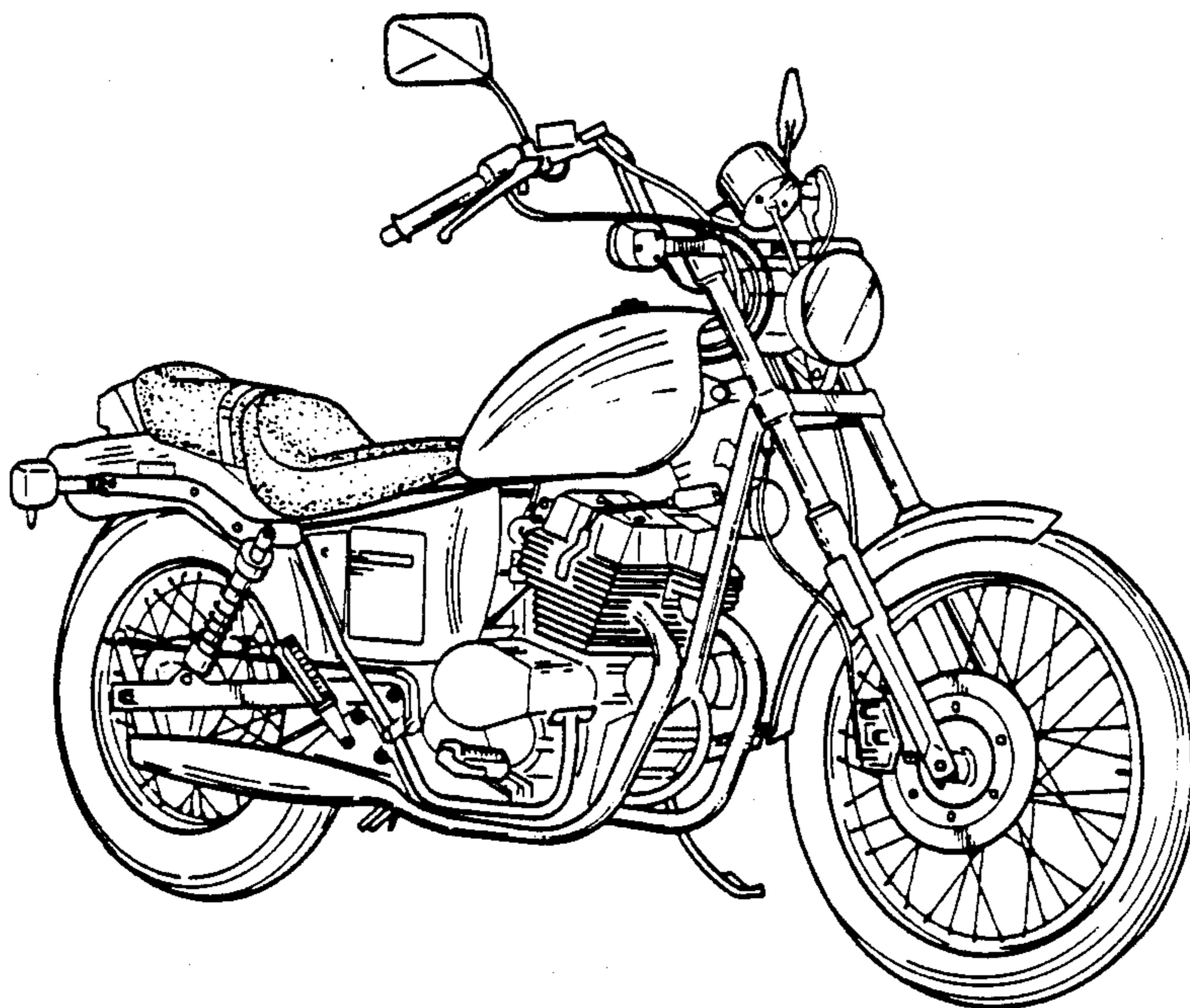

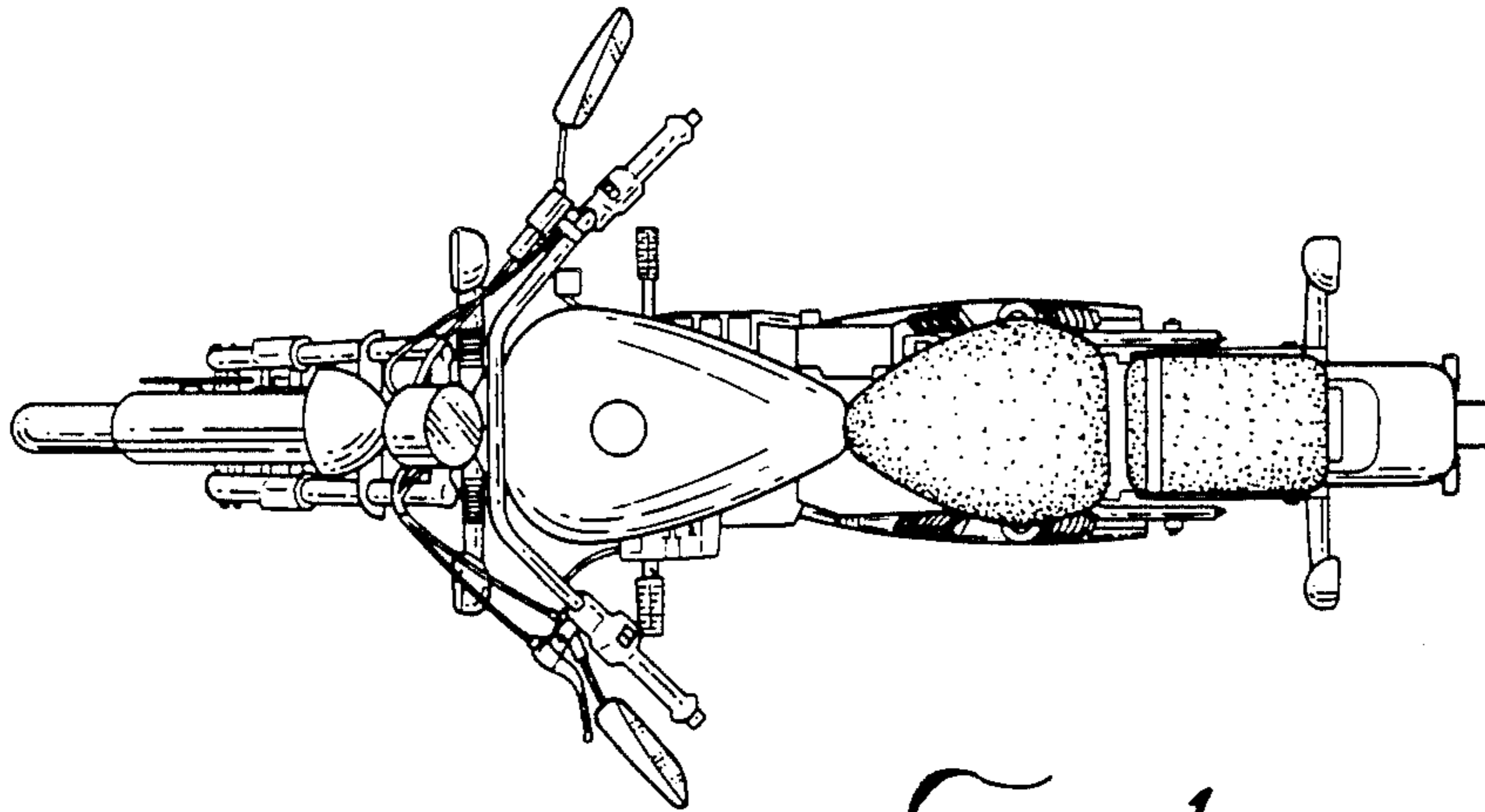
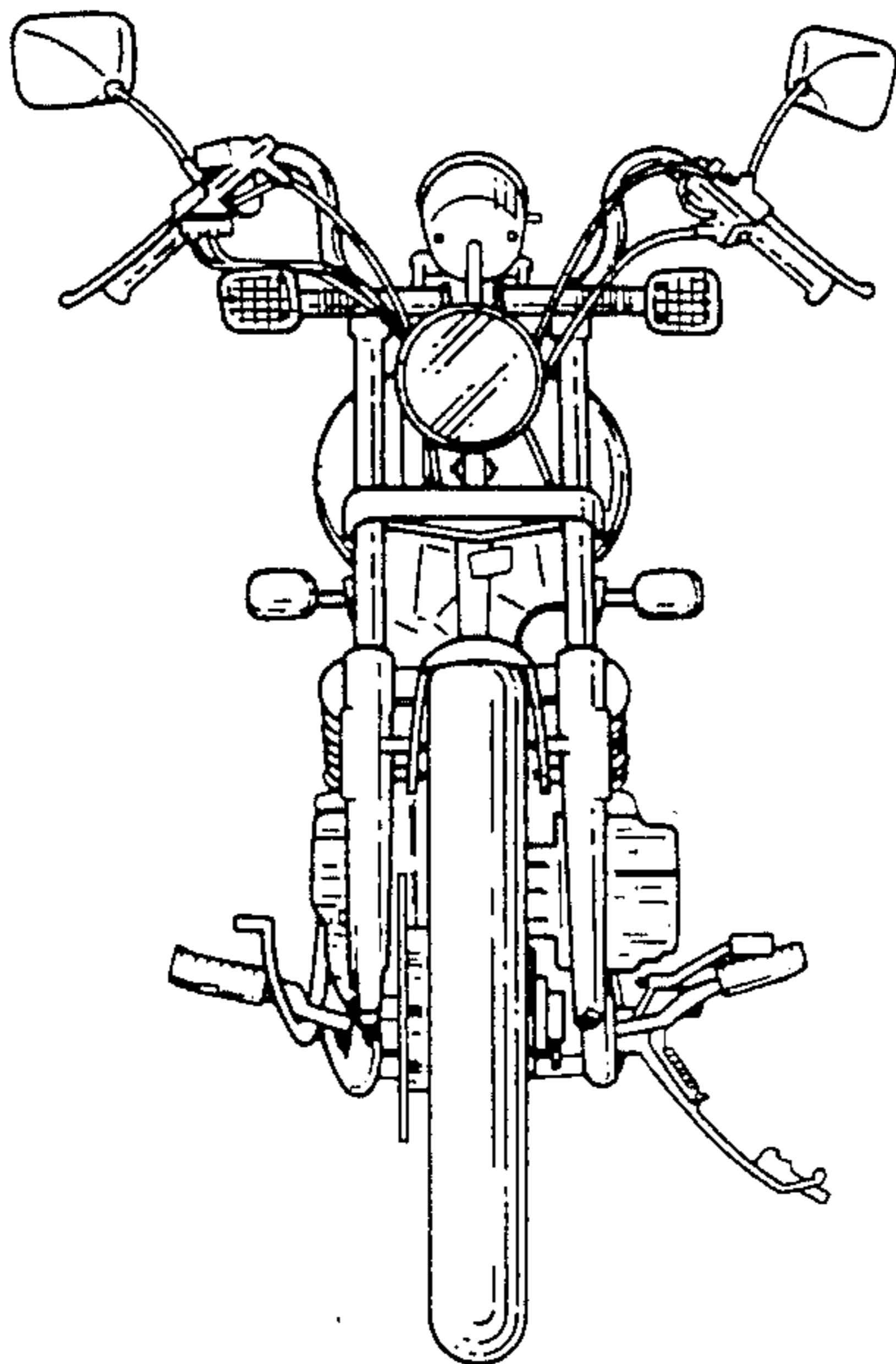

FIG. 1.

FIG. 2.



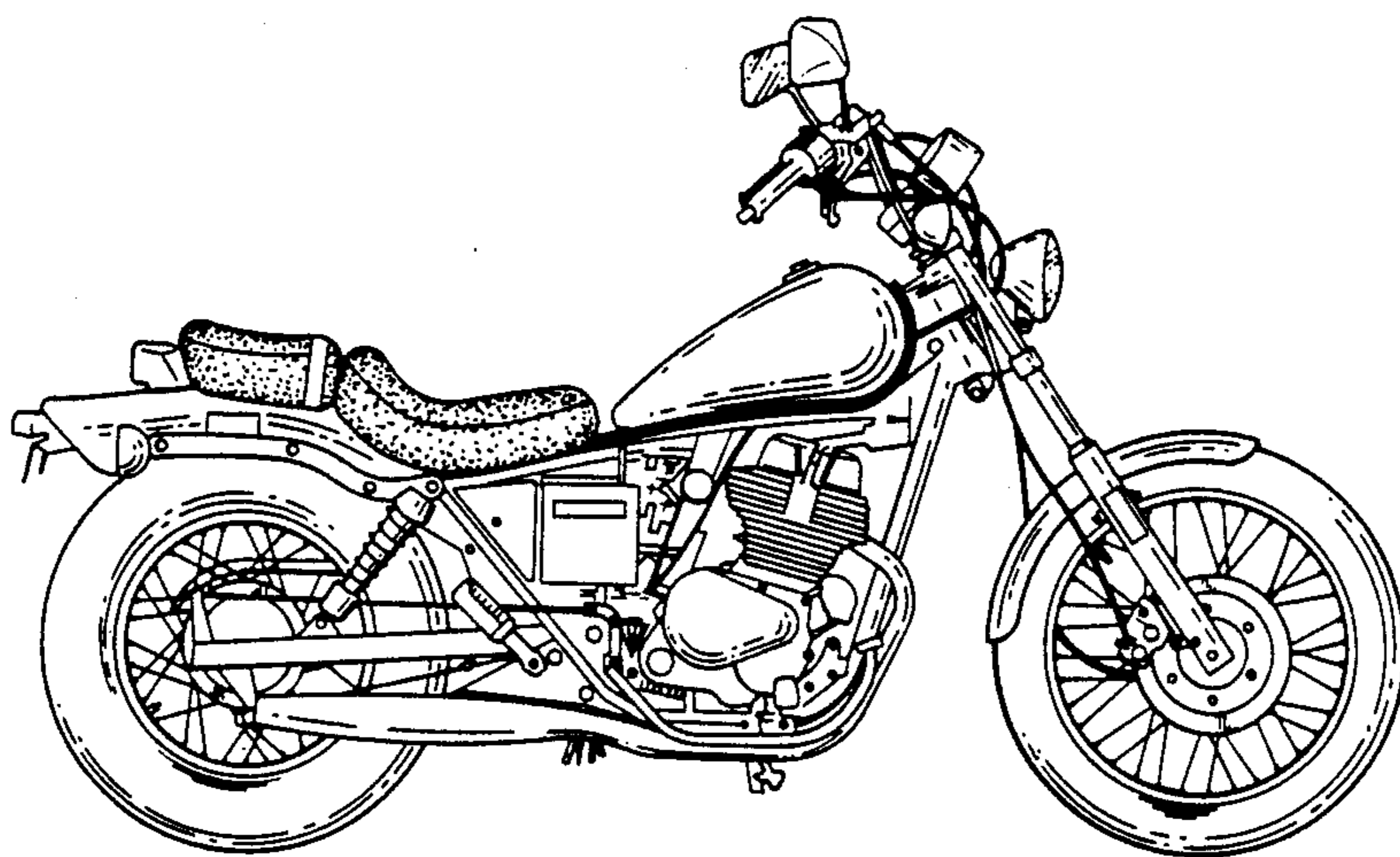

FIG. 3.

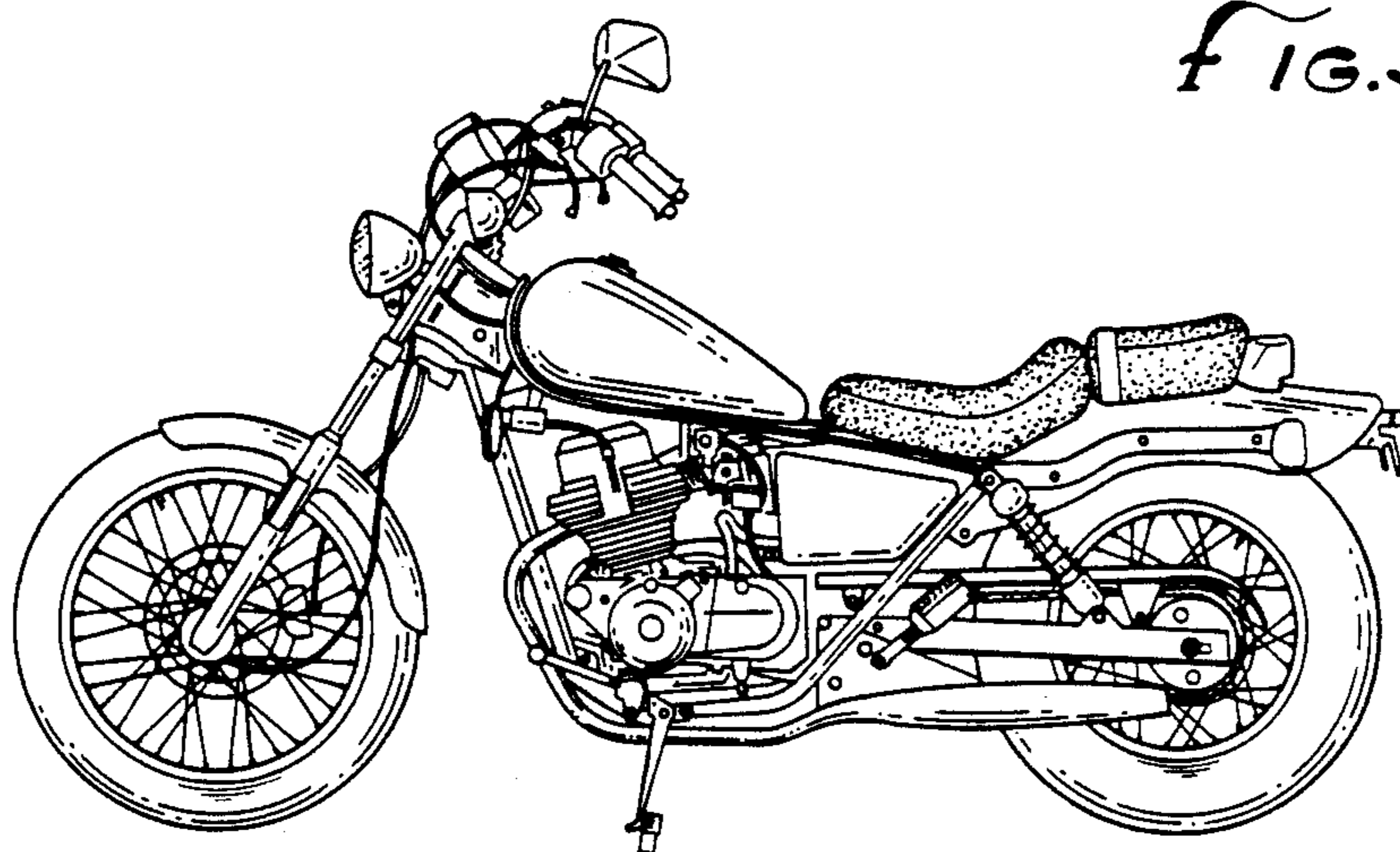

FIG. 4.

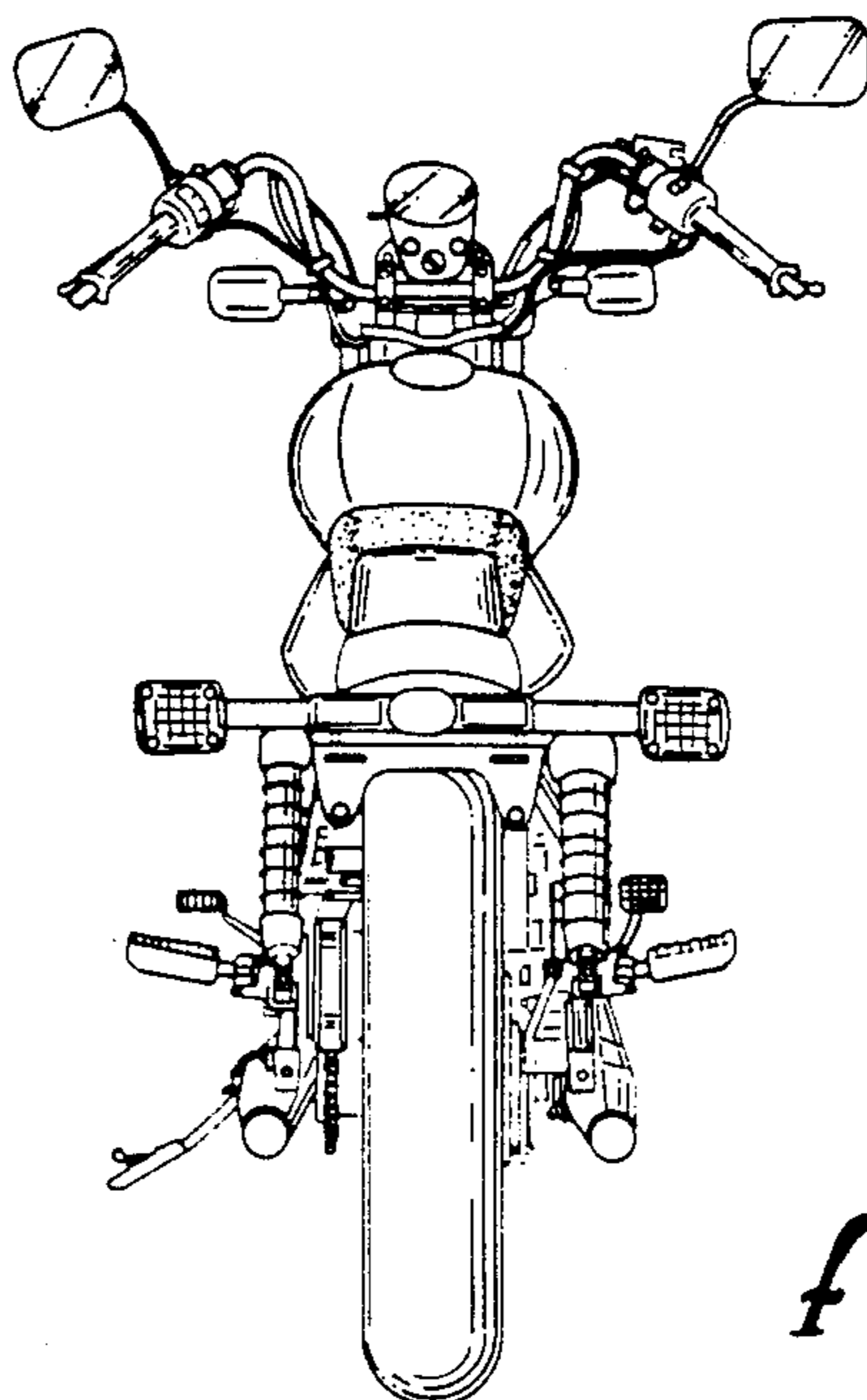

FIG. 5.

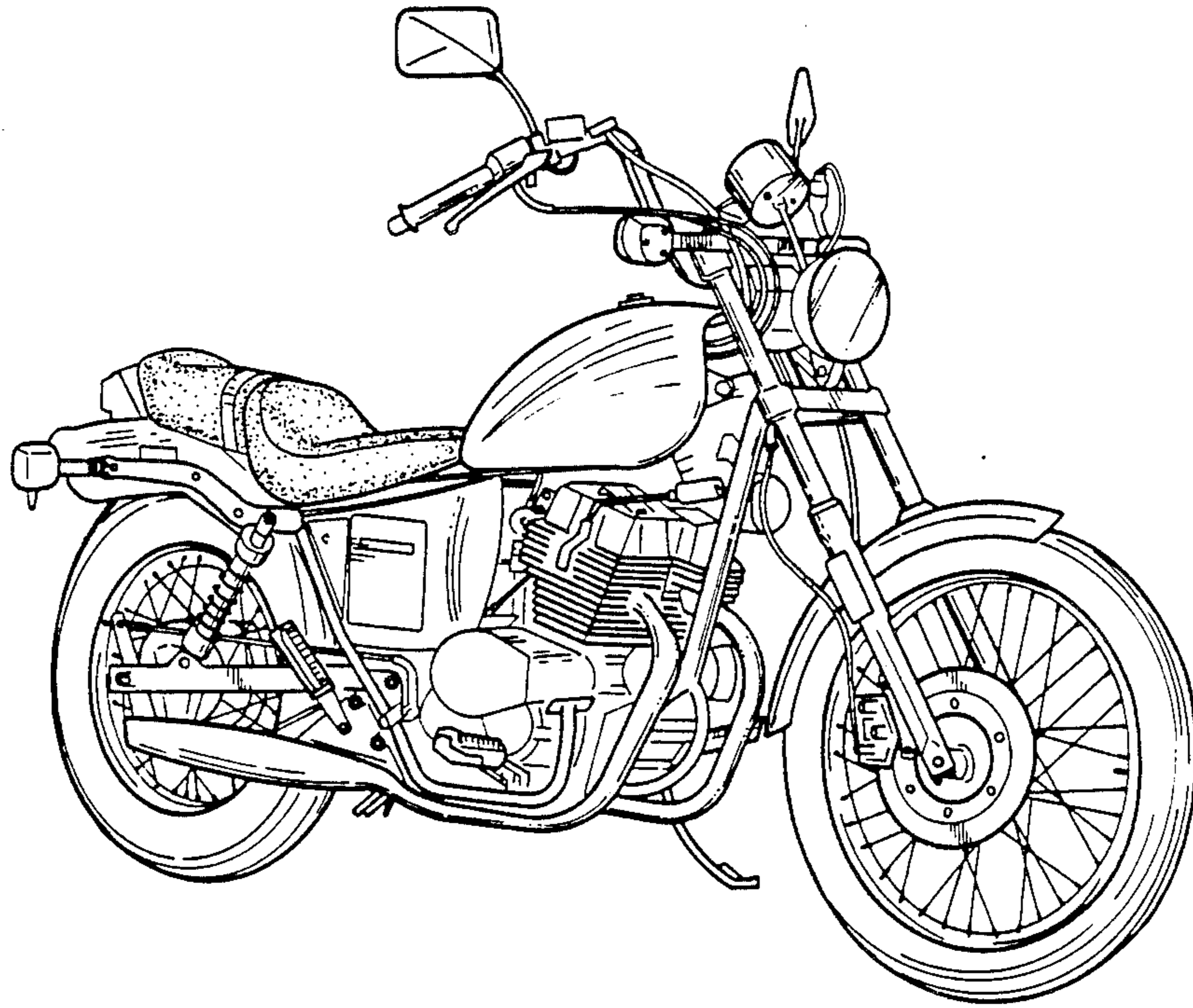

FIG. 6.