

[54] TRAFFIC CONE

3,922,998 12/1975 May 116/63 P
4,292,627 9/1981 Knight 116/63 C X

[76] Inventor: Yang-Ming Lin, No. 276, Chung Cheng S. Rd., Yung kang Hsiang, Tainan Hsien, Taiwan

FOREIGN PATENT DOCUMENTS

[**] Term: 14 Years

1136250 9/1962 Fed. Rep. of Germany 116/63 P
2415691 9/1979 France 116/63 P
1078785 8/1967 United Kingdom 116/63 P
2090313 7/1982 United Kingdom 116/63 C
2096214 10/1982 United Kingdom 116/63 C
1022063 9/1984 United Kingdom .

[21] Appl. No.: 740,987

[22] Filed: Jun. 4, 1985

Related U.S. Application Data

Primary Examiner—Catherine E. Kemper
Attorney, Agent, or Firm—Knobbe, Martens, Olson & Bear

[63] Continuation-in-part of Ser. No. 647,612, Sep. 5, 1984.

[52] U.S. Cl. D10/113

[57] CLAIM

[58] Field of Search 116/63 R, 63 P, 63 C;
D10/113; 40/612; 404/6-16

The ornamental design for a traffic cone, as shown and described.

[56] References Cited

DESCRIPTION

U.S. PATENT DOCUMENTS

2,333,273 11/1943 Scanlon 116/63 C
2,957,444 10/1960 Boettler 116/63 C
3,247,823 4/1966 Buck et al. 116/63 C
3,596,628 8/1971 Wright 116/63 C
3,618,556 11/1971 Dittrich 116/63 C
3,696,237 10/1972 Whitehead 116/63 C
3,707,320 12/1972 Brynes 116/63 C

FIG. 1 is a perspective view of a traffic cone showing my new design;
FIG. 2 is a front elevational view thereof;
FIG. 3 is a rear elevational view thereof;
FIG. 4 is a left side elevational view thereof;
FIG. 5 is a right side elevational view thereof;
FIG. 6 is a top plan view thereof; and
FIG. 7 is a bottom plan view thereof.

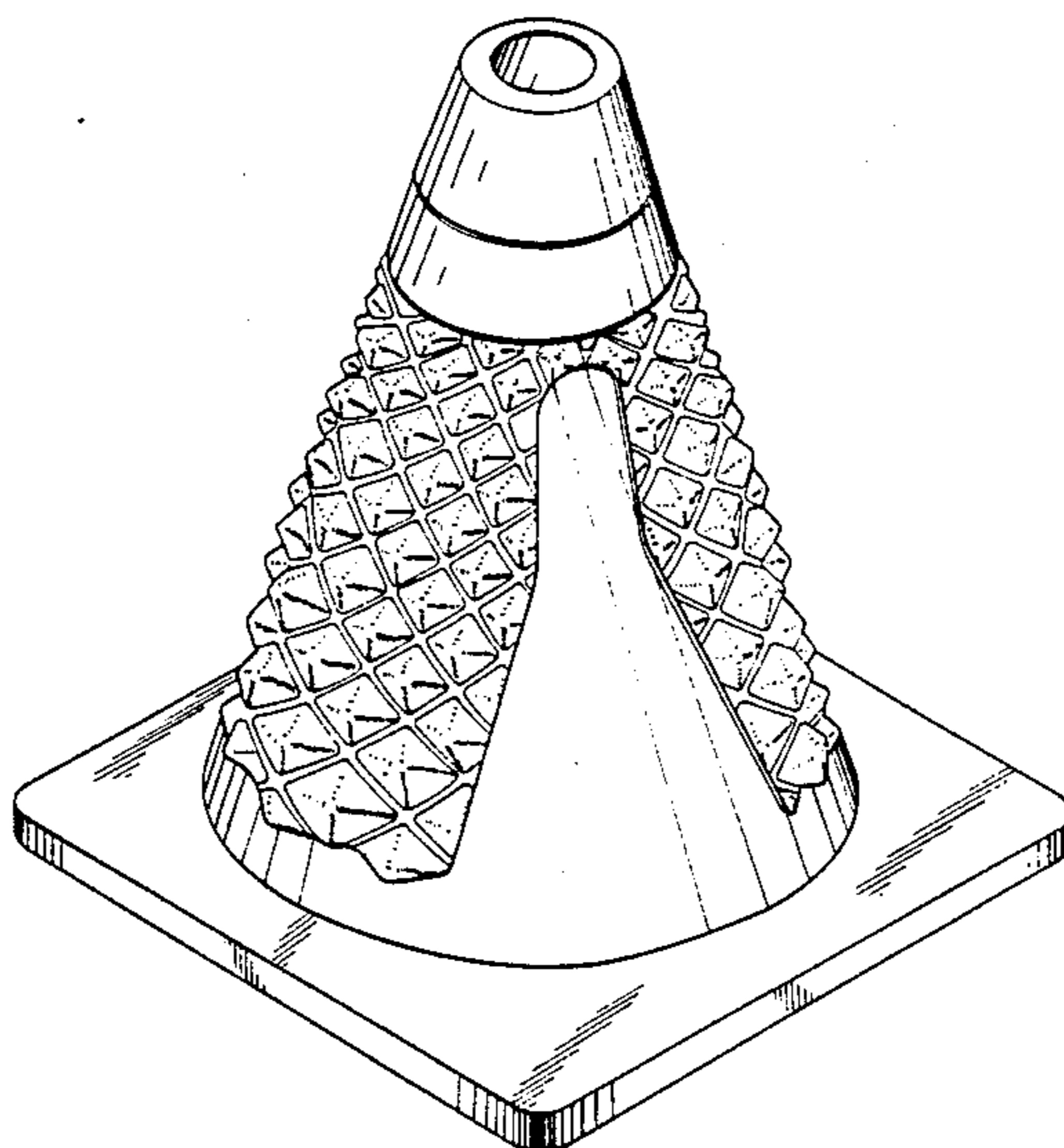

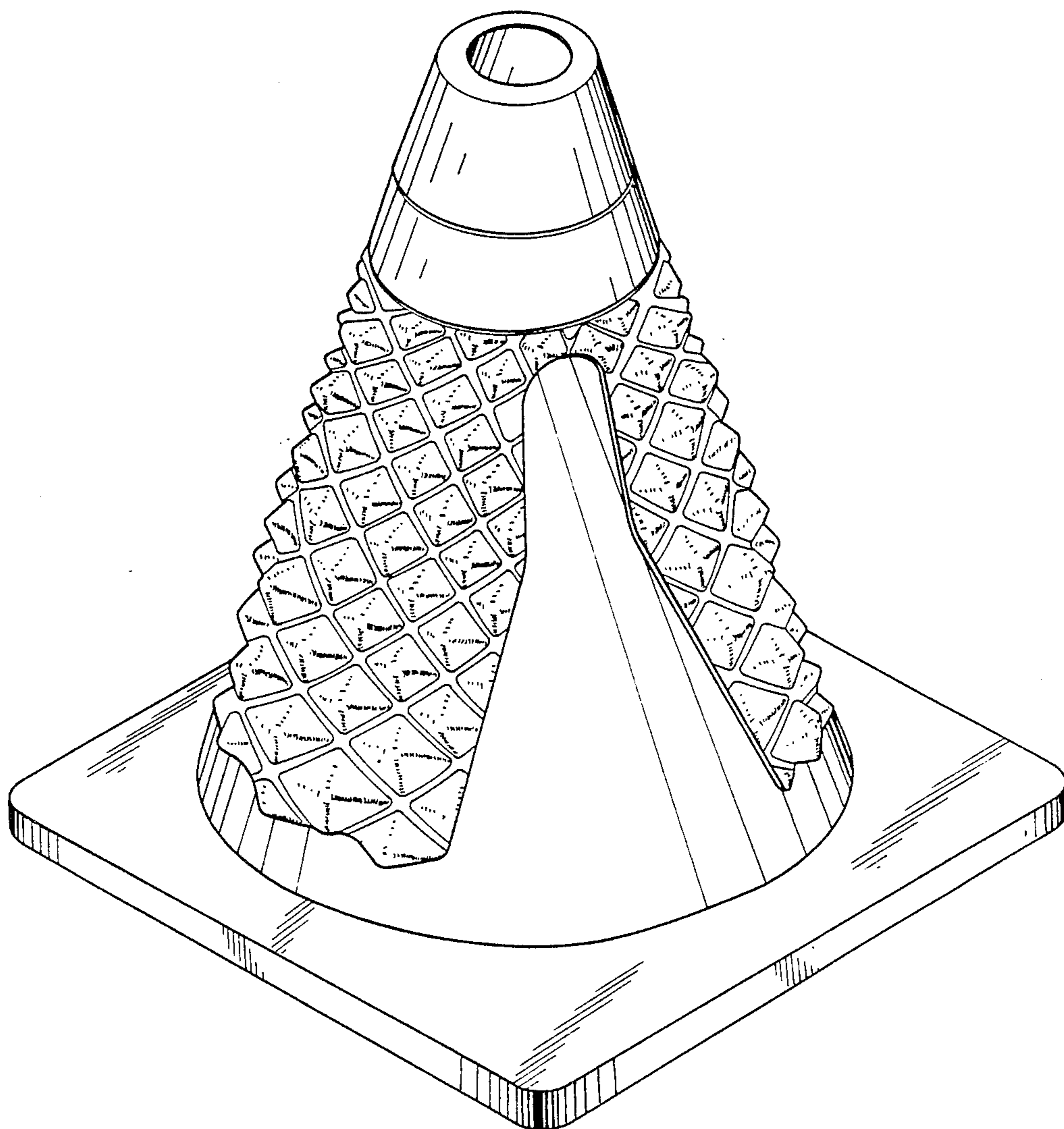

FIG. 1

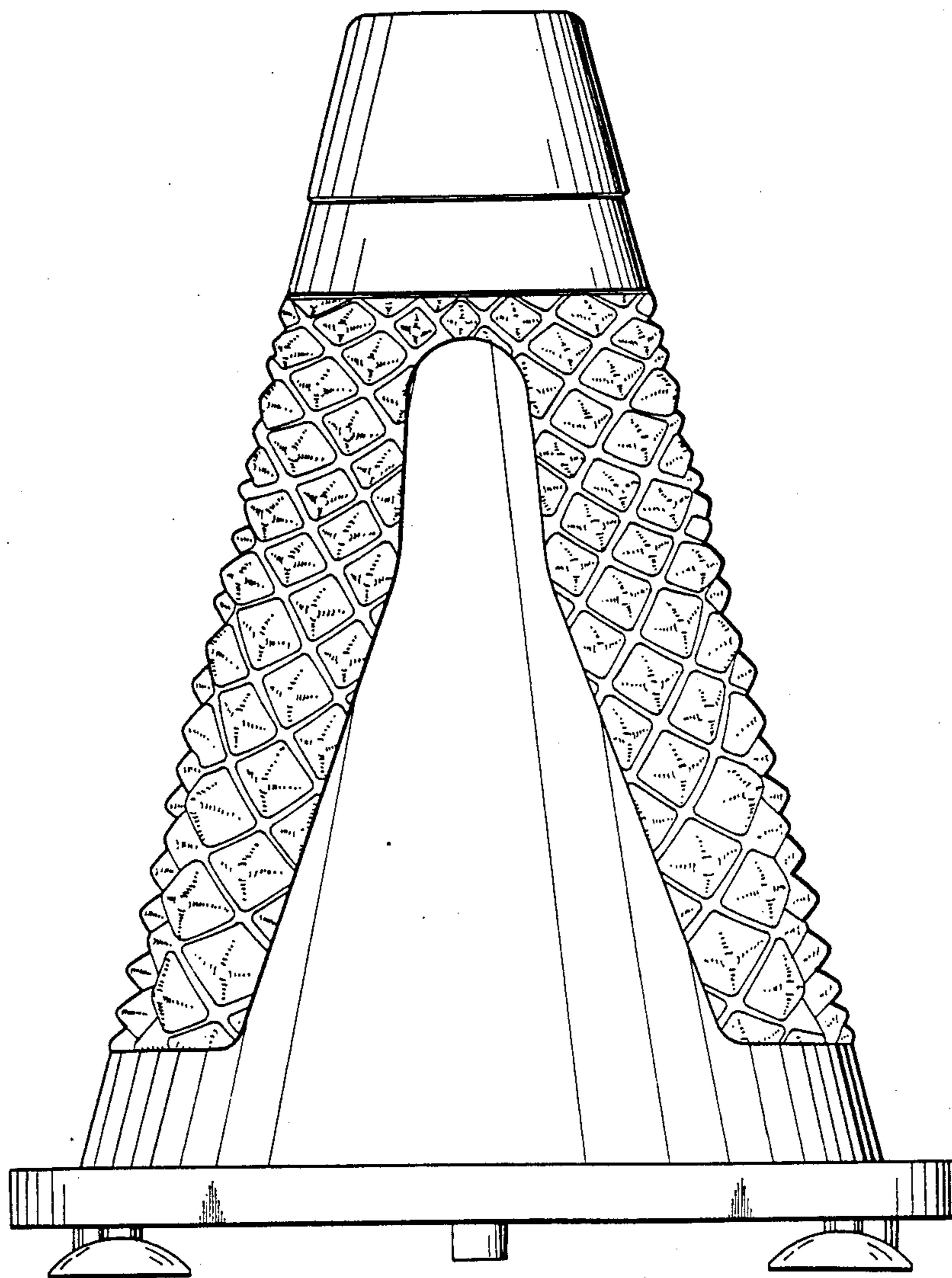

FIG 2

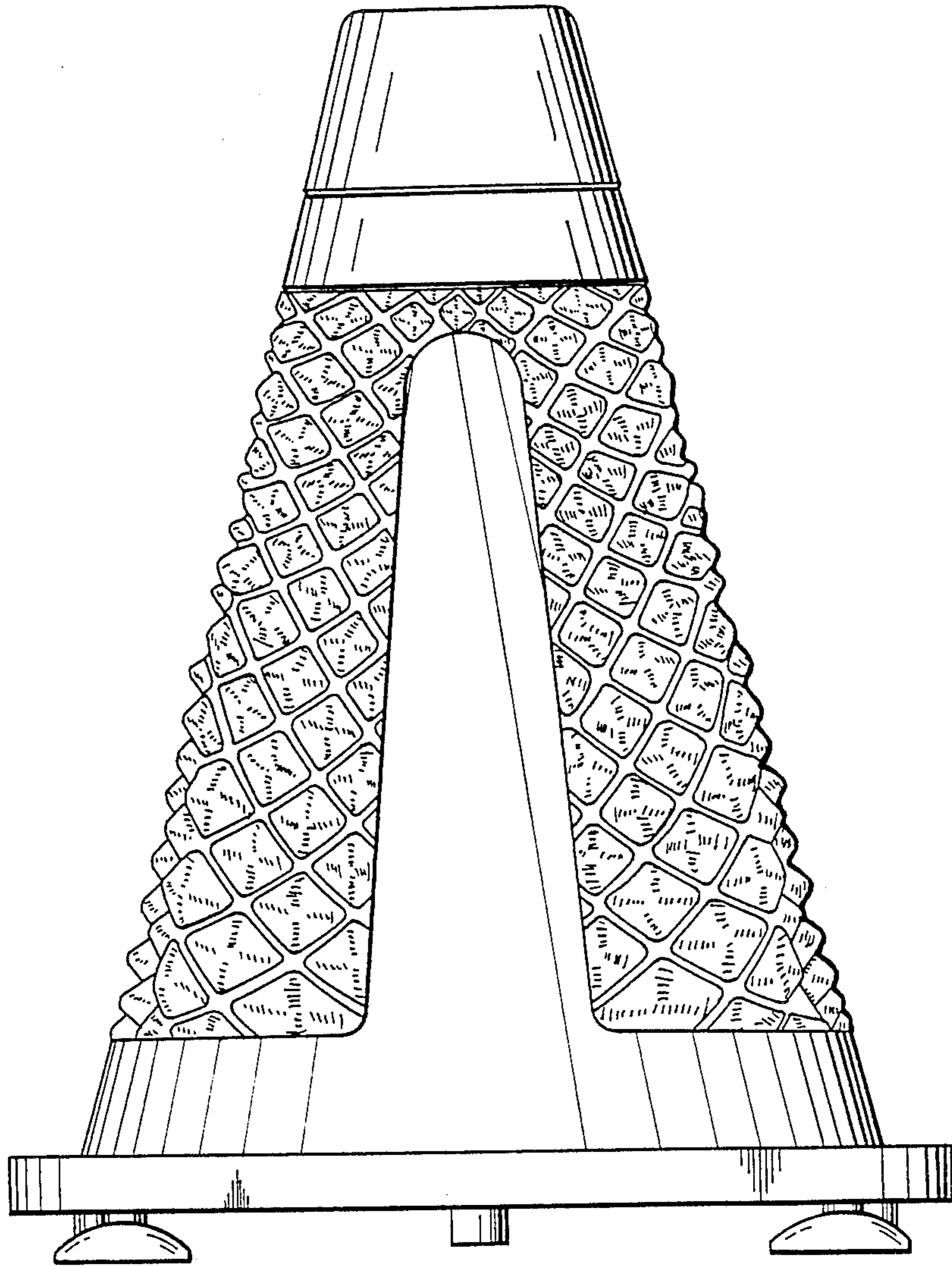

FIG. 3

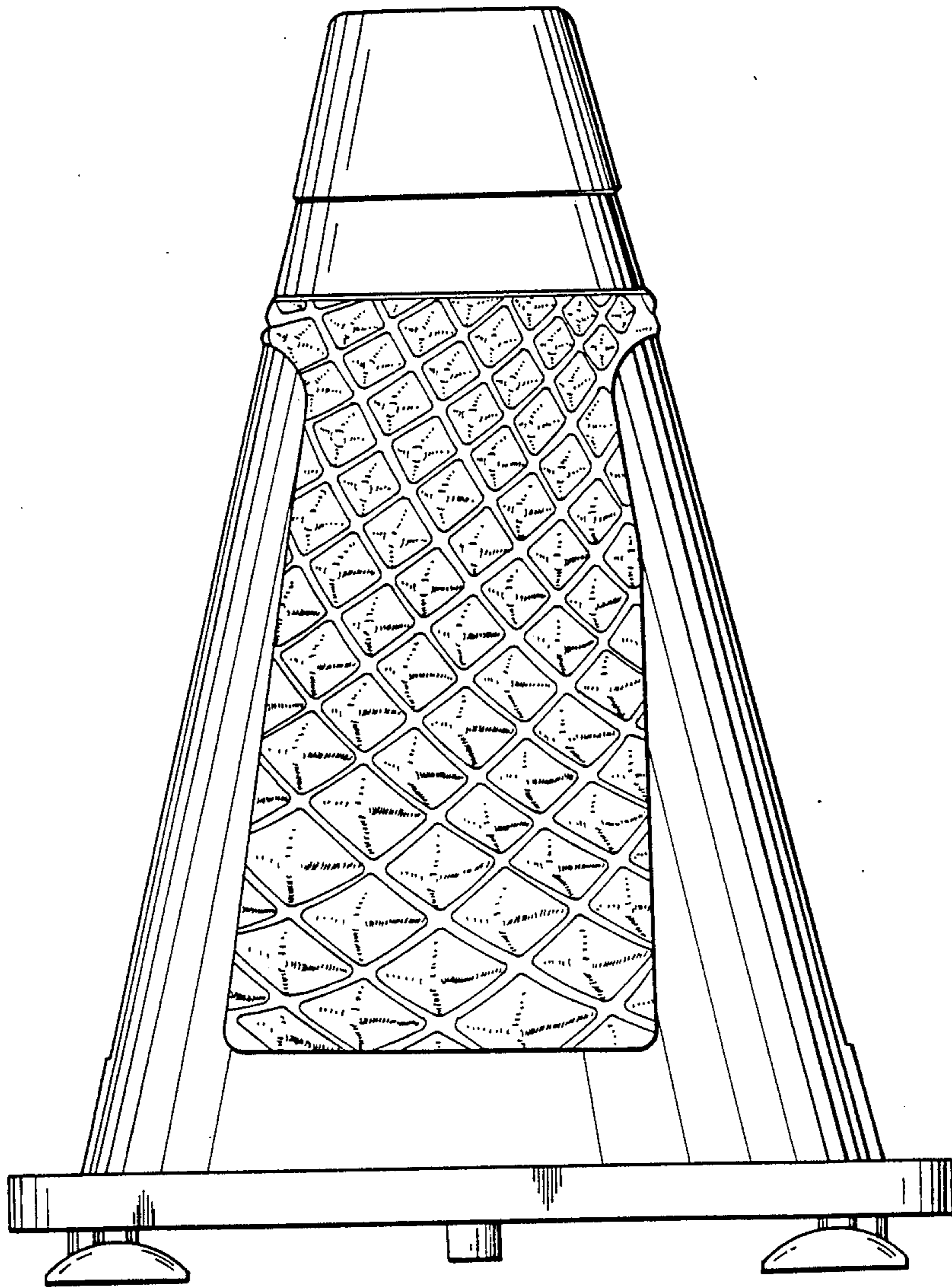

FIG. 4

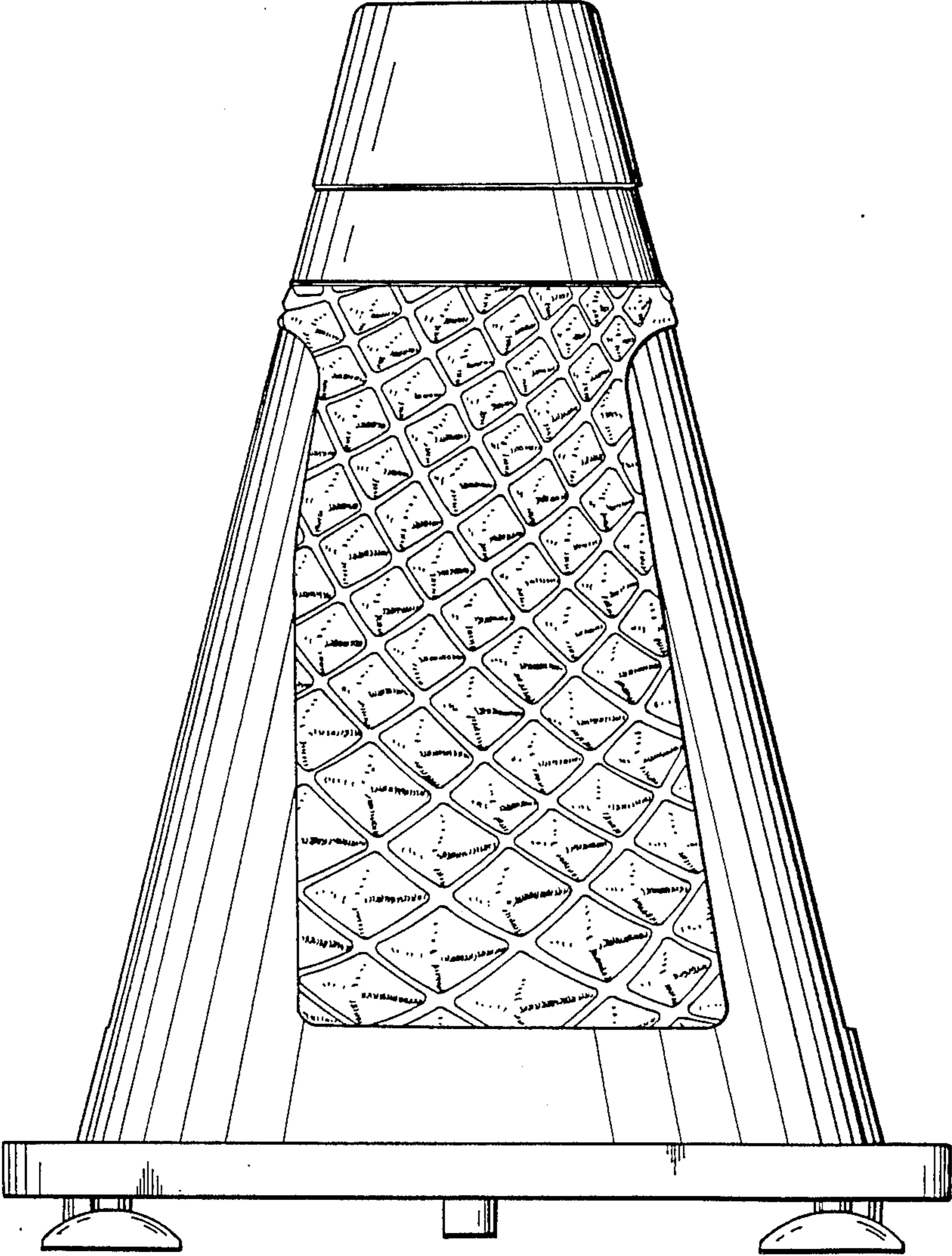

FIG 5

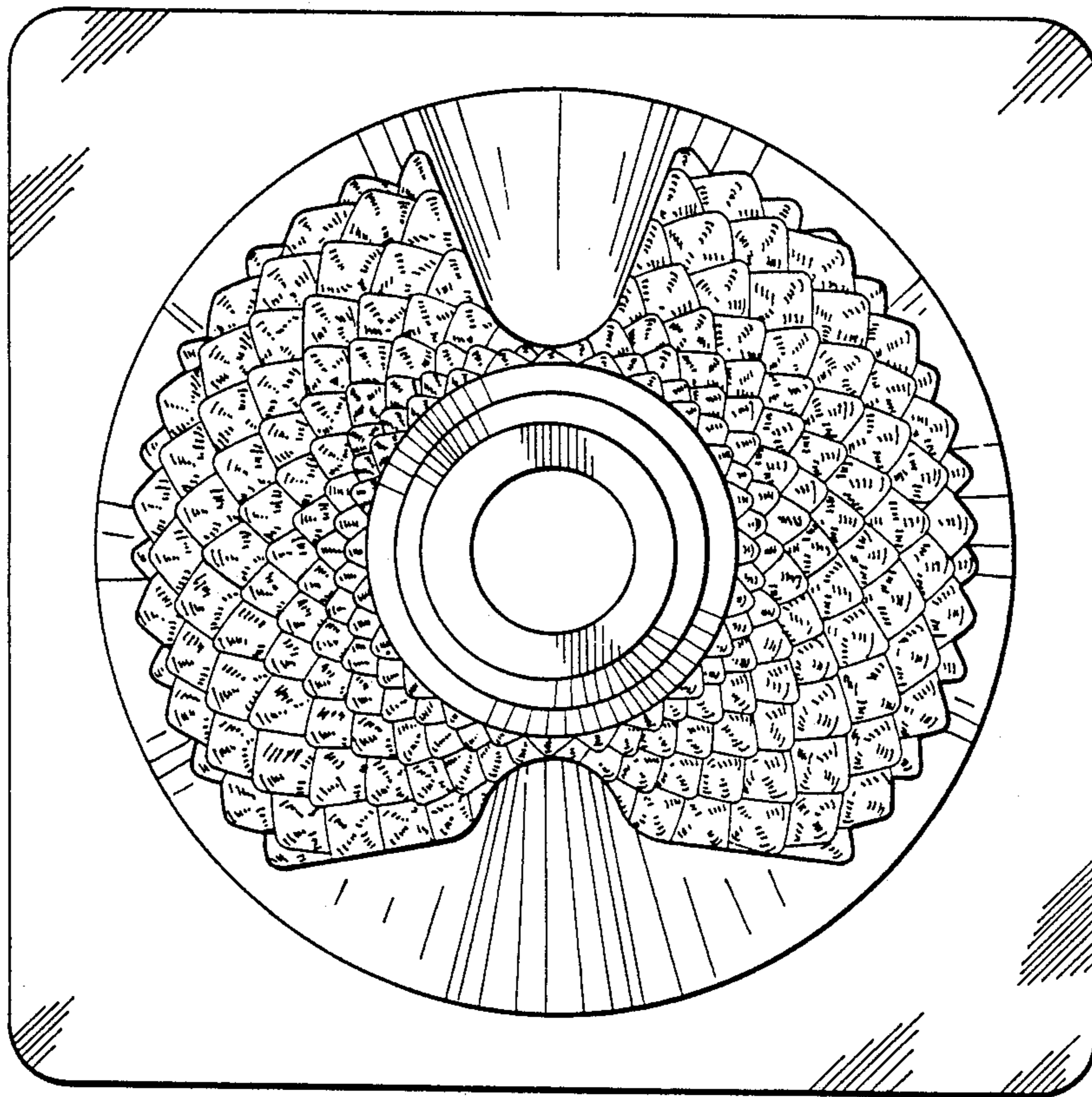

FIG. 6

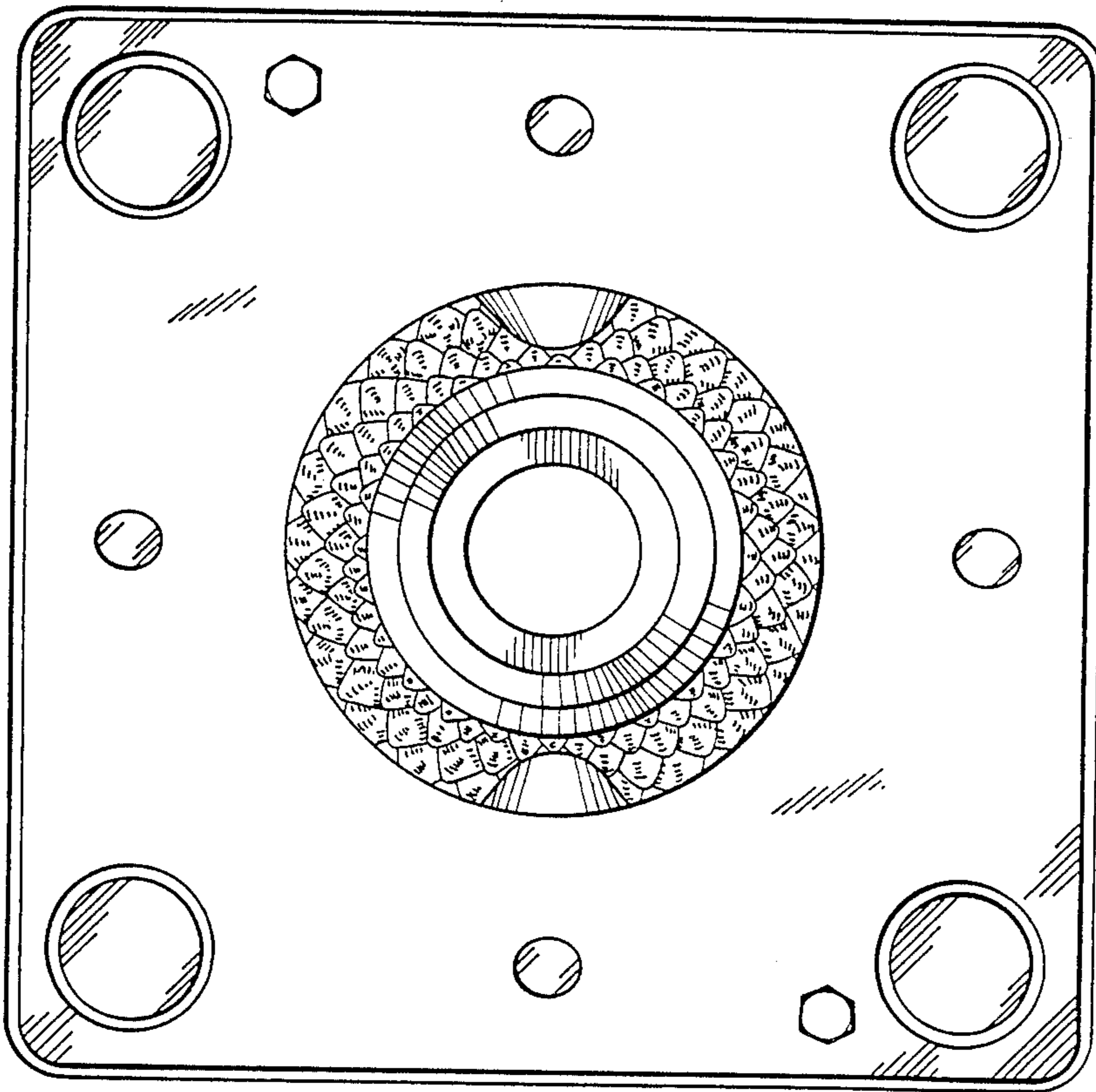

FIG. 7