

[54] **RAIN CAP FOR AN ENGINE EXHAUST
STACK OR PIPE**

4,205,706 6/1980 Jasensky 138/89
4,495,859 1/1985 Janke 98/59

[76] **Inventor: Robert Brill, 805 Noble Ct., Golden,
Colo. 80401**

FOREIGN PATENT DOCUMENTS

3020 of 1896 United Kingdom 98/73

[**] **Term: 14 Years**

Primary Examiner—James M. Gandy
Attorney, Agent, or Firm—Gregg I. Anderson

[21] **Appl. No.: 815,259**

[57] **CLAIM**

[22] **Filed: Dec. 31, 1985**

[52] **U.S. Cl. D12/194**

The ornamental design for a rain cap for an engine exhaust stack or pipe, as shown.

[58] **Field of Search D12/194; 98/59, 122,
98/73; 138/89**

DESCRIPTION

[56] **References Cited**

U.S. PATENT DOCUMENTS

2,396,876 3/1946 Olsen 98/73
3,446,010 5/1969 Hopkins 60/29
3,964,376 6/1976 Janke 98/59
4,059,045 11/1977 McClain 98/122

FIG. 1 is a perspective view of a rain cap for an engine exhaust stack or pipe of the present design.

FIG. 2 is a front elevational view thereof.

FIG. 3 is a rear elevational view thereof.

FIG. 4 is a side elevational view thereof.

FIG. 5 is a top plan view thereof.

FIG. 6 is a bottom plan view thereof.

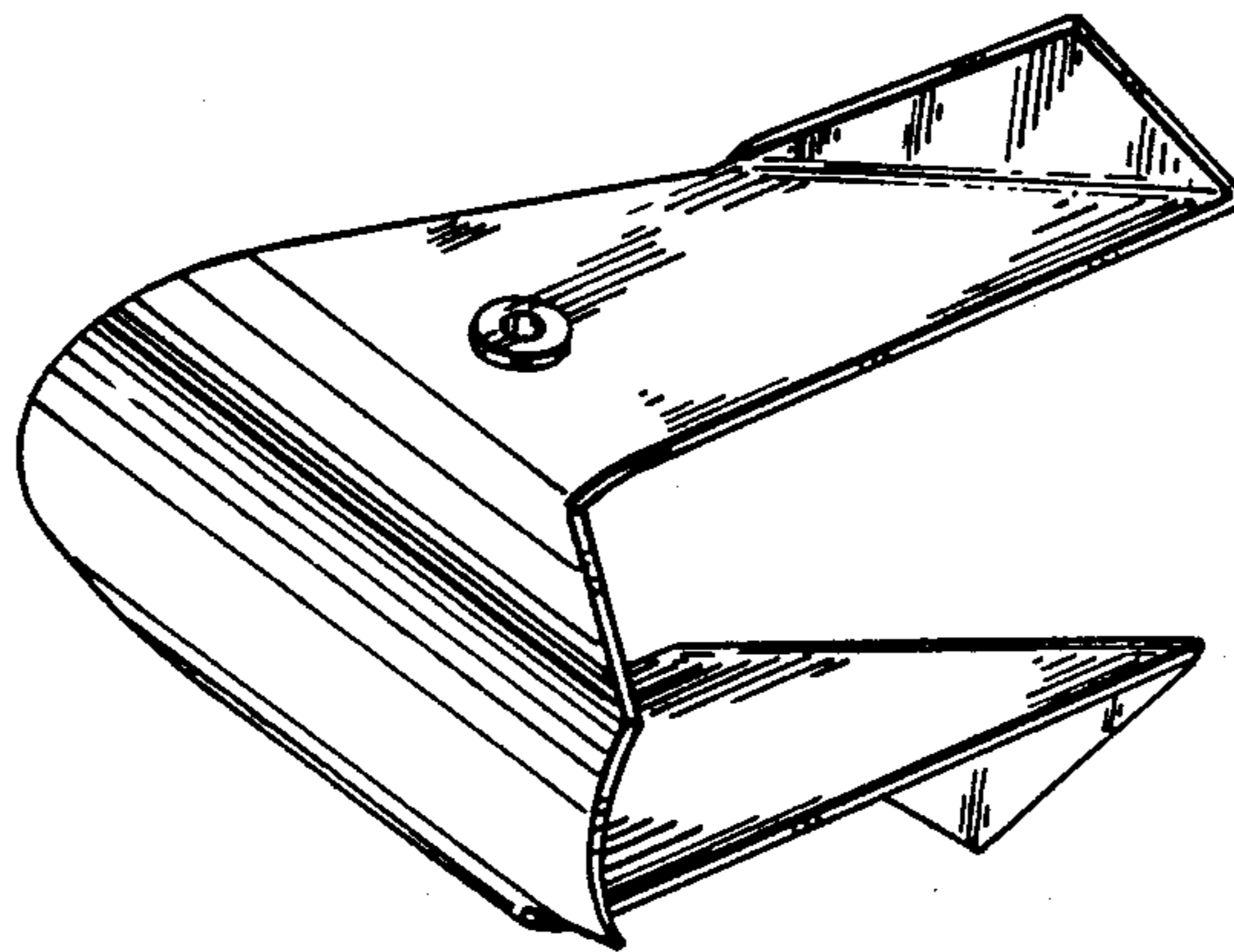

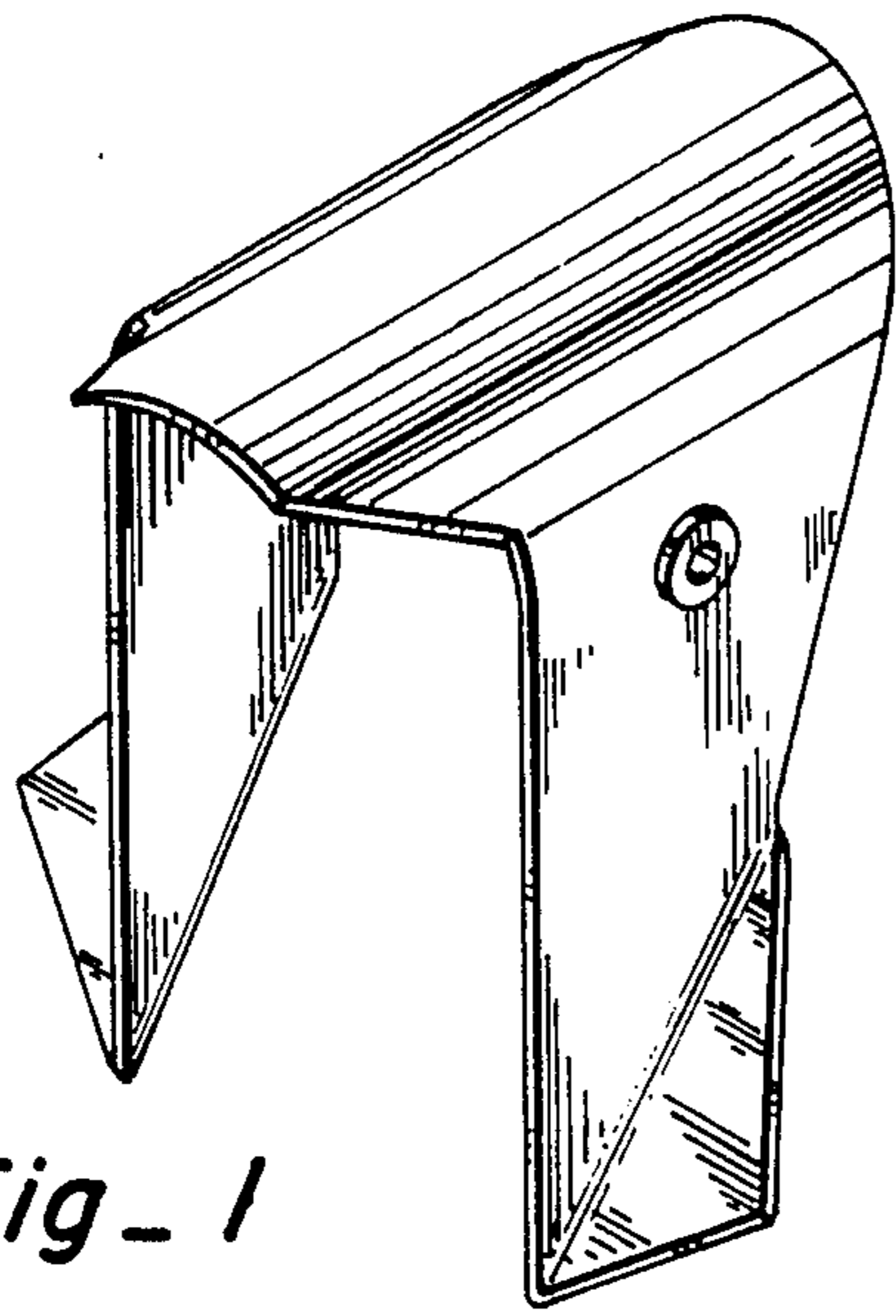

Fig-1

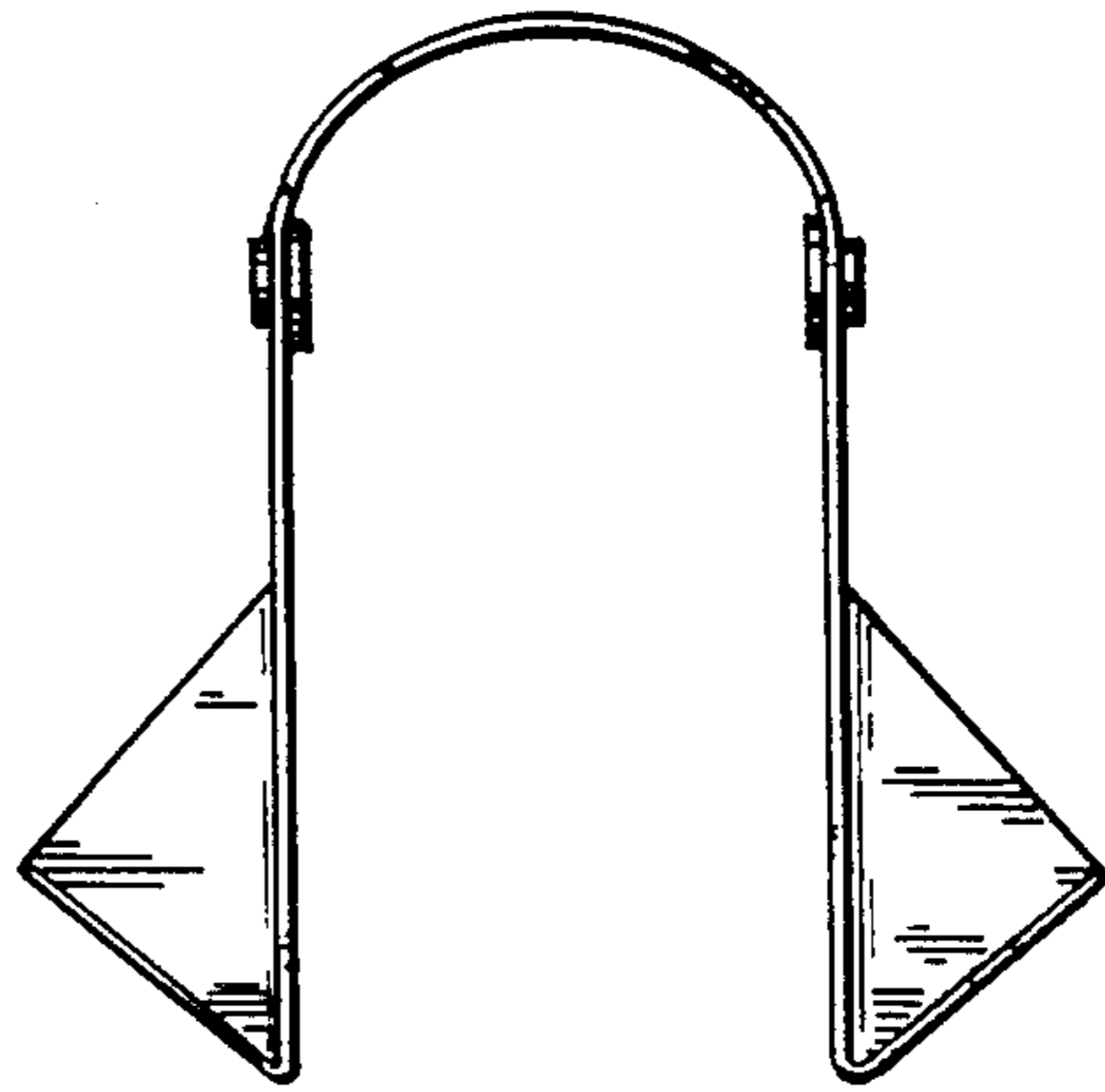

Fig-2

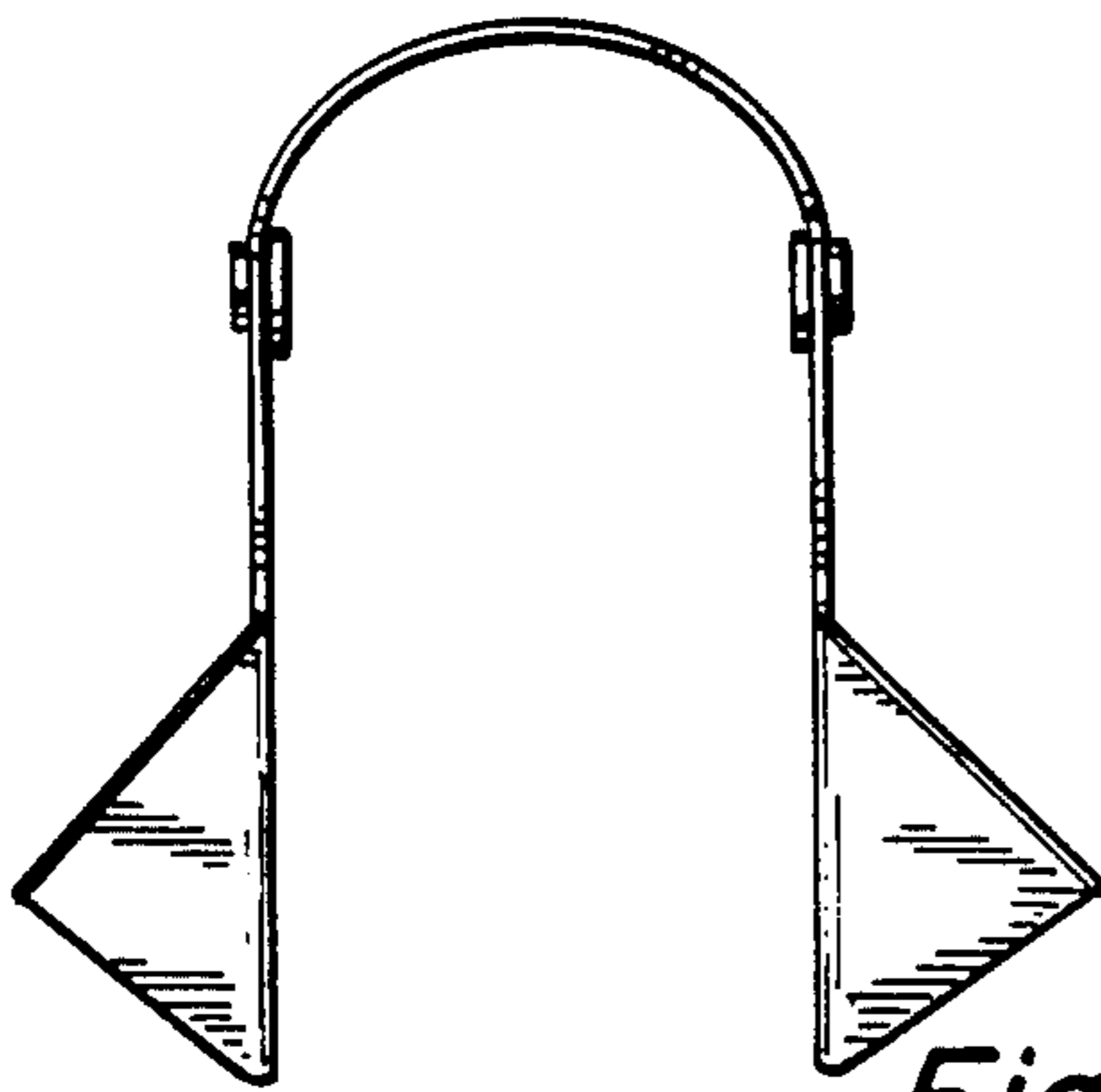

Fig-3

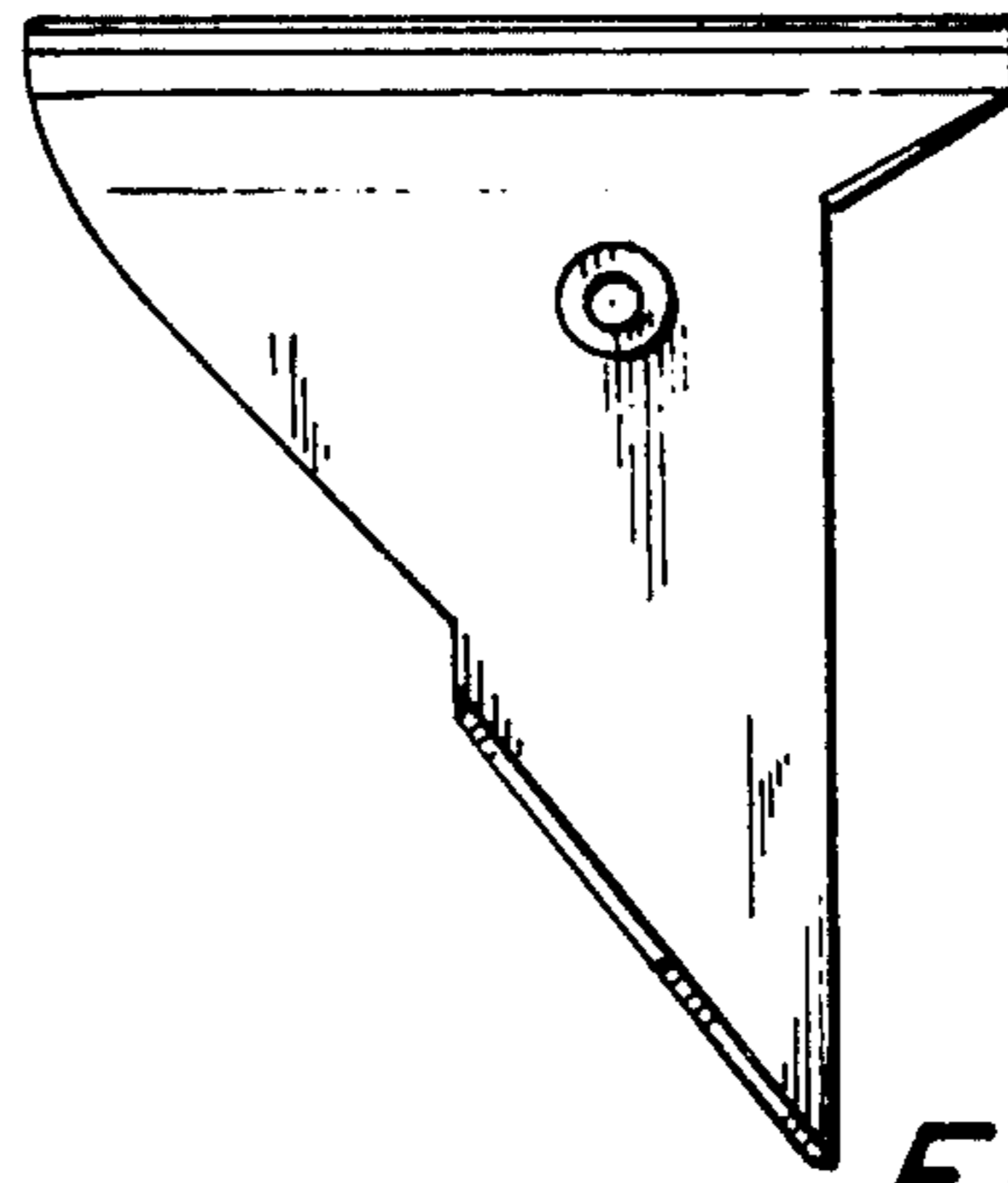

Fig-4

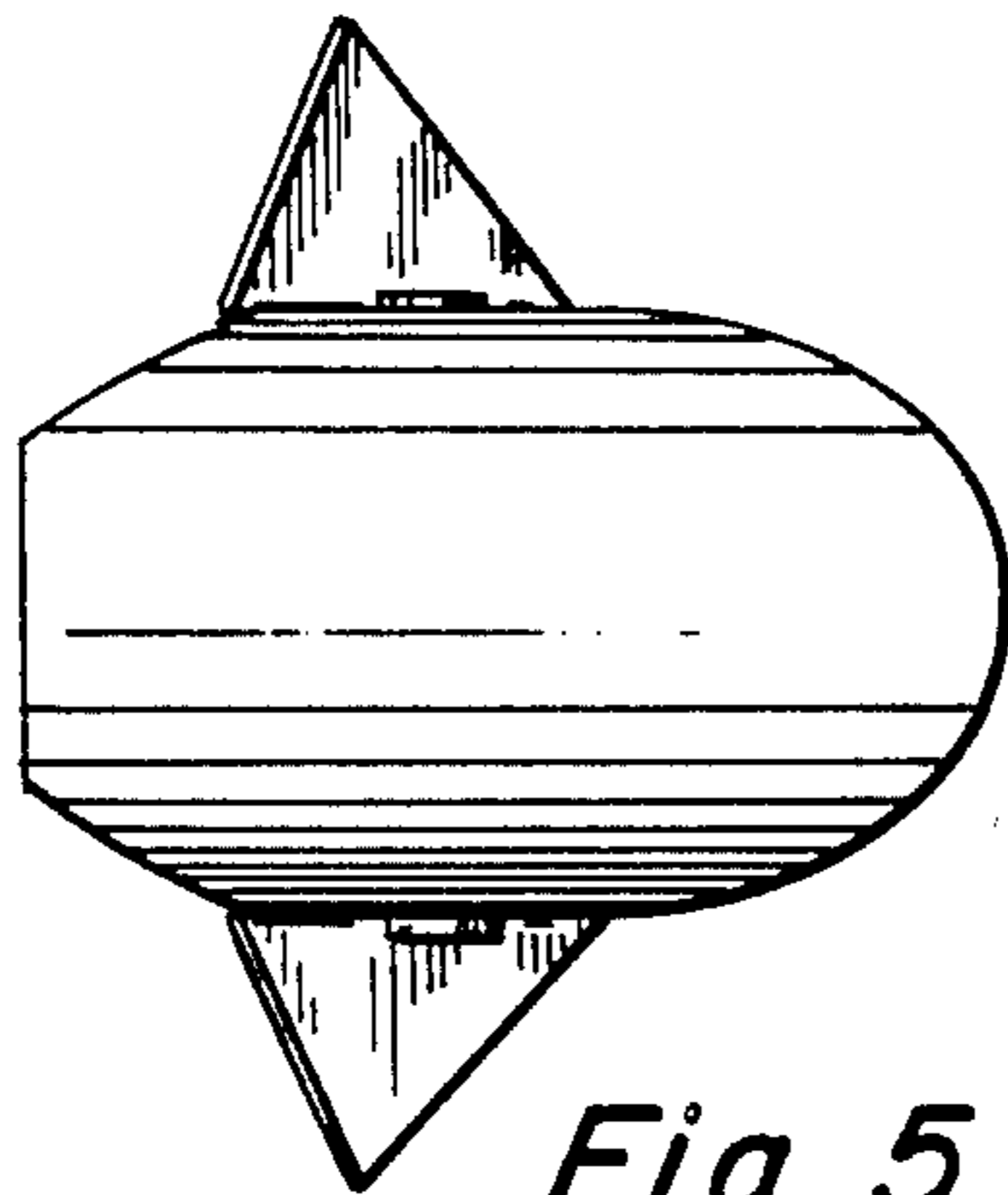

Fig-5

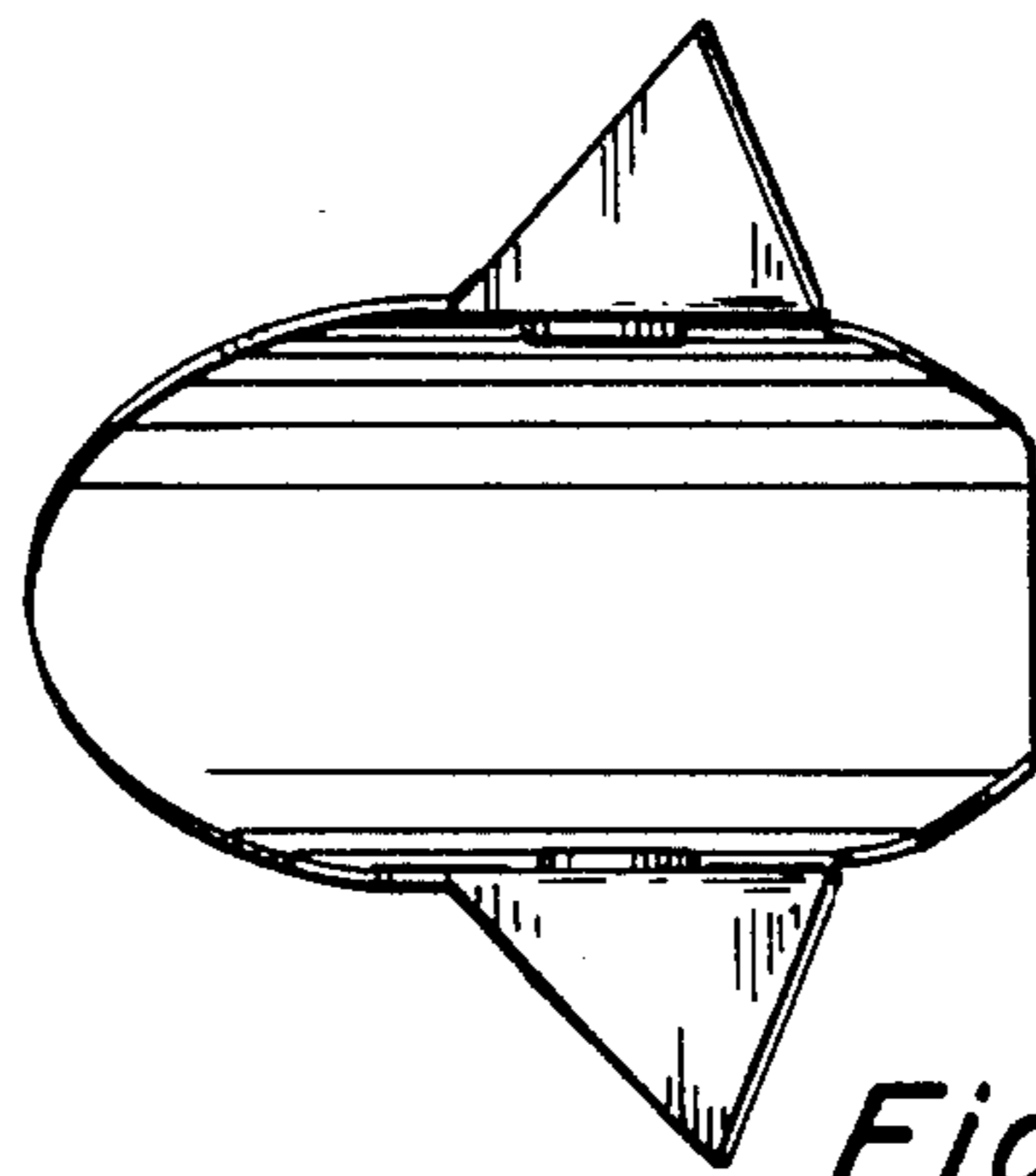

Fig-6