

[54] FRONT FENDER FOR AN AUTOMOBILE

[75] Inventors: Masahiko Kawatsu; Tokuo Fukuichi, both of Toyota, Japan

[73] Assignee: Toyota Jidosha Kabushiki Kaisha, Toyota, Japan

[**] Term: 14 Years

[21] Appl. No.: 760,915

[22] Filed: Jul. 31, 1985

[52] U.S. Cl. D12/184

[58] Field of Search D12/184

[56] References Cited

U.S. PATENT DOCUMENTS

- D. 240,914 8/1976 Wilgaard D12/184
- D. 246,708 12/1977 Tixler D12/184
- D. 276,332 11/1984 Wilgaard D12/184

OTHER PUBLICATIONS

Motor Trend, 6/84, p. 139, front fender of Ford LTD, center left side of page.

Motor Trend, 2/84, p. 18, front fender of Mitsubishi automobile, center of page.

Primary Examiner—James M. Gandy
Attorney, Agent, or Firm—Cushman, Darby & Cushman

[57] CLAIM

The ornamental design for a front fender for an automobile, as shown.

DESCRIPTION

FIG. 1 is a perspective view of a front fender for an automobile showing our new design;
 FIG. 2 is a front elevational view thereof;
 FIG. 3 is a rear elevational view thereof;
 FIG. 4 is a top plan view thereof;
 FIG. 5 is a bottom plan view thereof;
 FIG. 6 is a left side elevational view thereof;
 FIG. 7 is a right side elevational view thereof;
 FIG. 8 is a cross-sectional view thereof on line 8—8 of FIG. 2; and
 FIG. 9 is a cross-sectional view thereof on line 9—9 of FIG. 2.

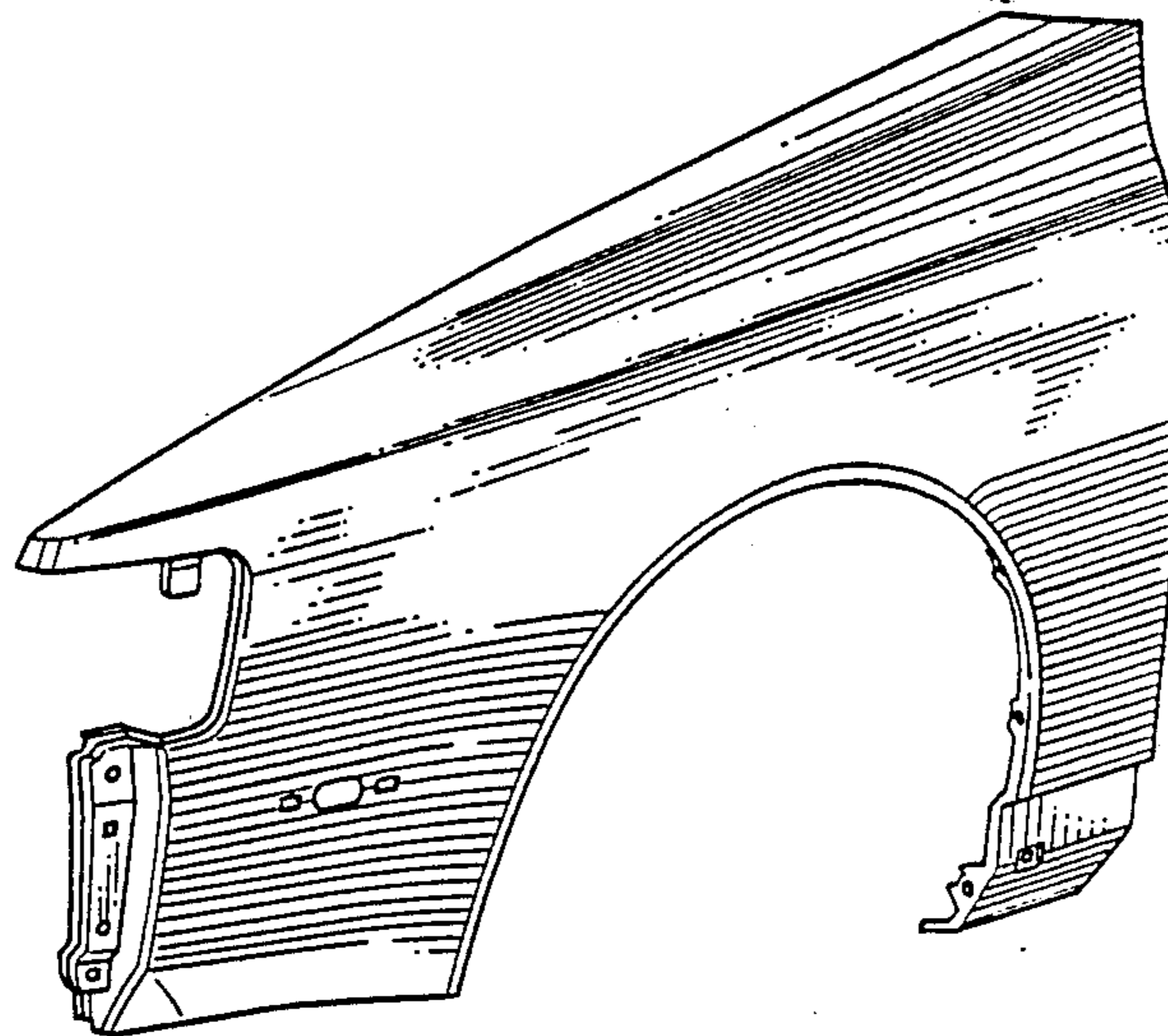

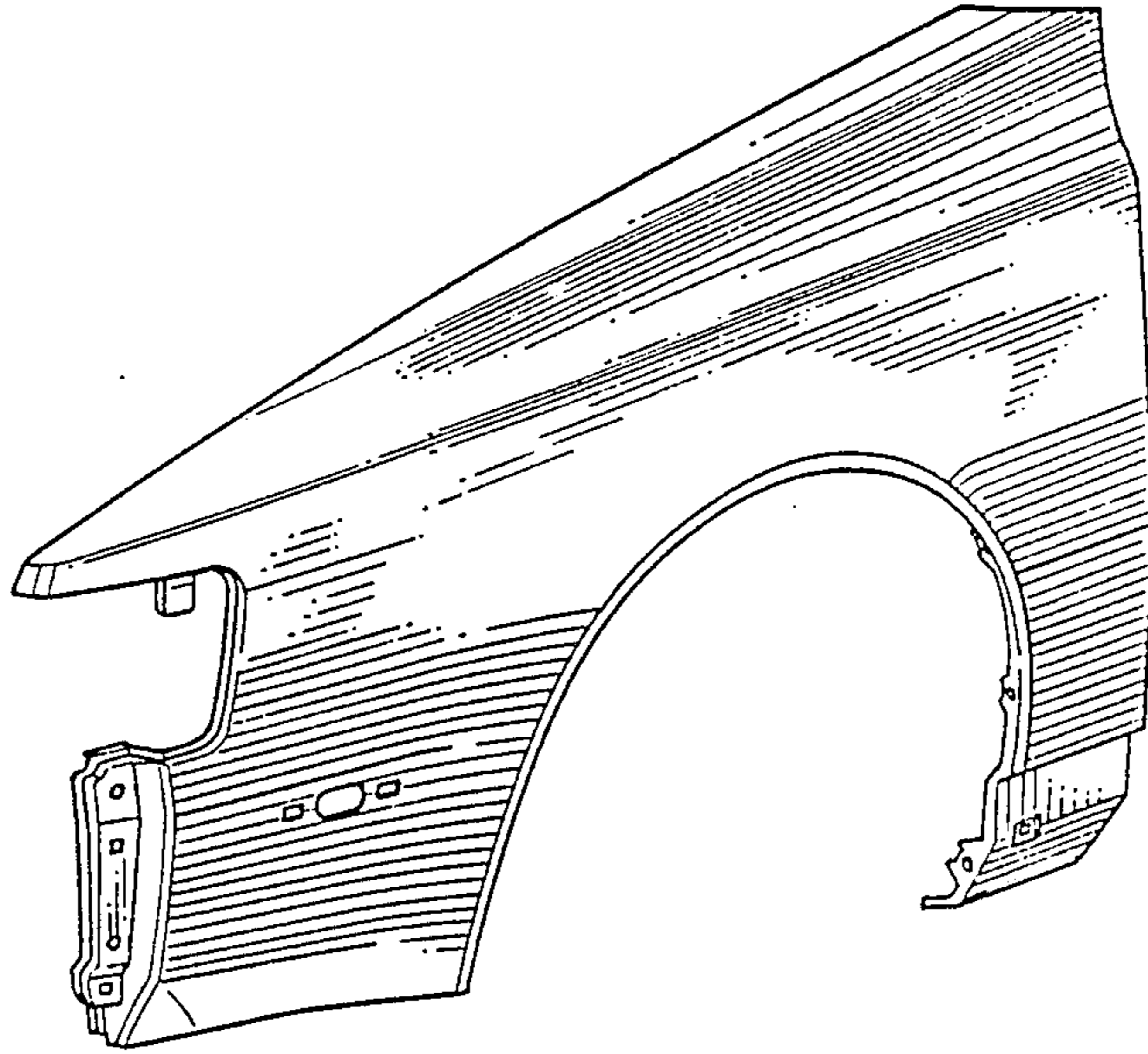

Fig. 1

Fig. 3

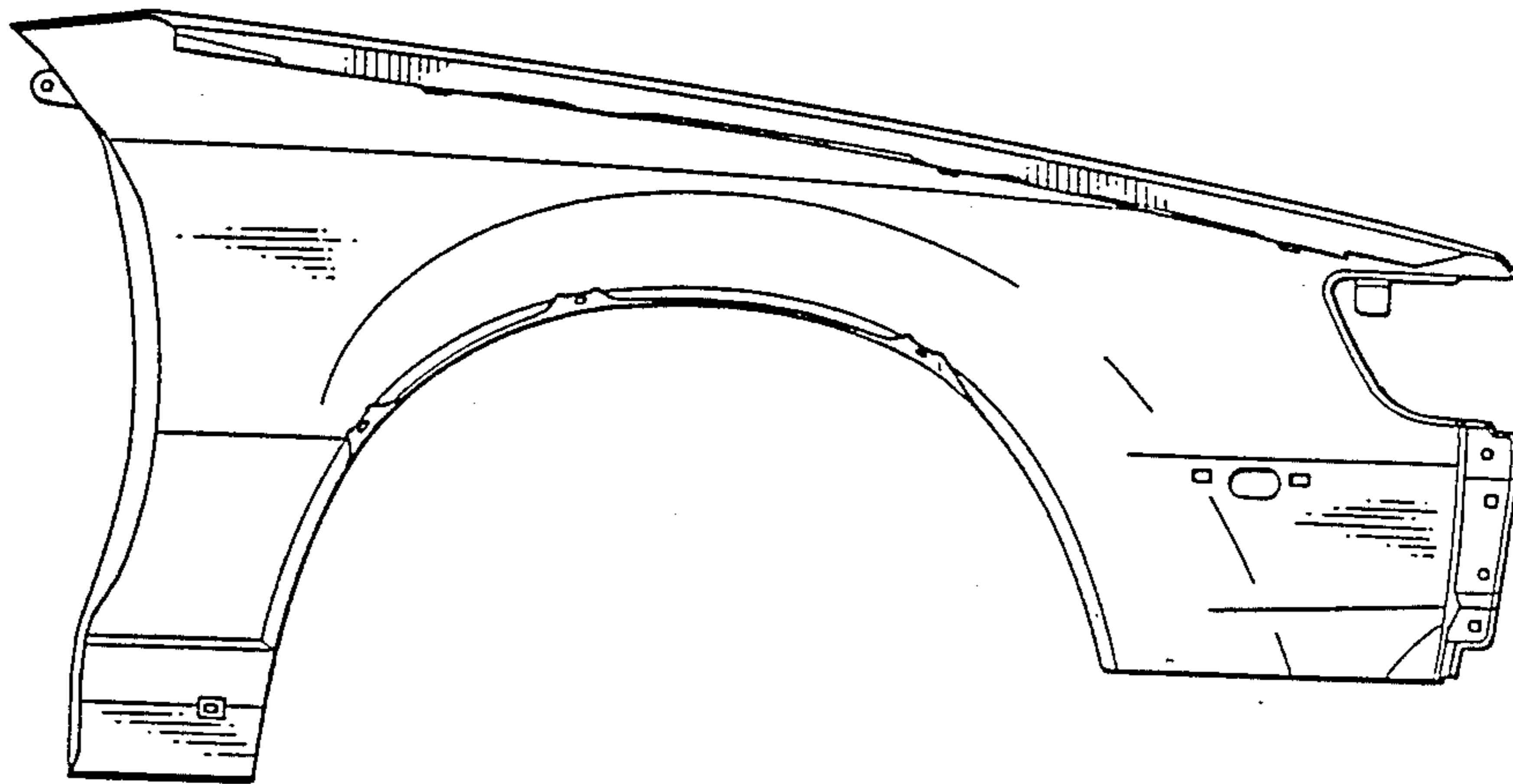

Fig. 2

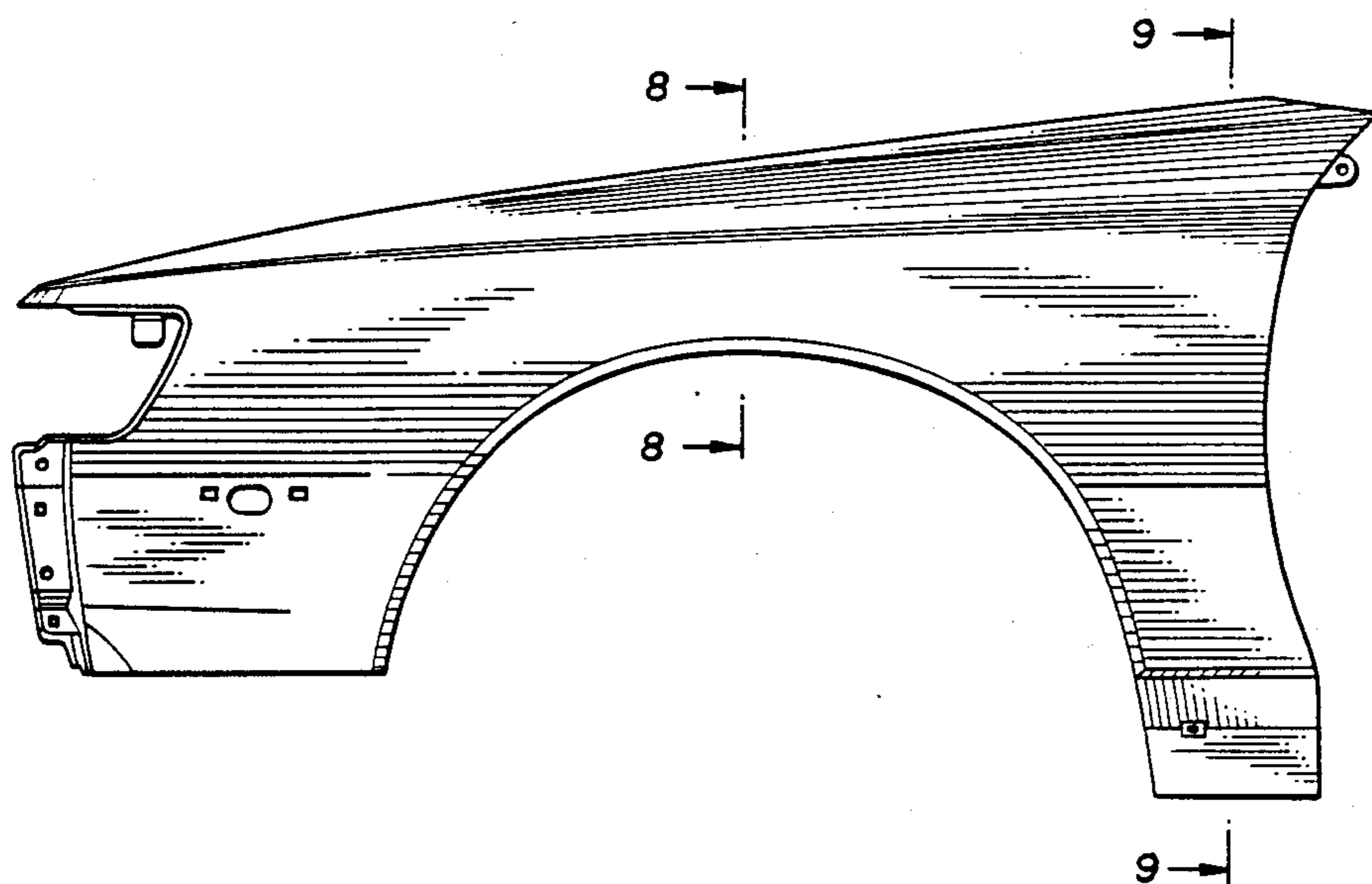

Fig. 8

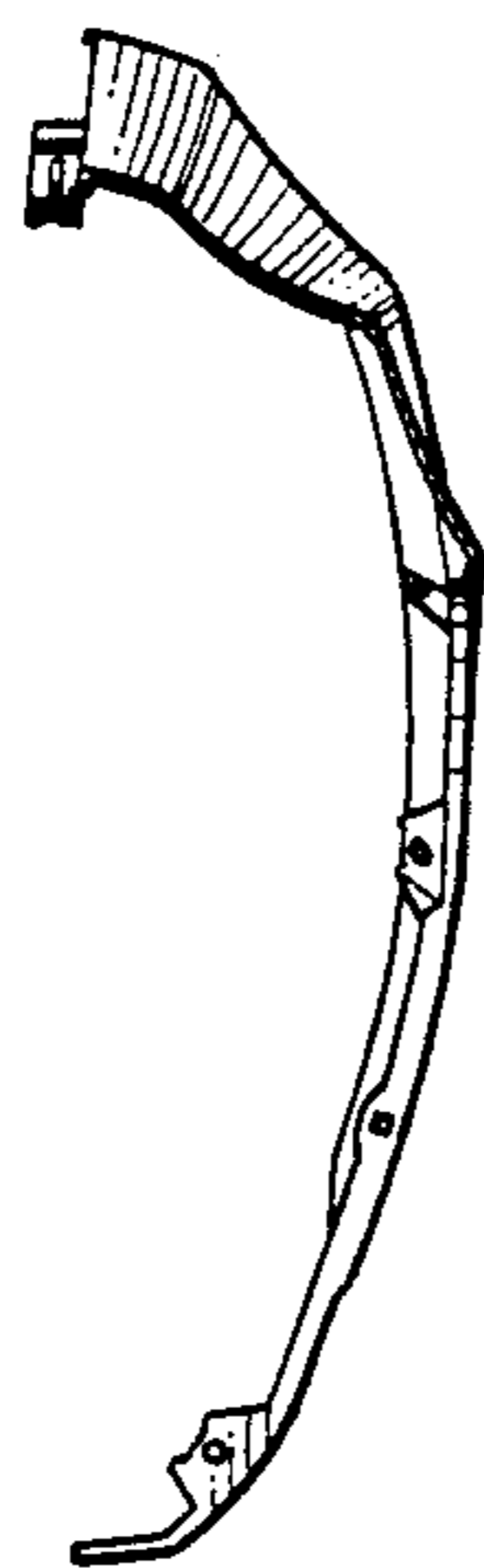

Fig. 9



Fig. 4

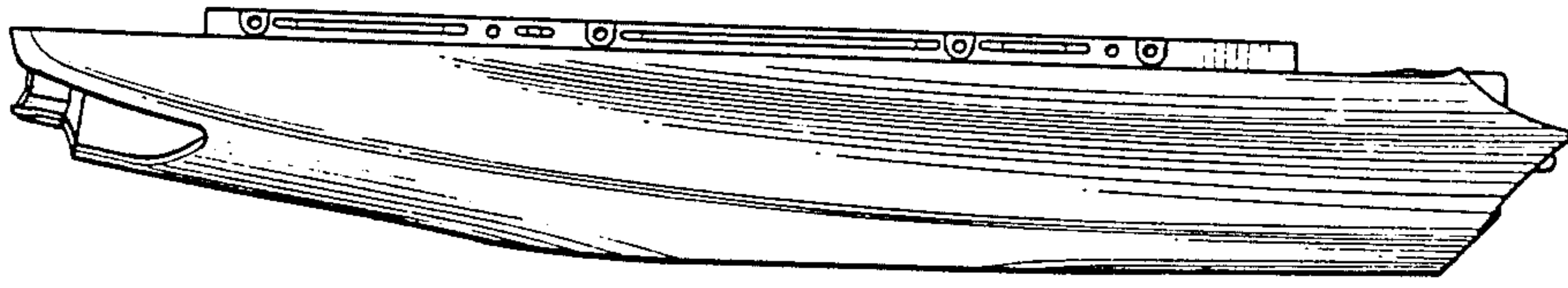

Fig. 5

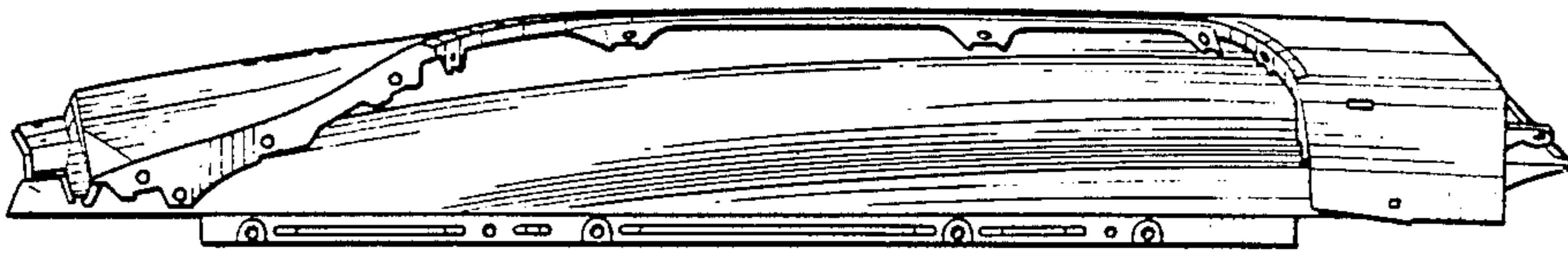

Fig. 6

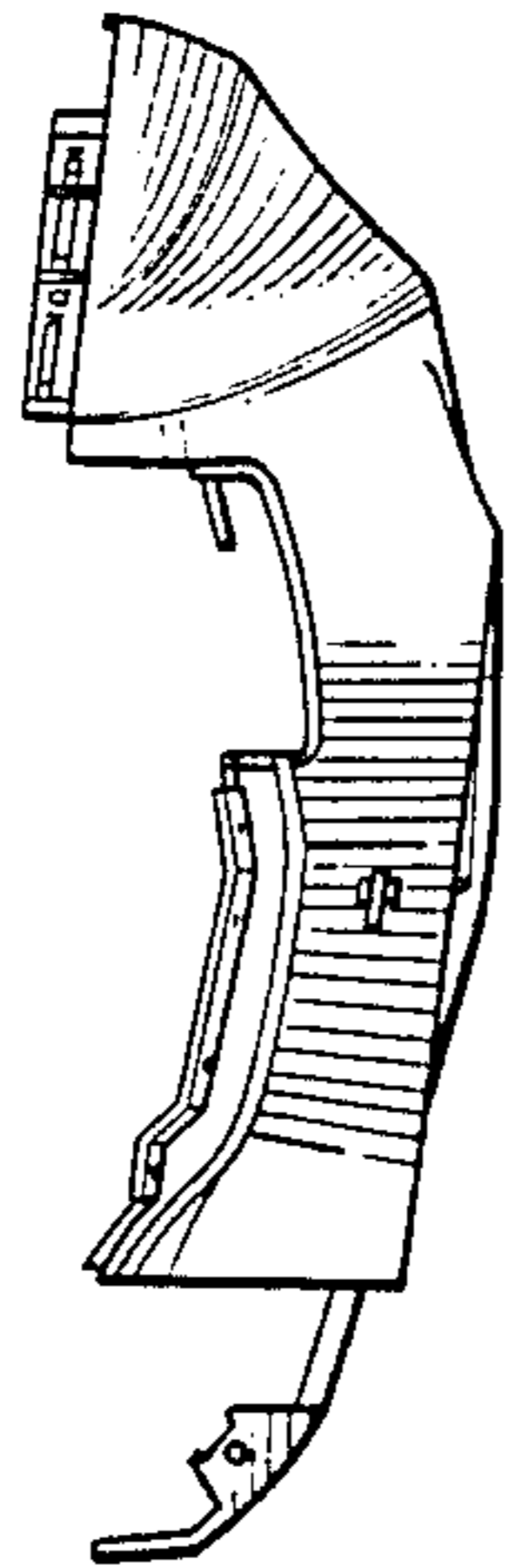

Fig. 7

