

[54] FRONT MUDGUARD FOR AN AUTOMOTIVE VEHICLE

[75] Inventor: Ermanno Cressoni, Arese, Italy

[73] Assignee: Alfa Romeo Auto S.p.A., Naples, Italy

[**] Term: 14 Years

[21] Appl. No.: 728,935

[22] Filed: Apr. 30, 1985

[30] Foreign Application Priority Data

Oct. 31, 1984 [IT] Italy 23665/84[U]

[52] U.S. Cl. D12/184

[58] Field of Search D12/184; 280/152 R, 280/153 R

[56] References Cited PUBLICATIONS

Autocar, 2/11/84, p. 25, Front Fender of Alfa Romeo Alfa 33, top of page.

Road & Track, 4/84, p. 5, Sear Ronda Front Fender, top left side of page and p. 37, Alfa Romeo Type 164 Front Fender, bottom center of page.

Motor Trend, 3/84, p. 16, Fiat Tipo 3 Front Fender, top center of page.

Road & Track, 2/84, p. 85, G. M. Saturn Front Fender, top center of page.

Primary Examiner—James M. Gandy
Attorney, Agent, or Firm—Charles E. Brown; Charles A. Brown

[57] CLAIM

The ornamental design for a front mudguard for an automotive vehicle, as shown and described.

DESCRIPTION

FIG. 1 is a front elevation view of a front mudguard for an automotive vehicle showing my new design, it being understood that the broken lines are for illustrative purposes only and form no part of the claimed design; FIG. 2 is a rear elevation view thereof; FIG. 3 is a front elevation view thereof; FIG. 4 is a top plan view thereof; FIG. 5 is a bottom plan view thereof; FIG. 6 is an end elevation view thereof looking in the direction of arrow 6 in FIG. 2; and FIG. 7 is an end elevation view thereof looking in the direction of arrow 7 in FIG. 3.

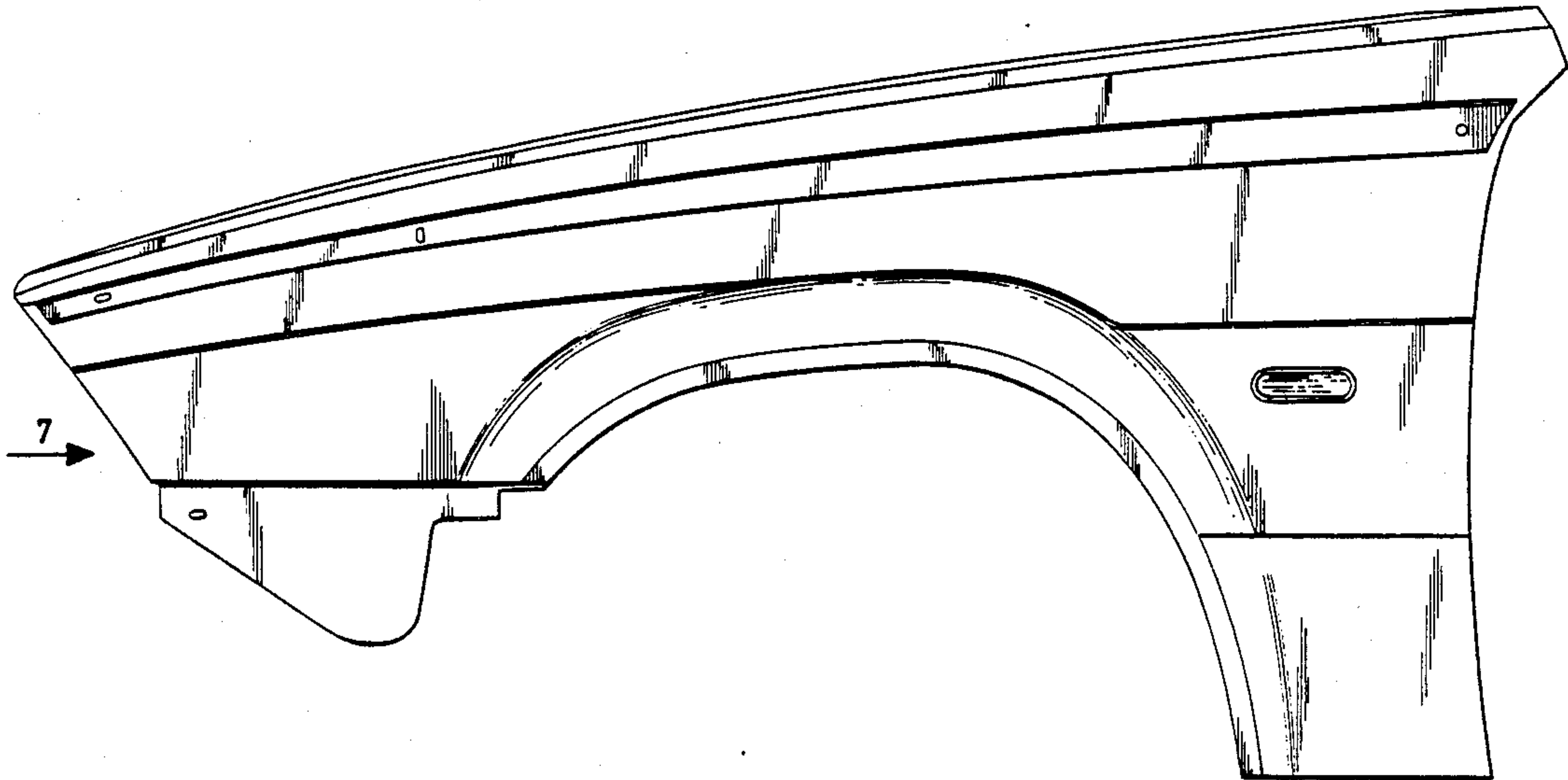

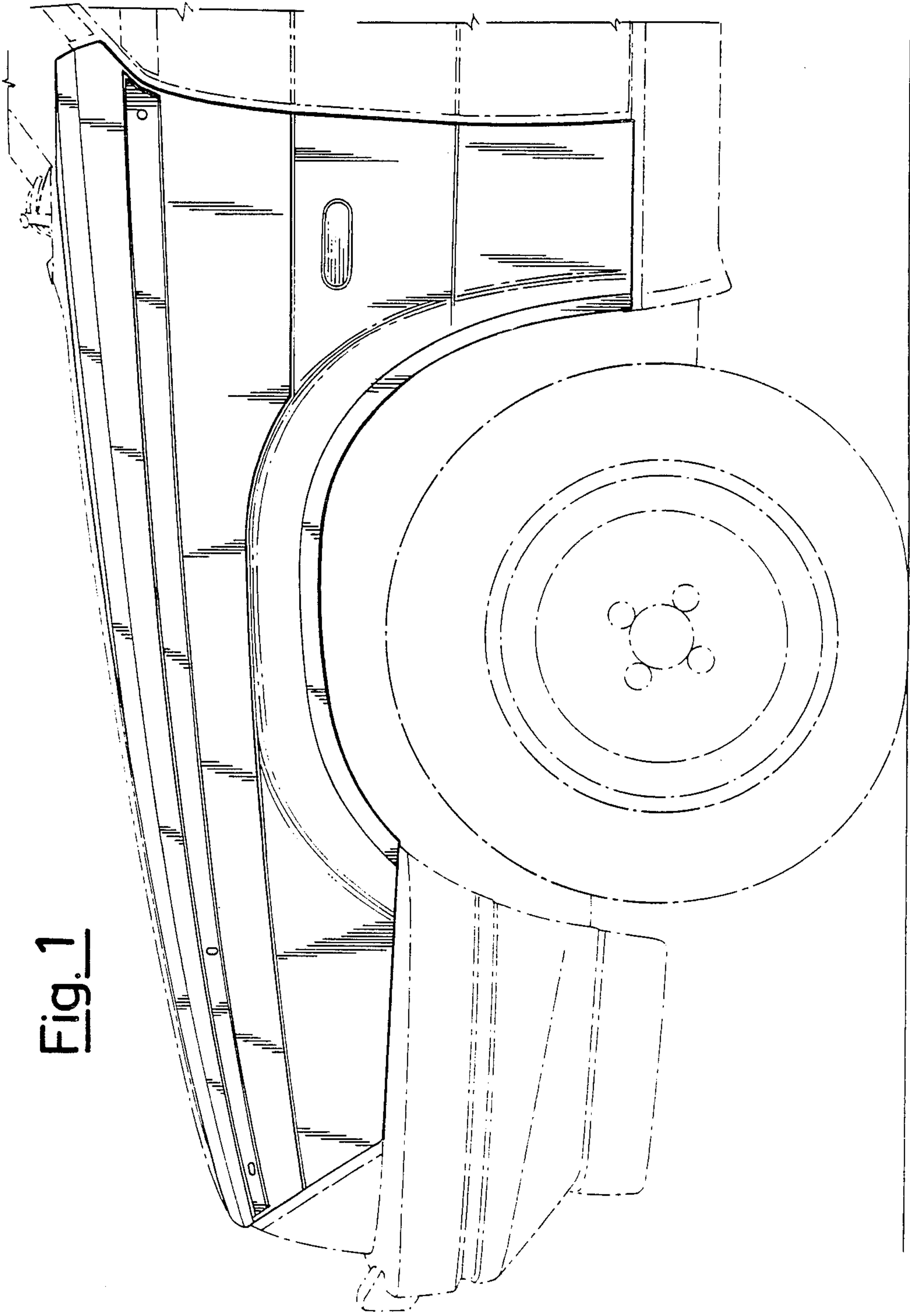

Fig. 1

Fig. 2

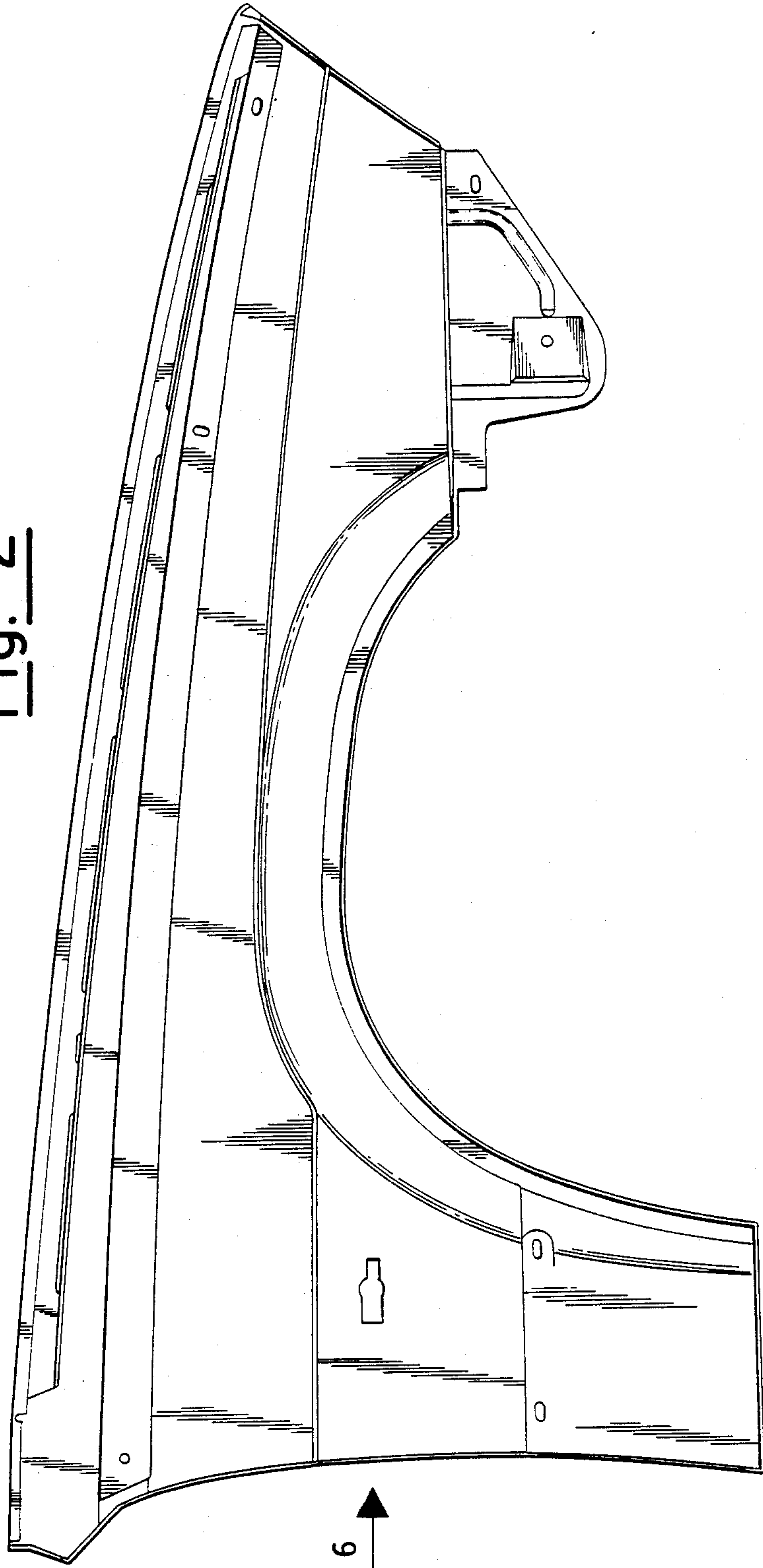

Fig. 3

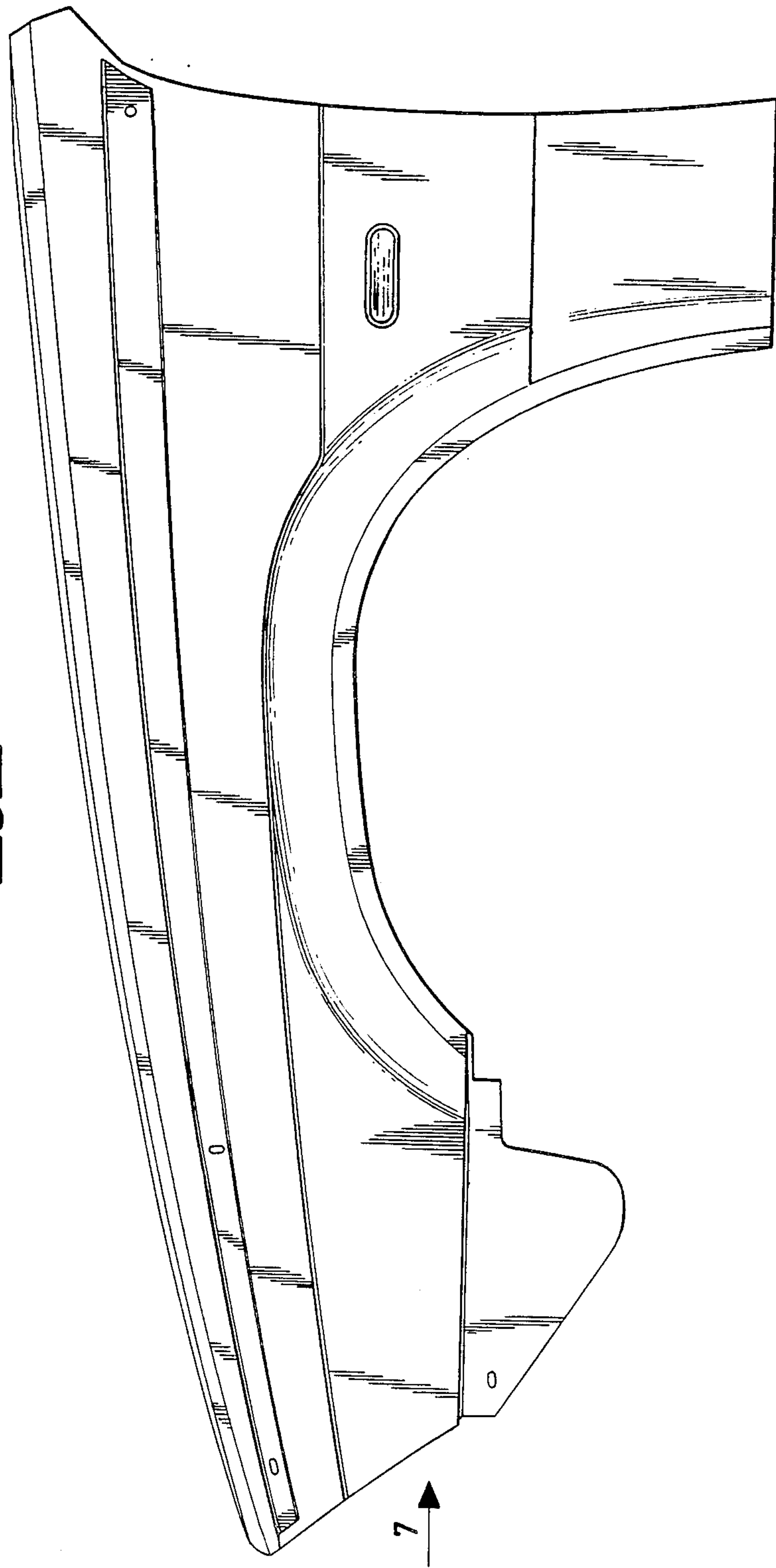

Fig. 4

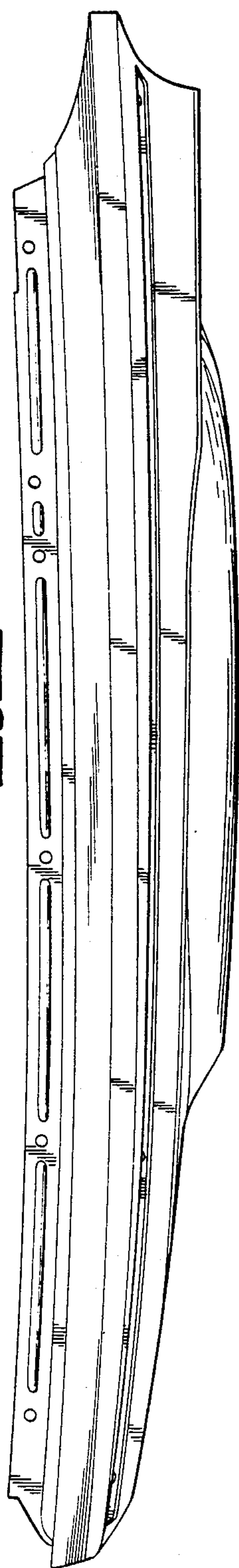

Fig. 5

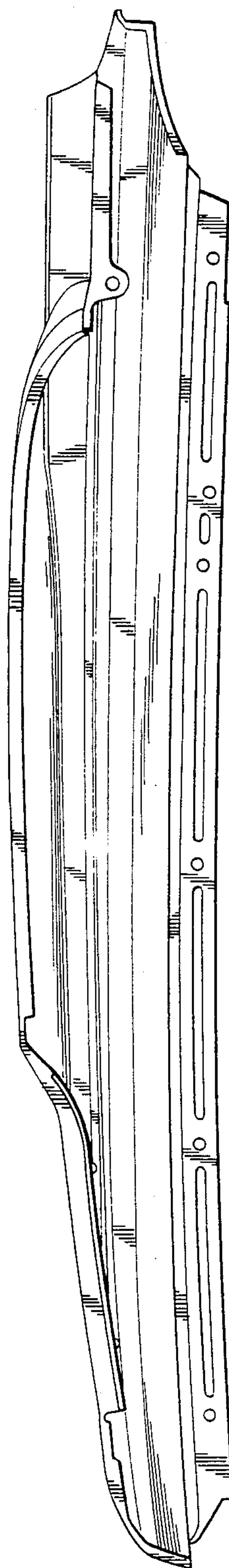

Fig. 6

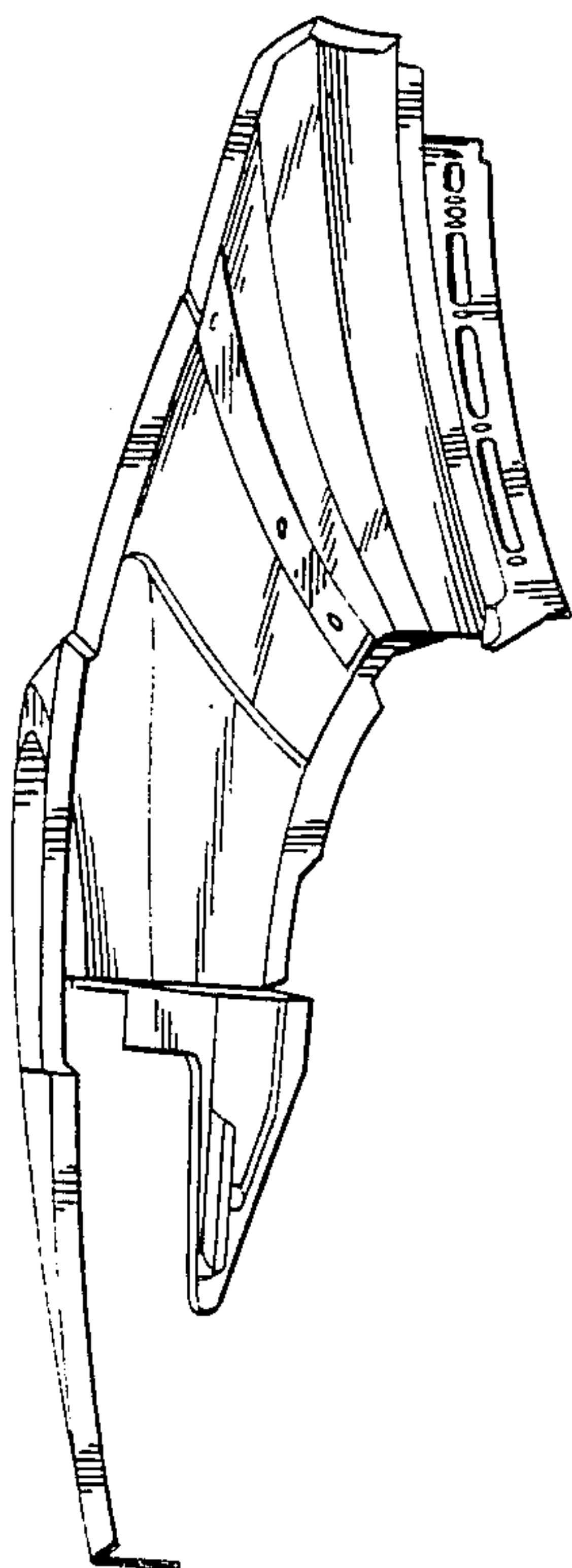

Fig. 7

