

# United States Patent [19]

Pellenz

[11] Patent Number: **Des. 294,474**

[45] Date of Patent: **\*\* Mar. 1, 1988**

[54] **TRAILERABLE CART FOR THE VENDING OF MERCHANDISE**

[76] Inventor: **Charles Pellenz, 840 Dresser St., Cheboygan, Mich. 49721**

[\*\*] Term: **14 Years**

[21] Appl. No.: **725,645**

[22] Filed: **Apr. 22, 1985**

[52] U.S. Cl. .... **D12/102**

[58] Field of Search ..... **D12/102, 105, 104; 296/1 R, 21, 24 R, 168**

[56] **References Cited**

**U.S. PATENT DOCUMENTS**

D. 60,395	2/1922	Brockman	.....	D12/85
D. 89,344	2/1933	Holland	.....	D34/18
D. 132,375	5/1942	Elkus	.....	D12/102
D. 134,573	12/1942	Glascoek, Jr. et al.	.....	D12/102
1,821,593	9/1931	Van Vorst	.....	296/168
1,871,828	8/1932	Van Vorst	.....	296/24 R

2,038,932	4/1936	Haupt	.....	296/24 R
3,492,042	1/1970	Nachtigall, Jr.	.....	296/24 R
3,741,606	6/1973	Grier	.....	D12/104

**FOREIGN PATENT DOCUMENTS**

2724137 11/1978 Fed. Rep. of Germany ..... 296/21

*Primary Examiner*—James M. Gandy  
*Attorney, Agent, or Firm*—Norman B. Rainer

[57] **CLAIM**

The ornamental design for a trailerable cart for the vending of merchandise, as shown and described.

**DESCRIPTION**

FIG. 1 is a perspective view of a trailerable cart for the vending of merchandise showing my new design; FIG. 2 is an end elevation view thereof, the opposite end being a mirror image of that shown except for the omission of the hitch bar; FIG. 3 is a side elevation view thereof, the opposite side being a mirror image of that shown; and FIG. 4 is a top plan view thereof.

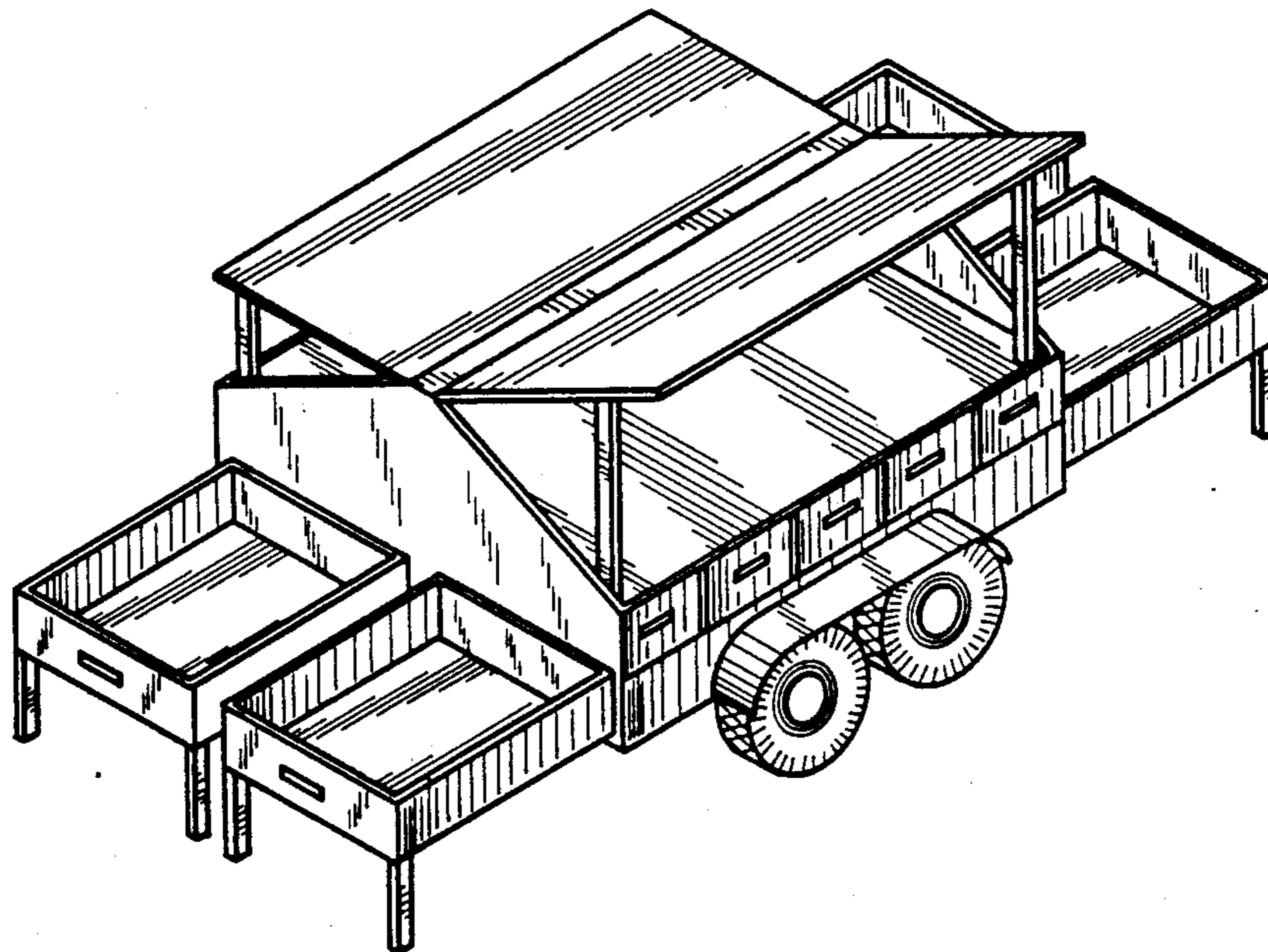

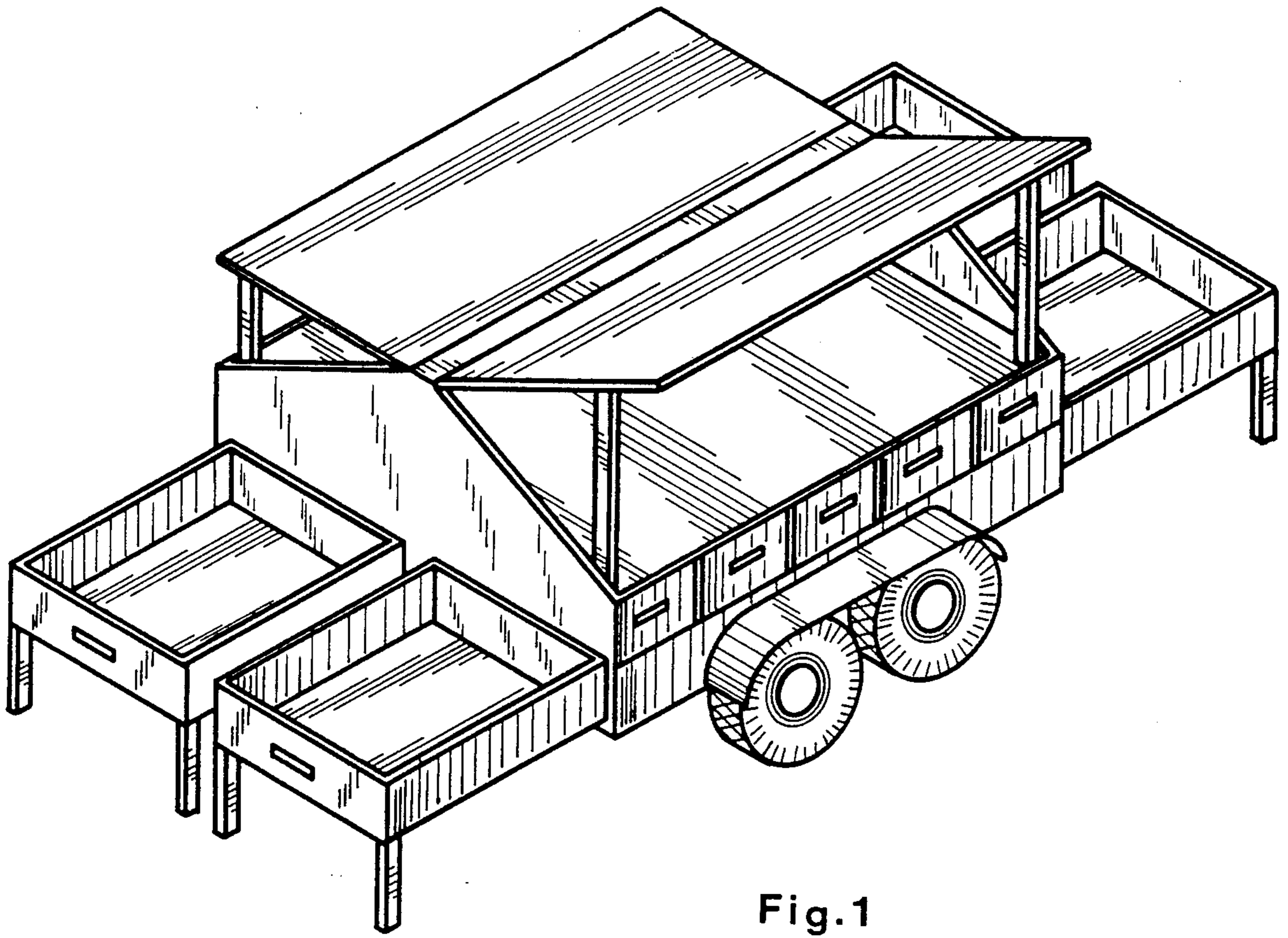

Fig. 1

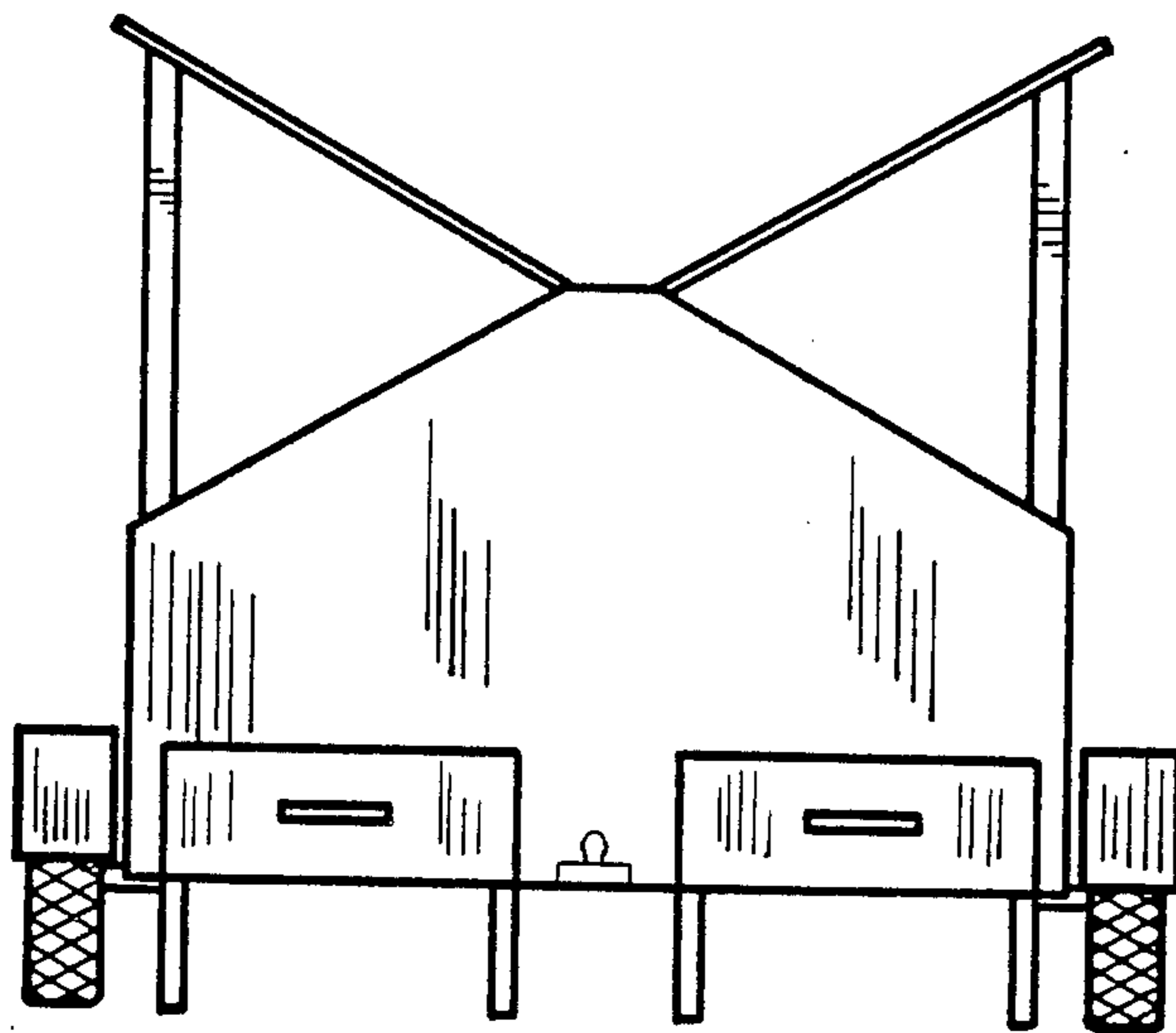

Fig. 2

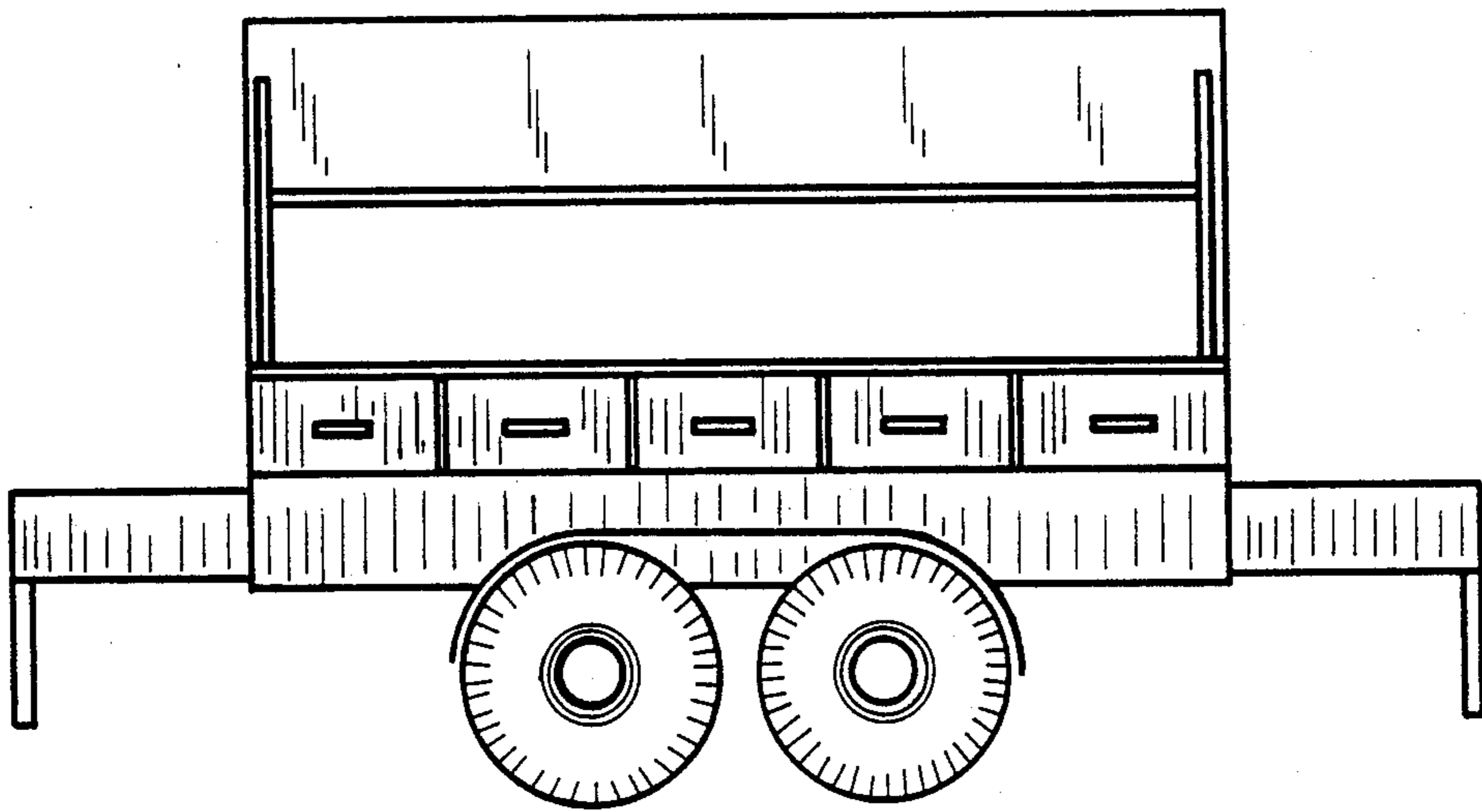

Fig. 3

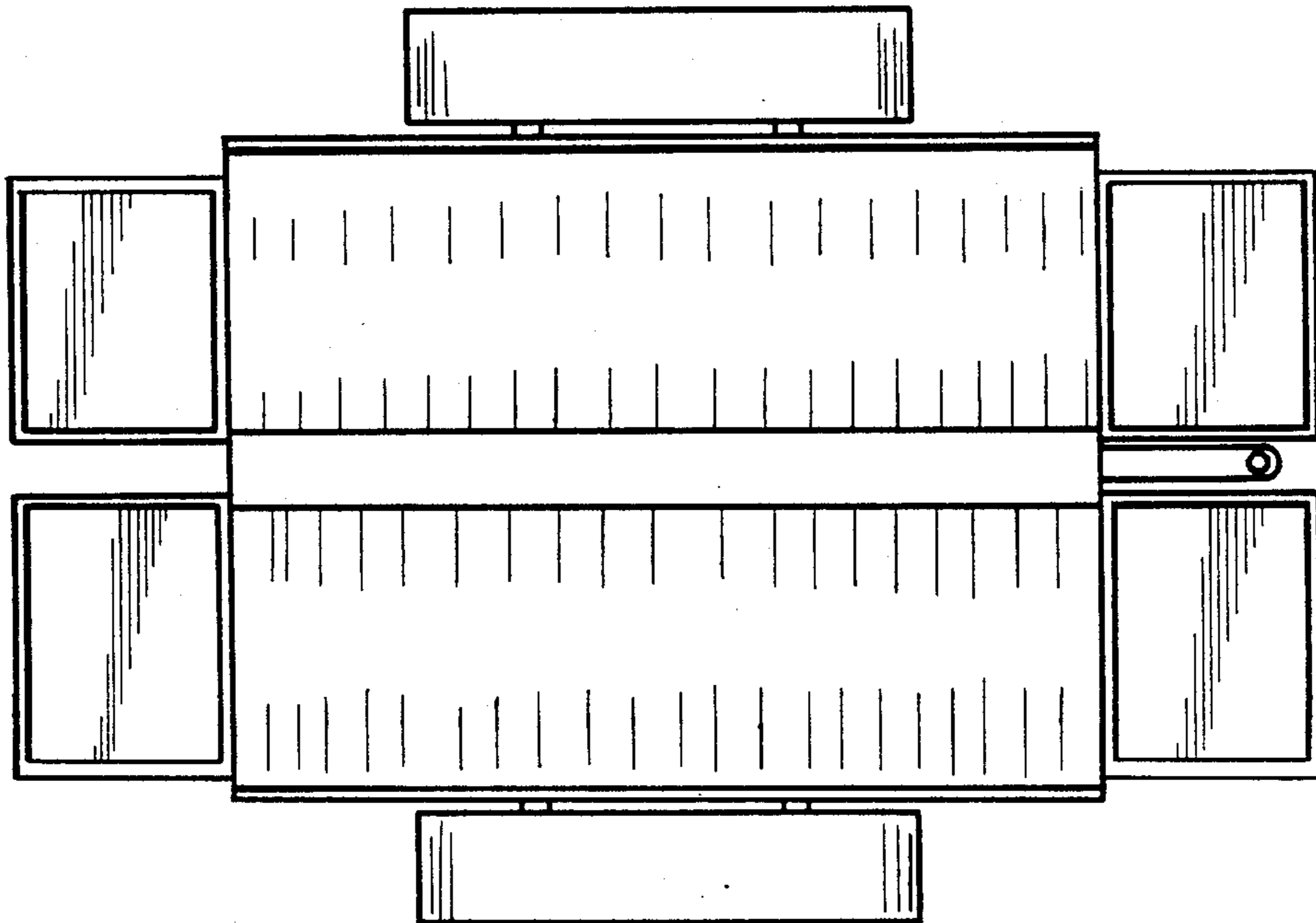

Fig. 4