

[54] REAR COMBINATION LAMP FOR AN
AUTOMOBILE

[75] Inventor: Seiichiro Kitahashi, Toyota, Japan

[73] Assignee: Toyota Jidosha Kabushiki Kaisha,
Toyota, Japan

[**] Term: 14 Years

[21] Appl. No.: 807,477

[22] Filed: Dec. 10, 1985

[52] U.S. Cl. D26/35

[58] Field of Search D26/28-37,
D26/119, 120, 121, 122; 362/61, 80, 82, 83,
326-339

[56] References Cited

U.S. PATENT DOCUMENTS

- D. 271,142 10/1983 Hirasawa .
- D. 271,143 10/1983 Hirakawa .
- D. 279,929 7/1985 Teague .
- D. 285,122 8/1986 Fujita D26/35

FOREIGN PATENT DOCUMENTS

623537 4/1984 Japan D26/35

Primary Examiner—Susan J. Lucas
Attorney, Agent, or Firm—Cushman, Darby & Cushman

[57] CLAIM

The ornamental design for a rear combination lamp for
an automobile, substantially as shown and described.

DESCRIPTION

FIG. 1 is a front perspective view of a rear combination
lamp for an automobile showing my new design;
FIG. 2 is a front elevational view thereof;
FIG. 3 is a rear elevational view thereof;
FIG. 4 is a top plan view thereof;
FIG. 5 is a bottom plan view thereof;
FIG. 6 is a left side elevational view thereof;
FIG. 7 is a right side elevational view thereof;
FIG. 8 is a cross-sectional view taken along line VIII-
—VIII of FIG. 2; and
FIG. 9 is a cross-sectional view taken along line IX—IX
of FIG. 2.

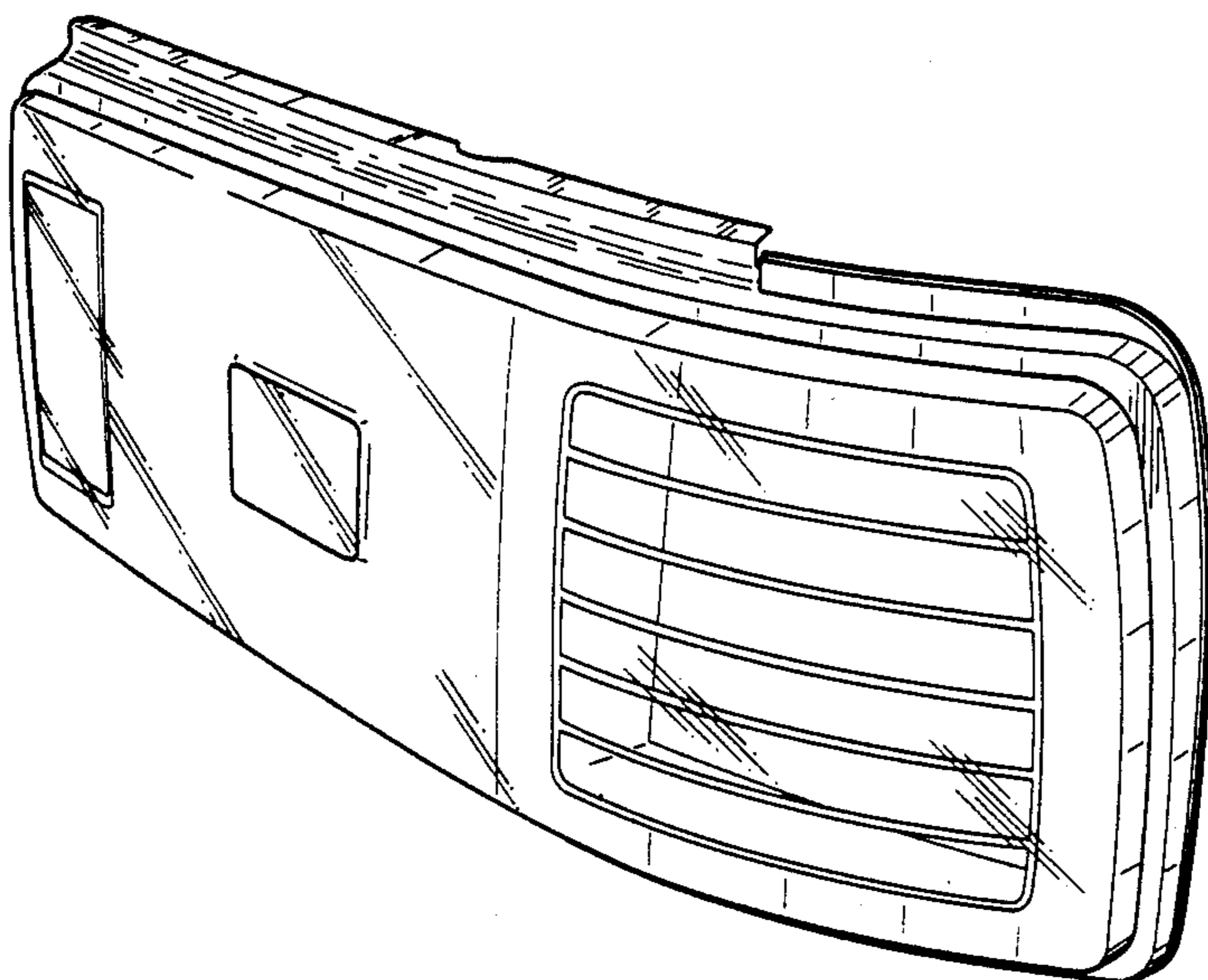

Fig. 1

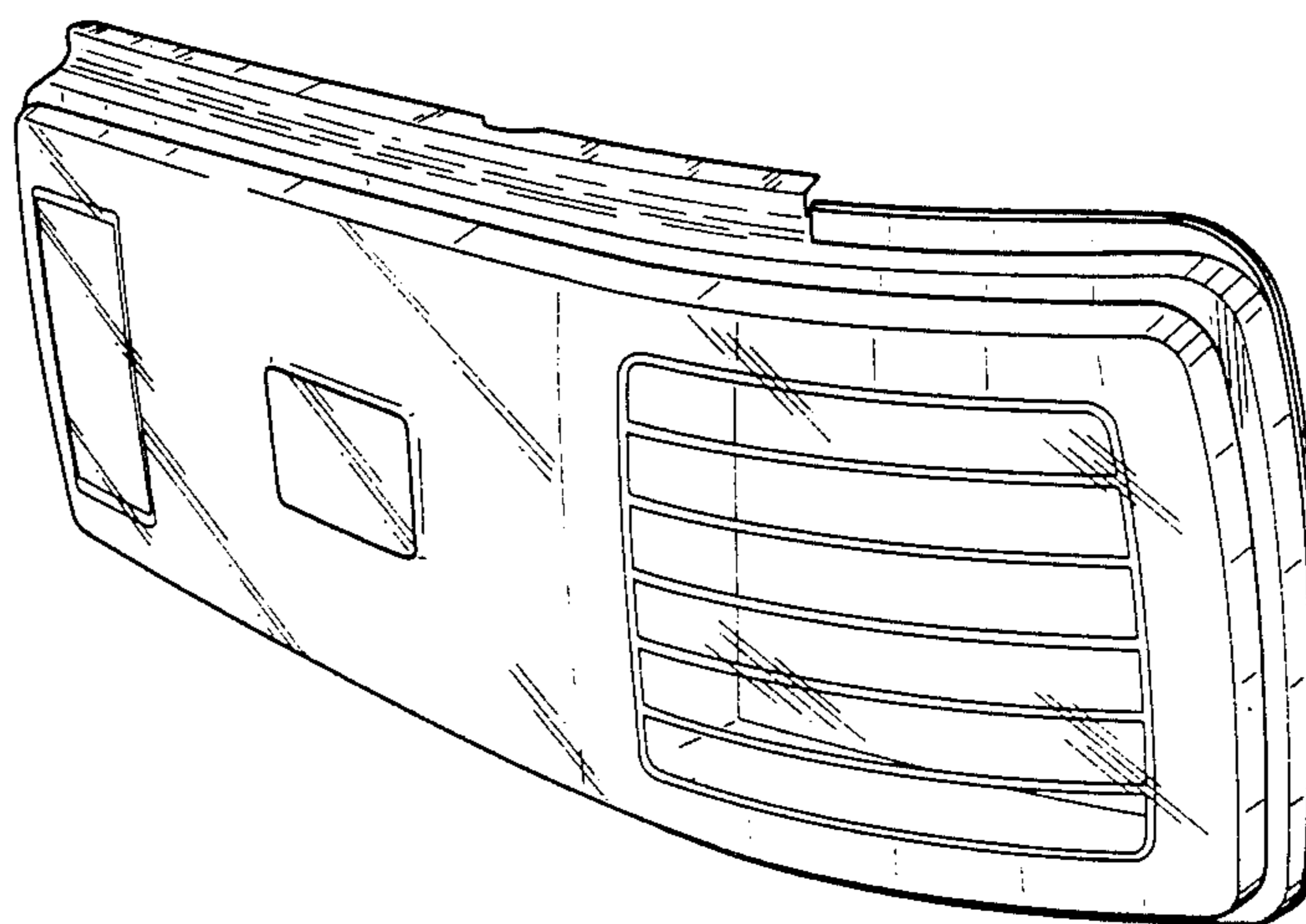

Fig. 2

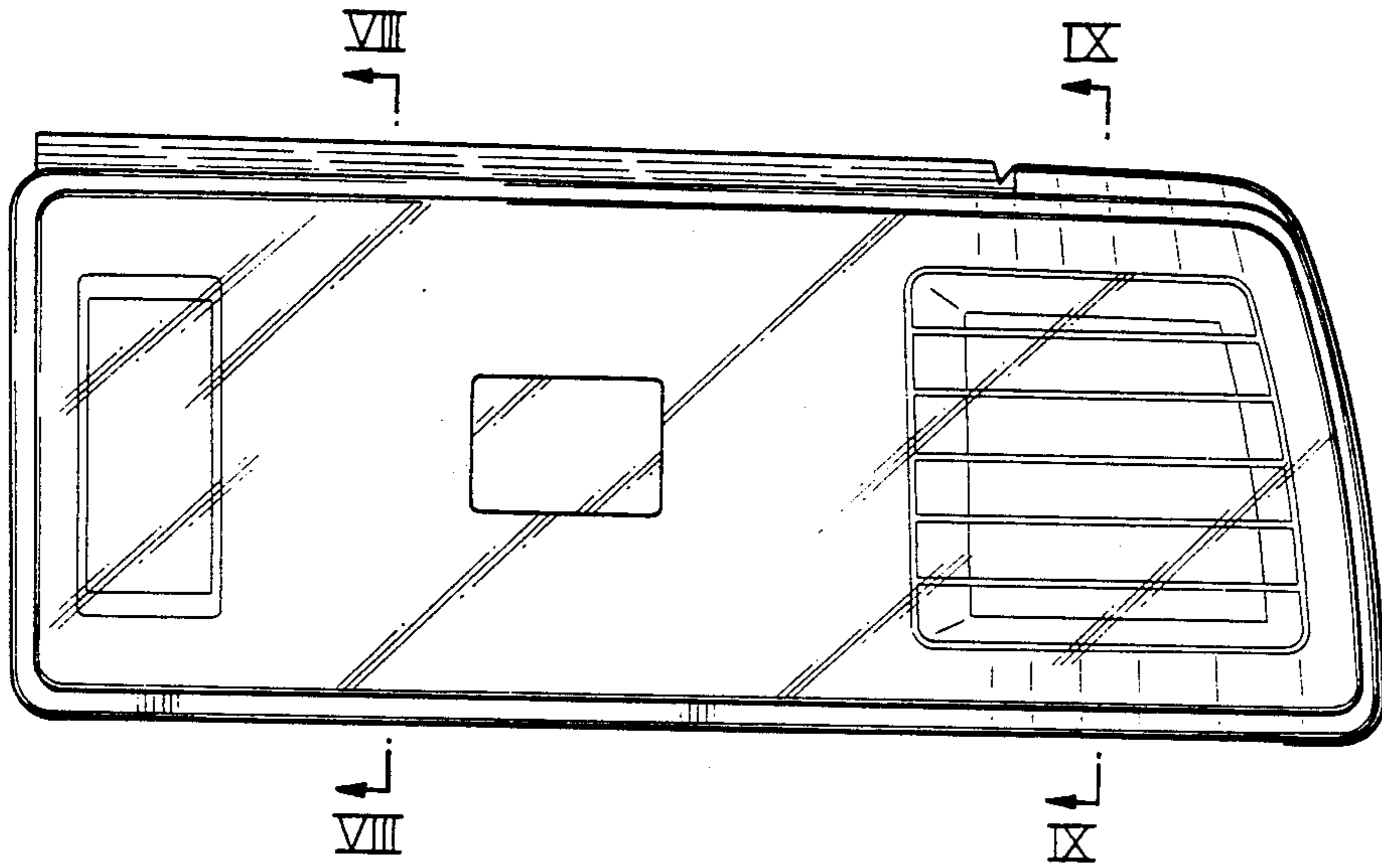

Fig. 3

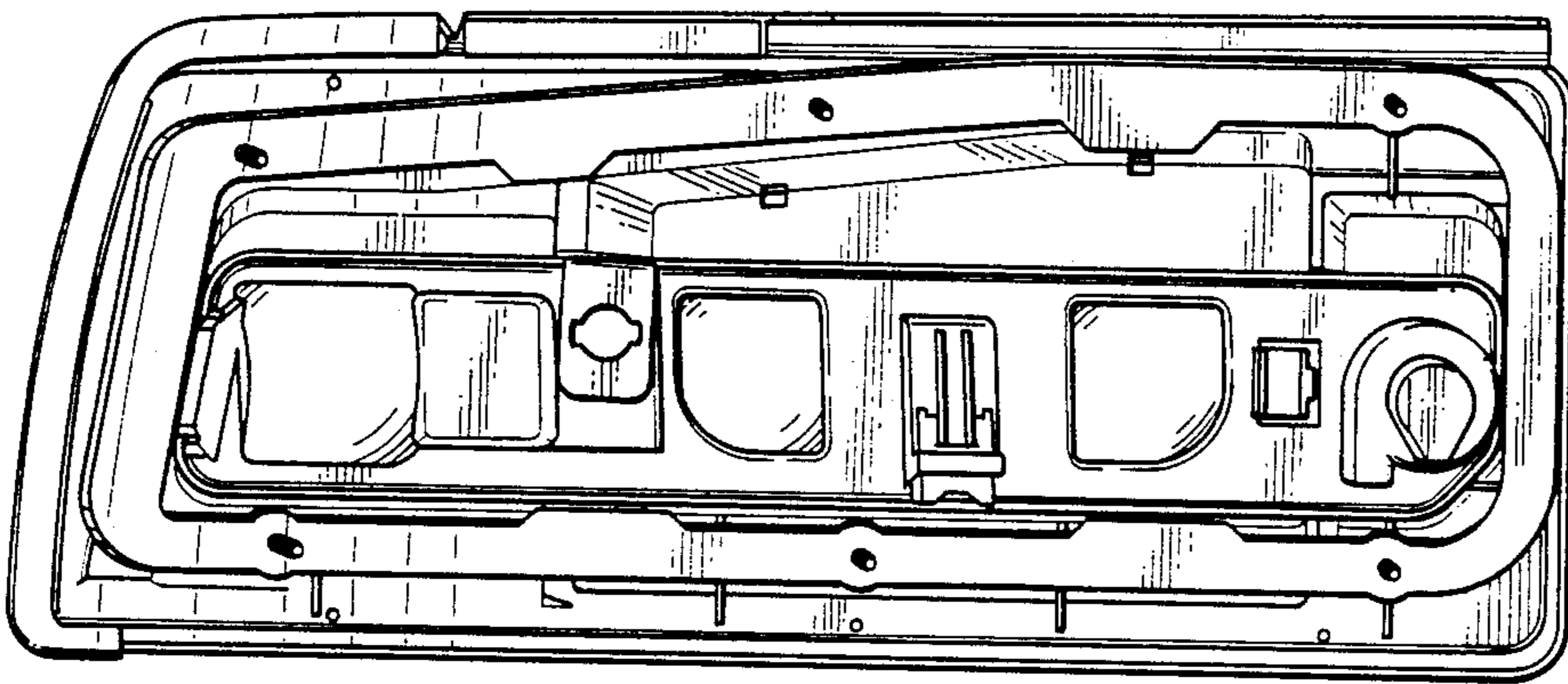

Fig. 4

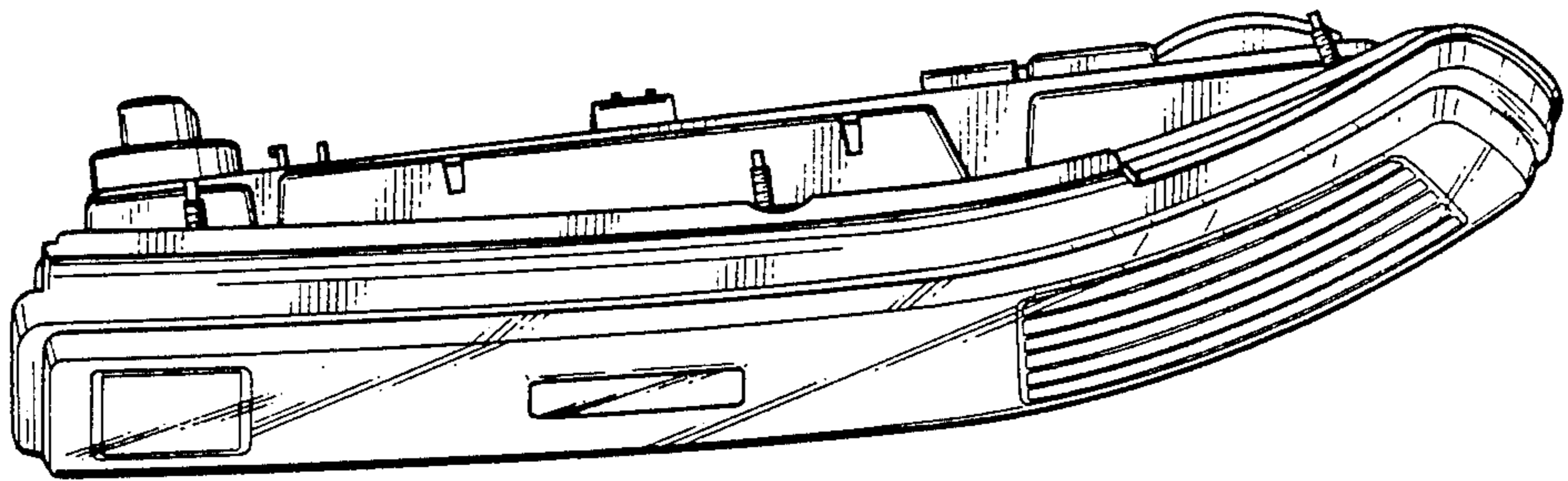

Fig. 5

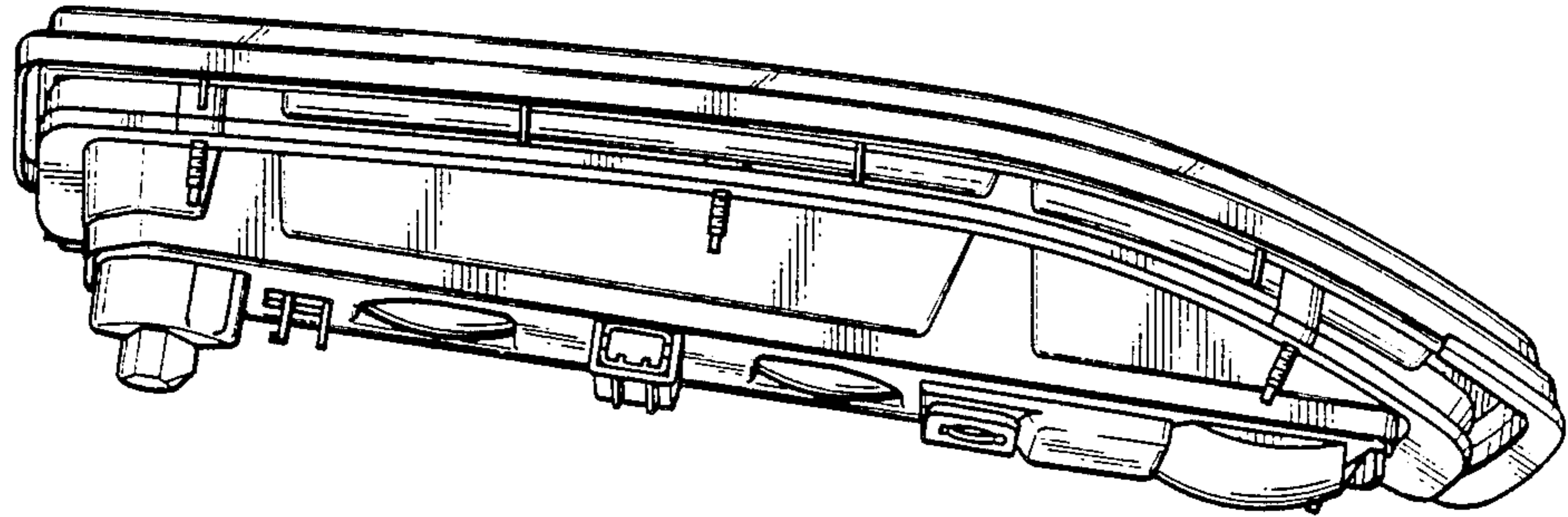

Fig. 6

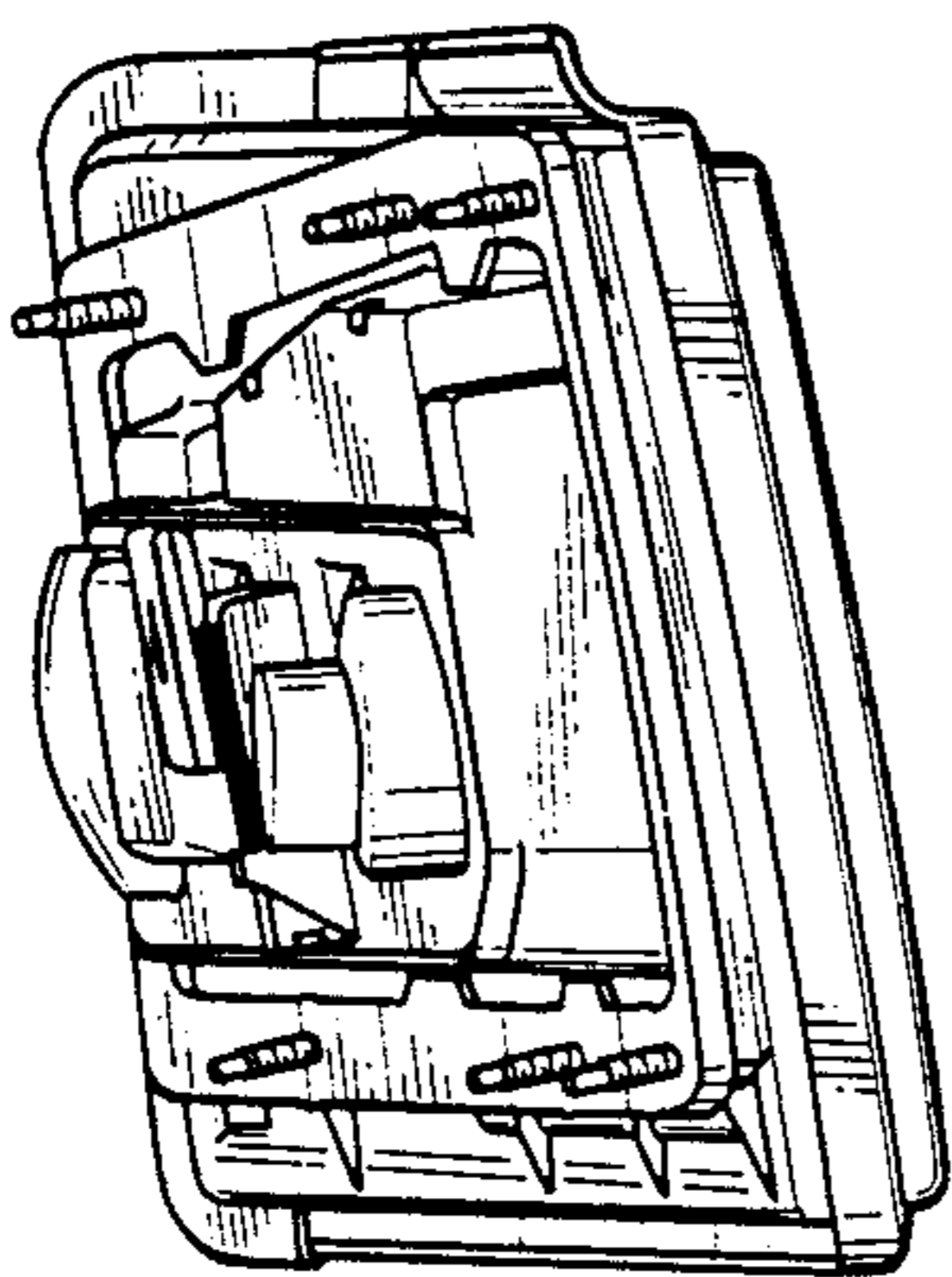

Fig. 7

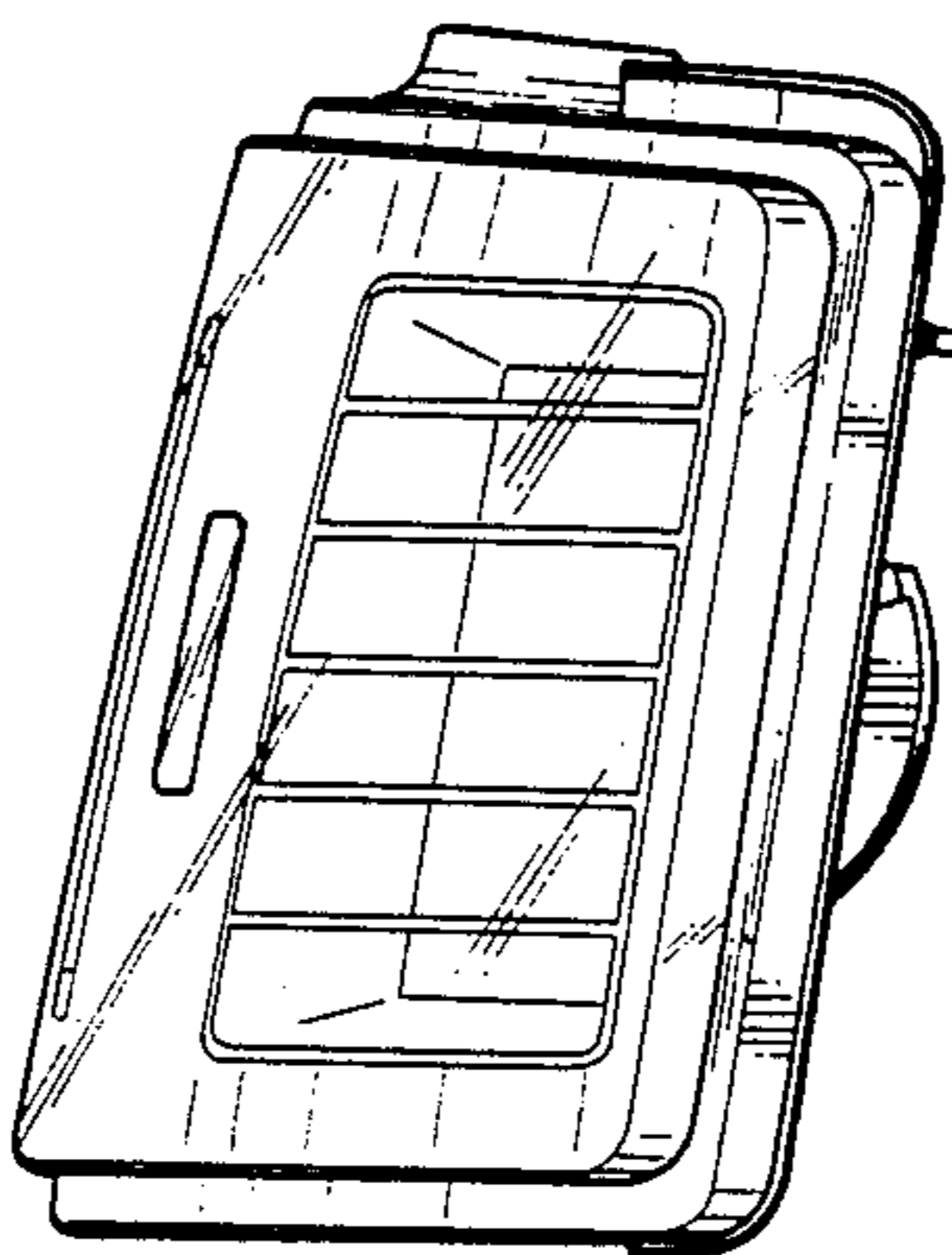

Fig. 8

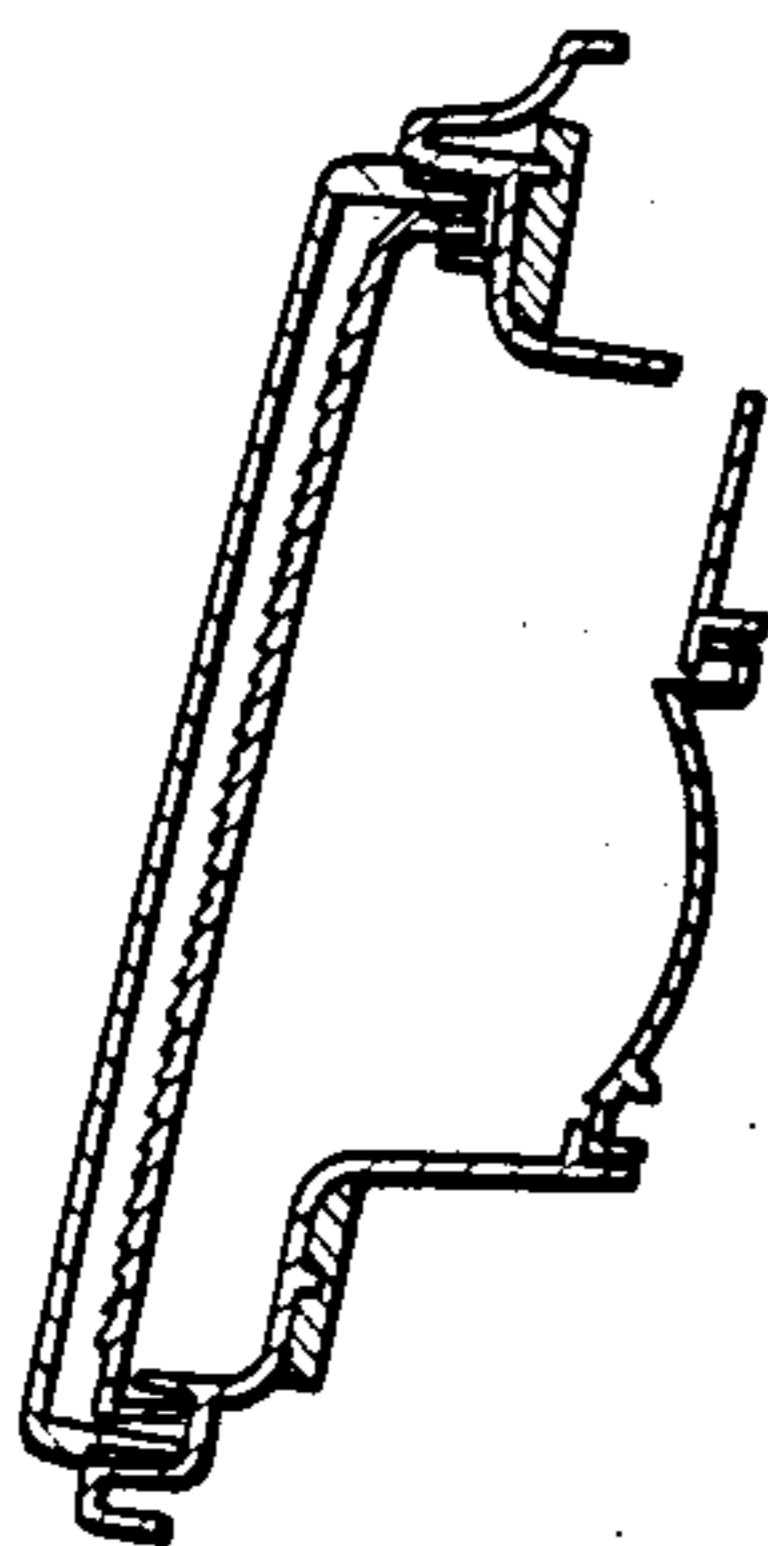

Fig. 9

