

[54] TOY VEHICLE

[75] Inventor: Hiromi Kamikawa, Tokyo, Japan

[73] Assignee: Supertoys Industrial Company Limited, Chai Wan, Hong Kong

[**] Term: 14 Years

[21] Appl. No.: 805,231

[22] Filed: Nov. 15, 1985

[30] Foreign Application Priority Data

May 30, 1985 [GB] United Kingdom 1027079

[52] U.S. Cl. D21/136

[58] Field of Search D21/128-140; 446/431, 465, 466, 468, 469, 470, 471

[56] References Cited

U.S. PATENT DOCUMENTS

- D. 167,906 10/1952 Muller D21/136
- D. 169,541 5/1953 Handler D21/136
- D. 274,740 7/1984 Santaw D21/137

OTHER PUBLICATIONS

Mattel Toys 1984 Catalog, p. 83, #4354, "Split Window".

Primary Examiner—Charles A. Rademaker
Attorney, Agent, or Firm—Banner, Birch, McKie & Beckett

[57] CLAIM

The ornamental design for a toy vehicle, as shown and described.

DESCRIPTION

FIG. 1 is a side elevational view of a toy vehicle, showing my new design, the side opposite being a mirror image;

FIG. 2 is a top plan view thereof;

FIG. 3 is a front elevational view thereof;

FIG. 4 is a rear elevational view thereof;

FIG. 5 is a bottom plan view thereof;

FIG. 6 is a side elevational view with certain components shown in a different position from that shown in FIG. 1; and,

FIG. 7 is a top plan view thereof.

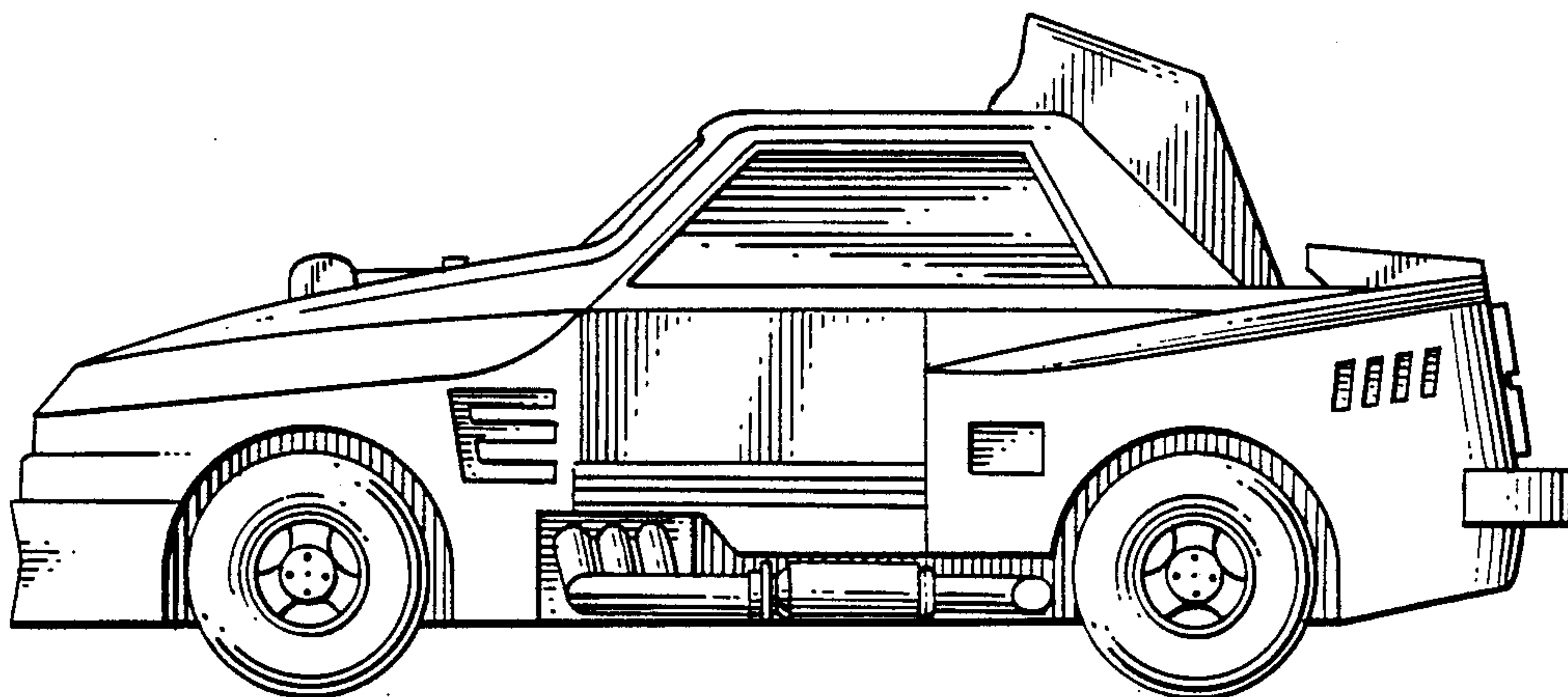

FIG. 1.

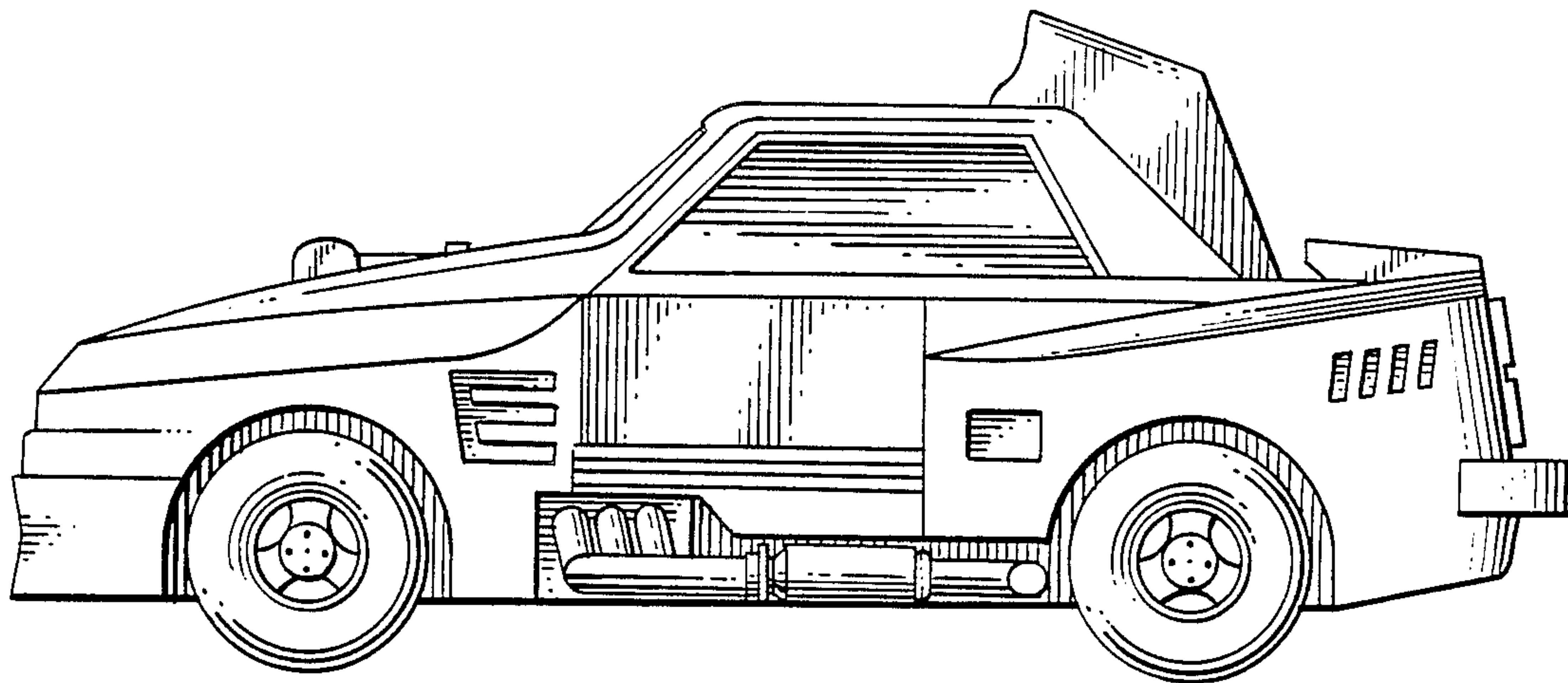

FIG. 2.

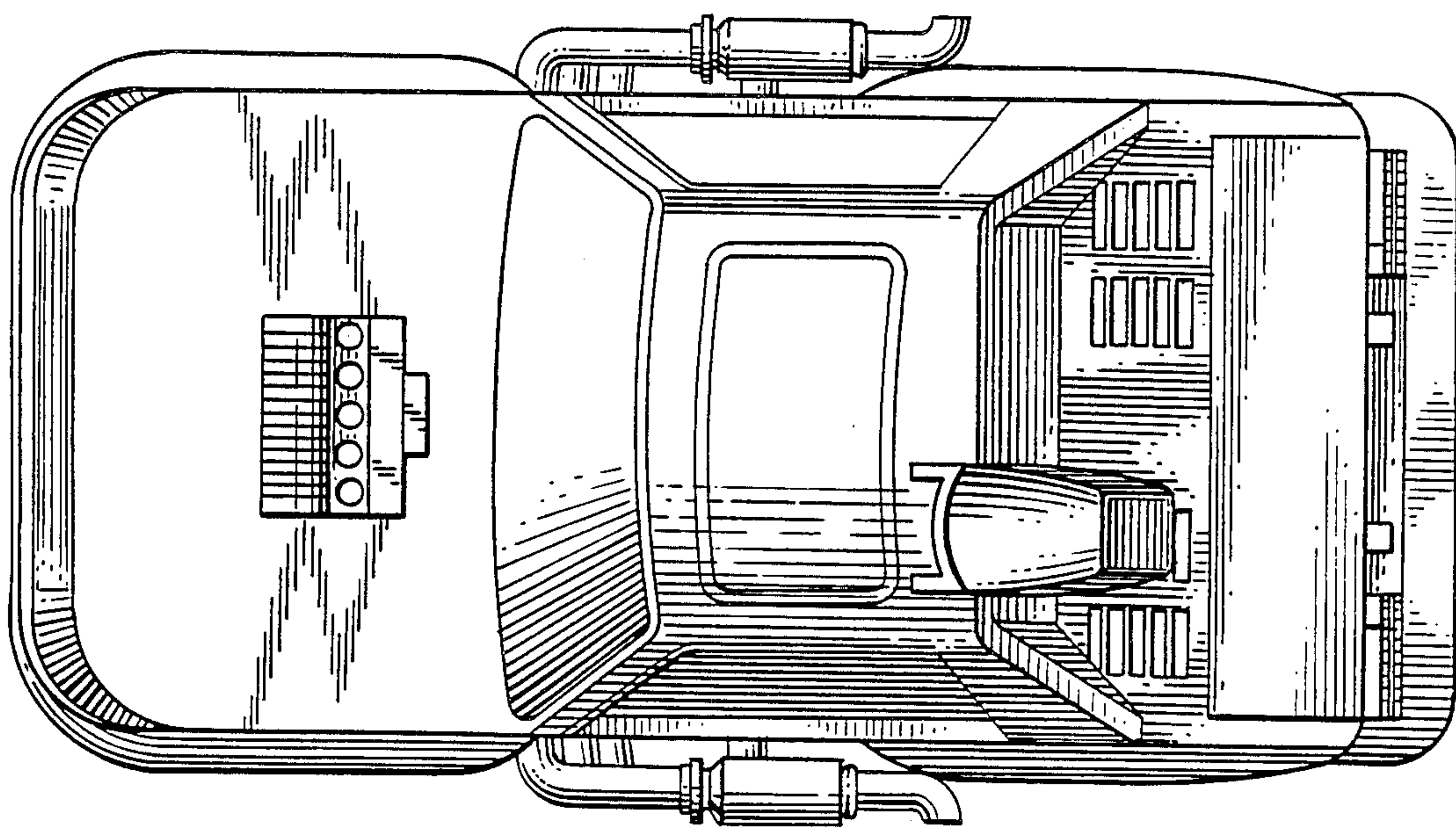

FIG. 3.

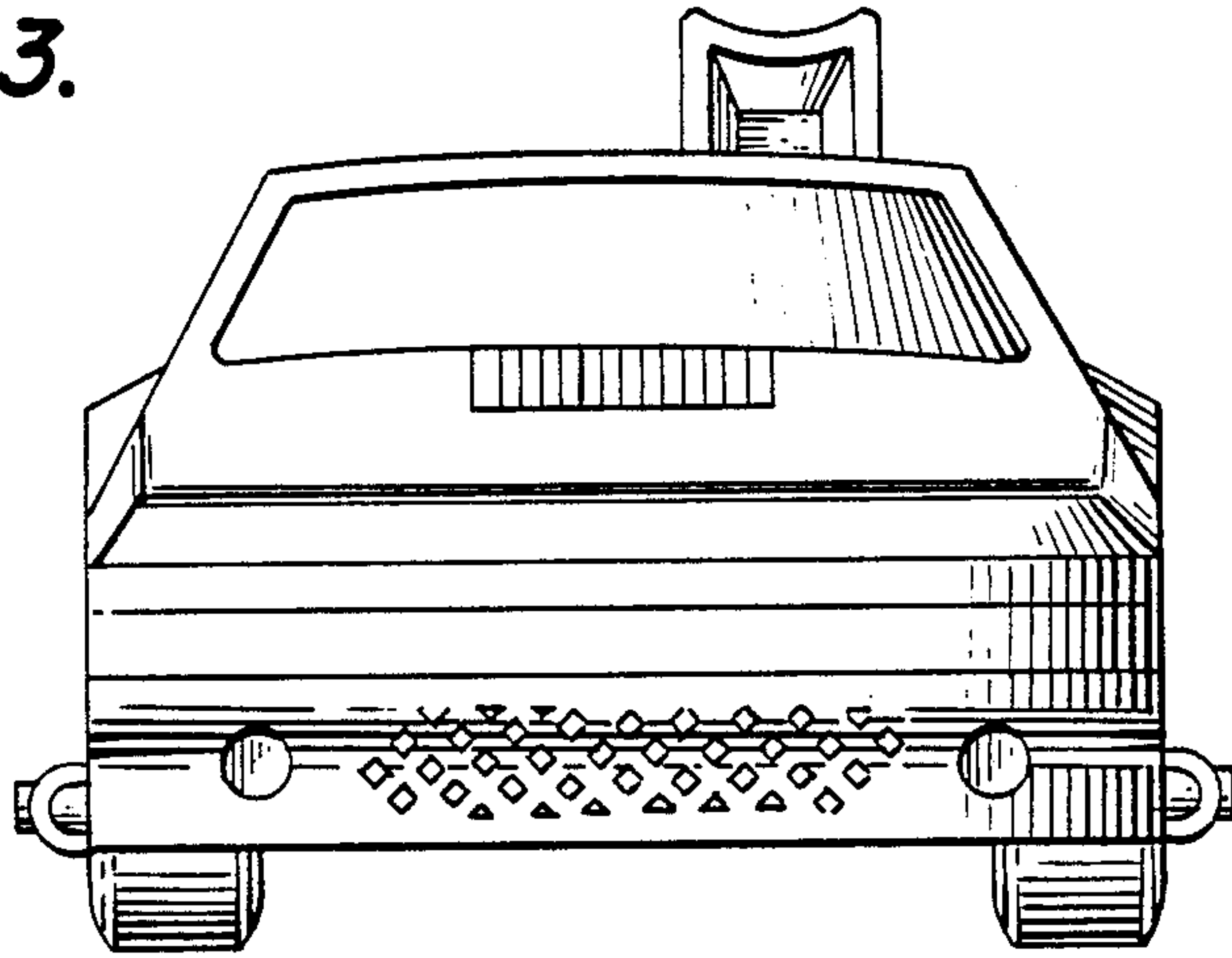

FIG. 4.

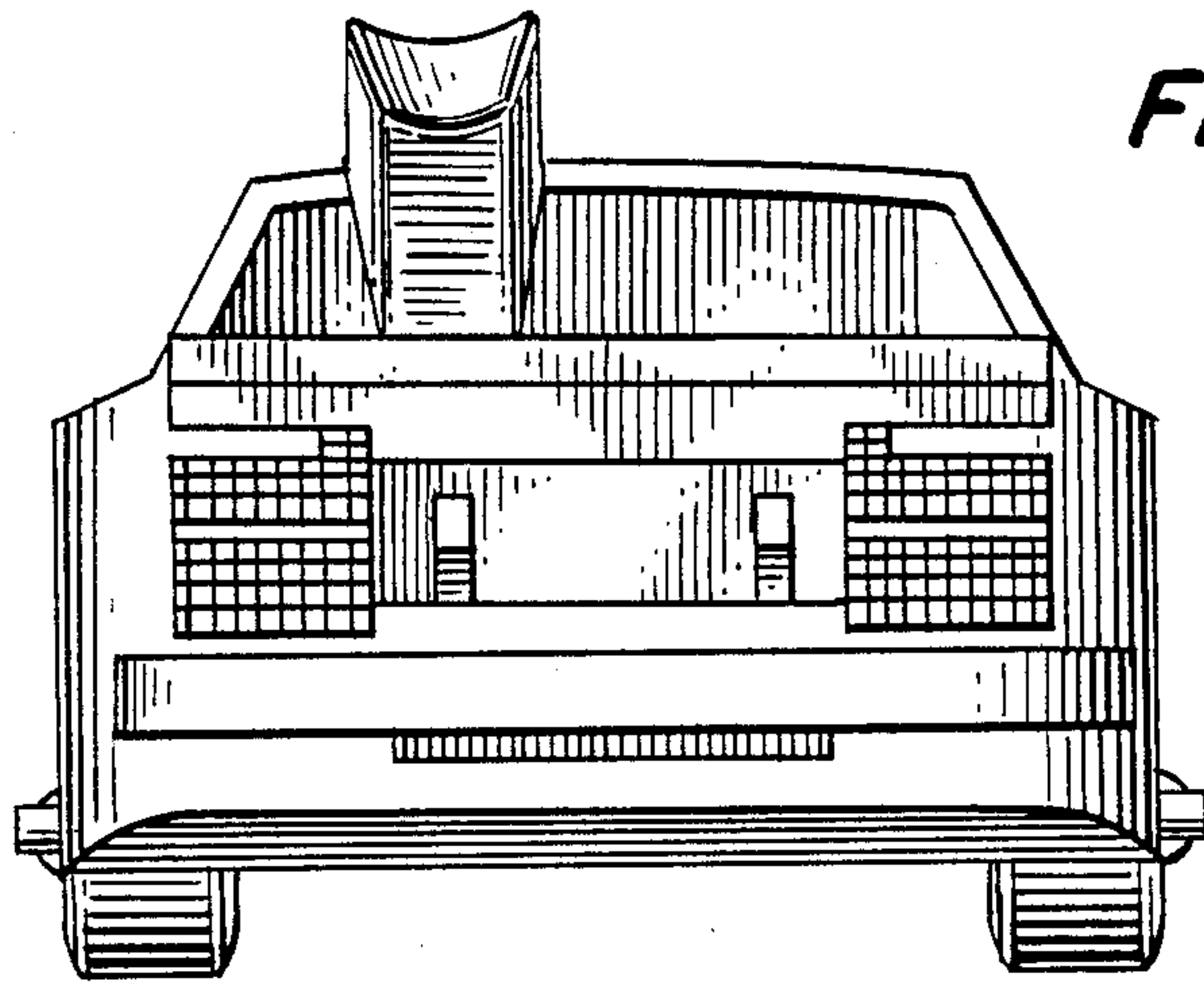

FIG. 5.

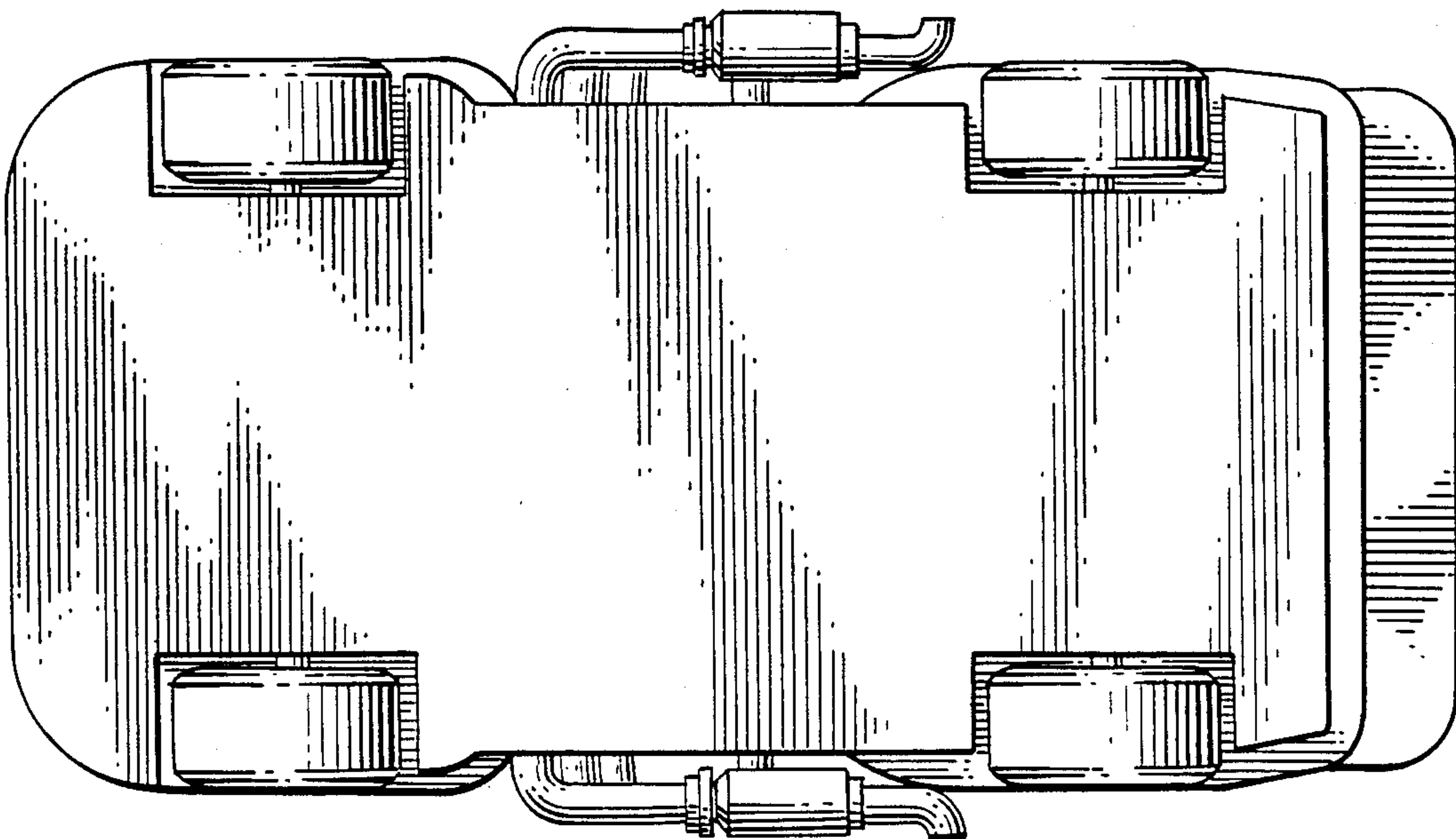

FIG. 6.

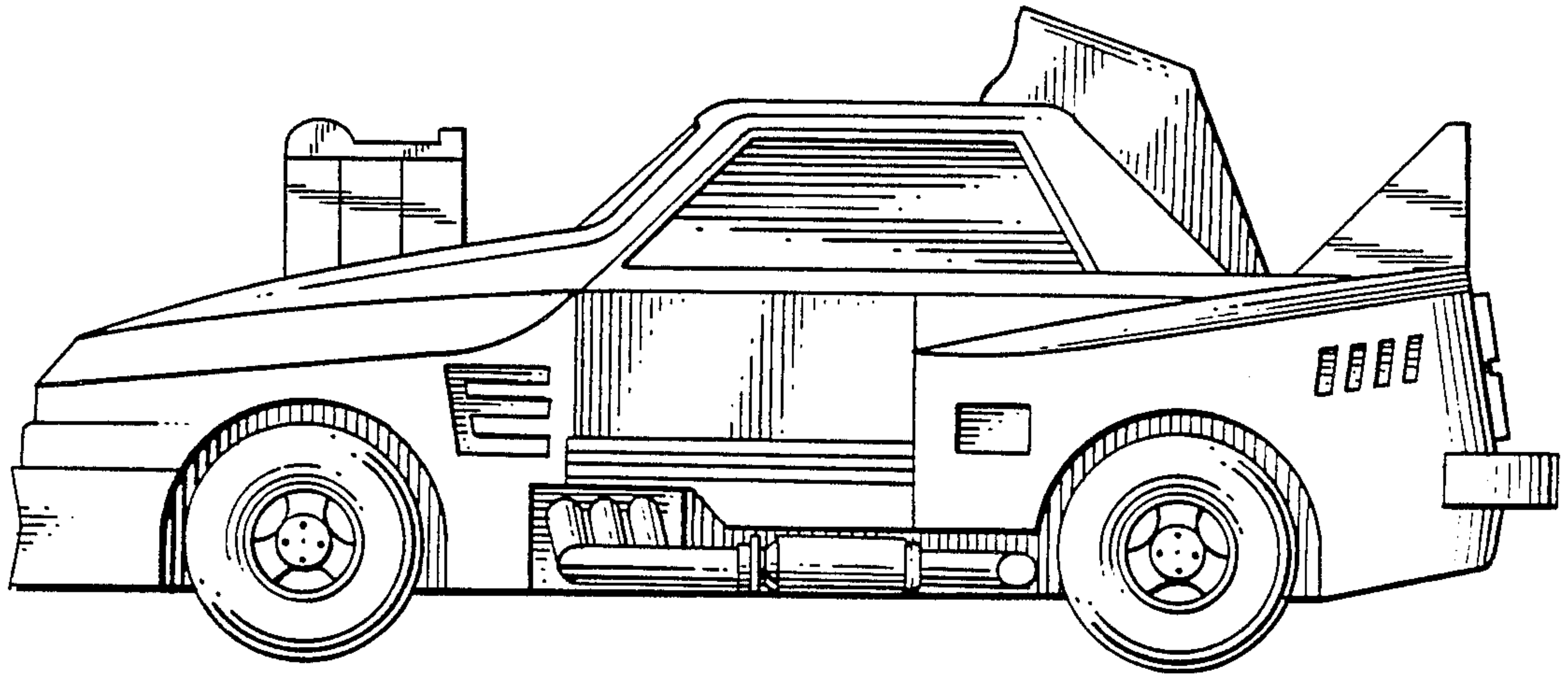

FIG. 7.

