

[54] COMBINED HEAD RAIL, BRACKETS AND TILT ROD FOR VENETIAN BLIND

[76] Inventor: Roland Olofsson, Lyckebobacken 8, 443 00 Lerum, Sweden

[\*\*] Term: 14 Years

[21] Appl. No.: 664,268

[22] Filed: Oct. 24, 1984

[30] Foreign Application Priority Data

Apr. 24, 1984 [SE] Sweden ..... 841318

[52] U.S. Cl. .... D6/580; D6/577

[58] Field of Search ..... D6/575, 577, 580, 581, D6/579; D8/358, 376, 377, 359; 160/166 R, 176 R, 178 R; 248/264

[56] References Cited

U.S. PATENT DOCUMENTS

- D. 103,354 2/1937 Wade et al. .... D6/577
- D. 162,192 2/1951 Lorentzen ..... D6/580
- 2,423,978 7/1947 Hunter ..... 160/178 R

- 2,674,432 4/1954 Lorentzen ..... 248/264
- 4,071,215 1/1978 Marotto ..... 248/264 X
- 4,487,243 12/1984 Debs ..... 160/178 X R
- 4,541,469 9/1985 Dressell ..... 160/178 R X

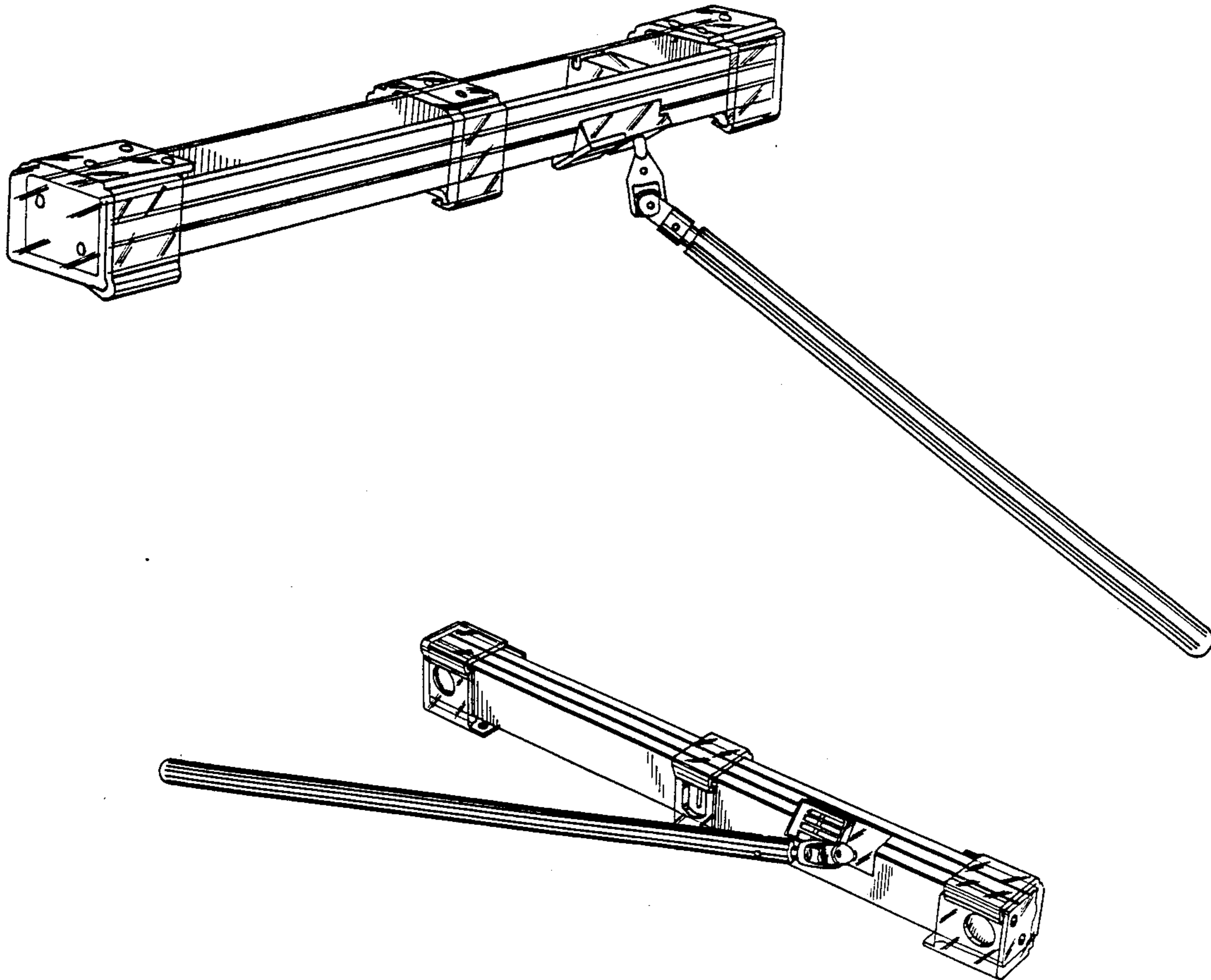
Primary Examiner—Winifred E. Herrmann  
Attorney, Agent, or Firm—Cushman, Darby & Cushman

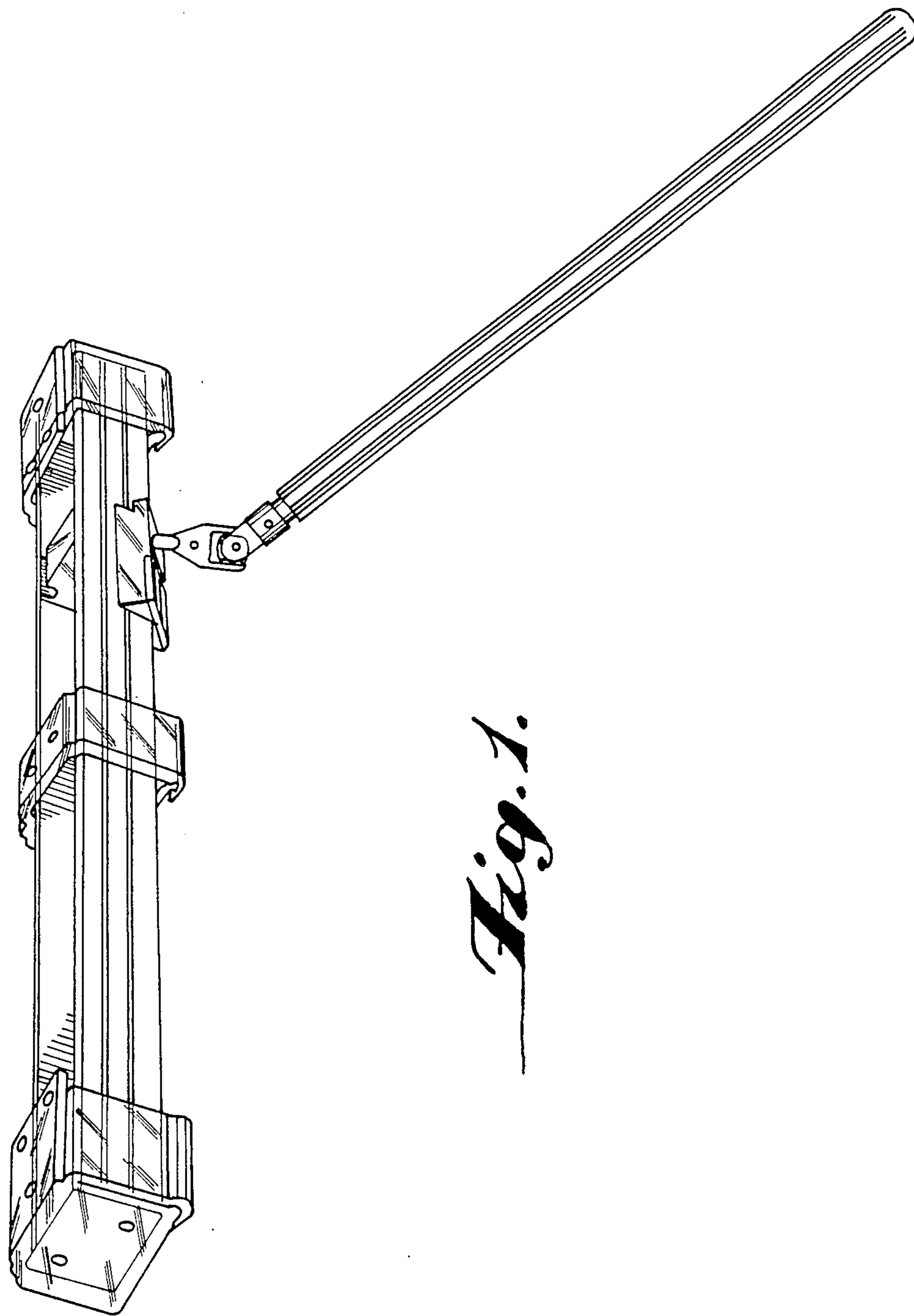
[57] CLAIM

The ornamental design for my combined head rail, brackets and tilt rod for venetian blind, as shown and described hereinbefore.

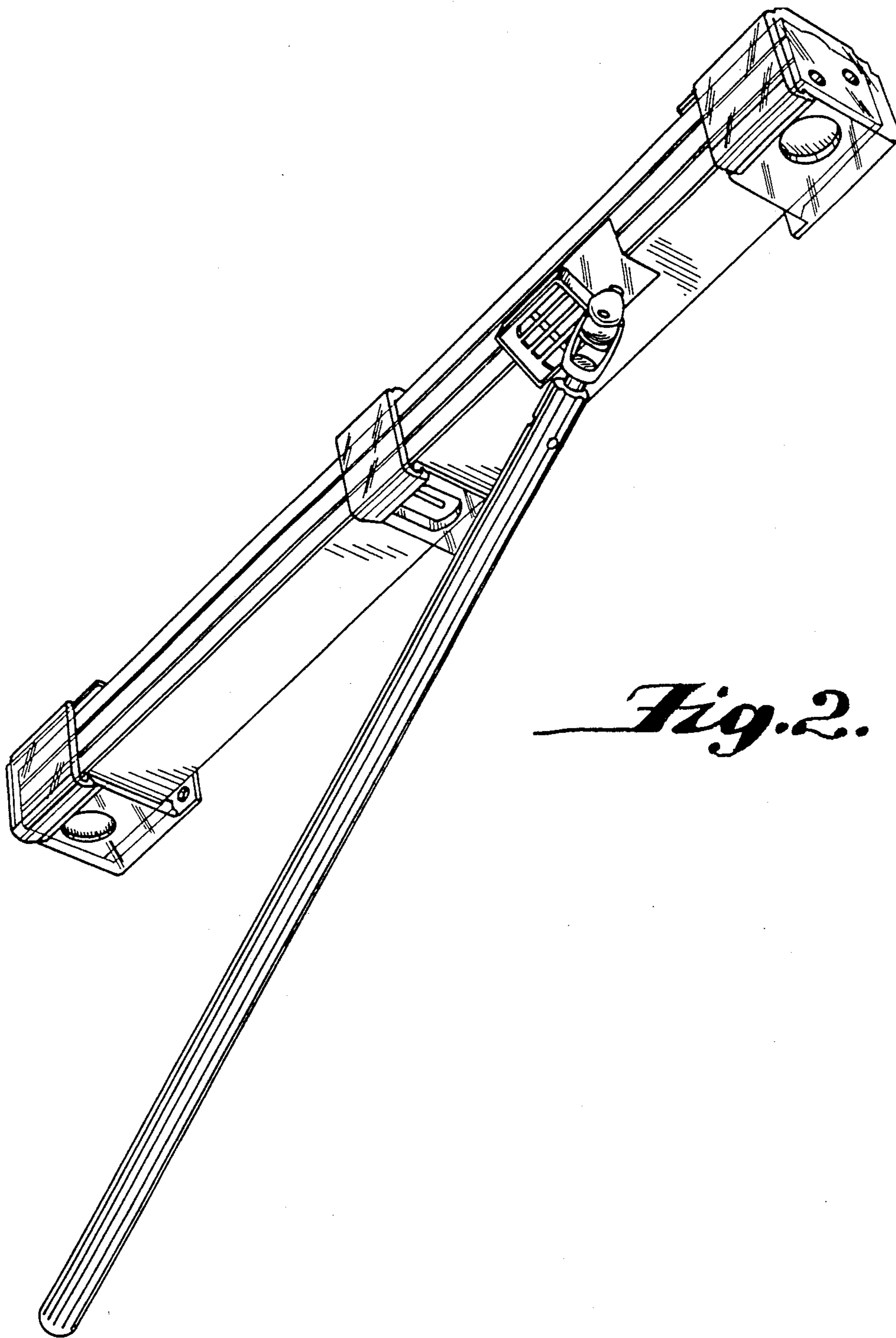
DESCRIPTION

FIG. 1 is a top, front and left end perspective view of a combined head rail, brackets and tilt rod for venetian blind showing my new design;  
 FIG. 2 is a front, bottom and right end perspective view thereof;  
 FIG. 3 is a rear, and right end perspective view thereof;  
 FIG. 4 is a right end elevational view thereof; and  
 FIG. 5 is a left end elevational view thereof.  
 All components except for the tilt rod preferably being manufactured from a transparent plastic material.

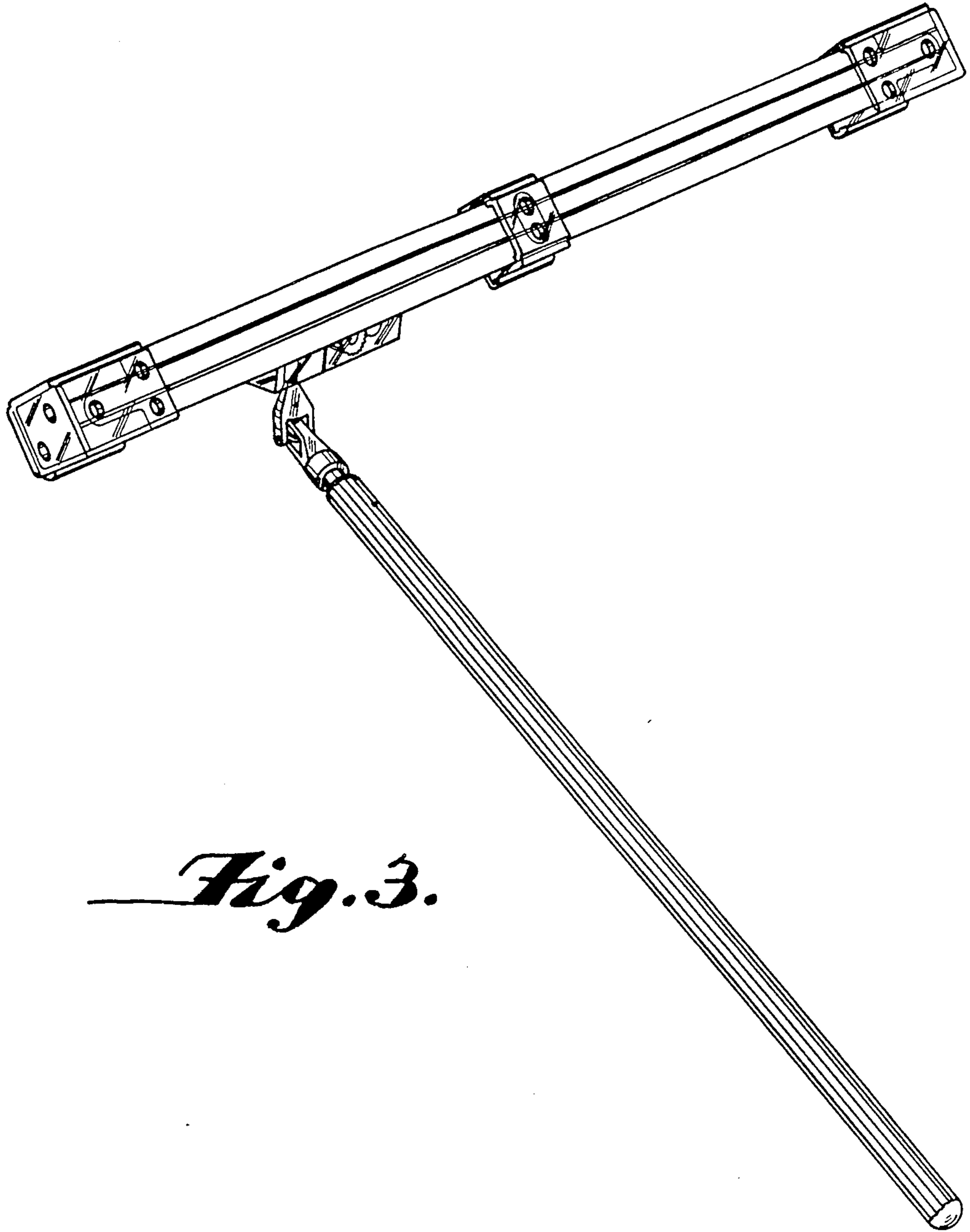




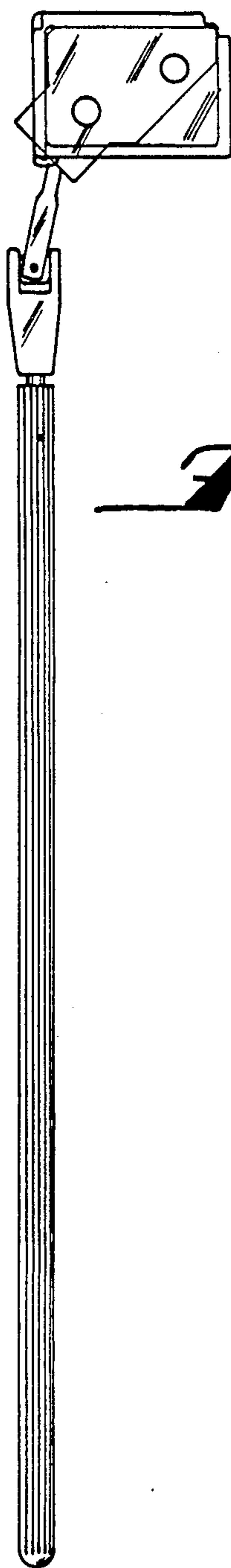
*Fig. 1.*



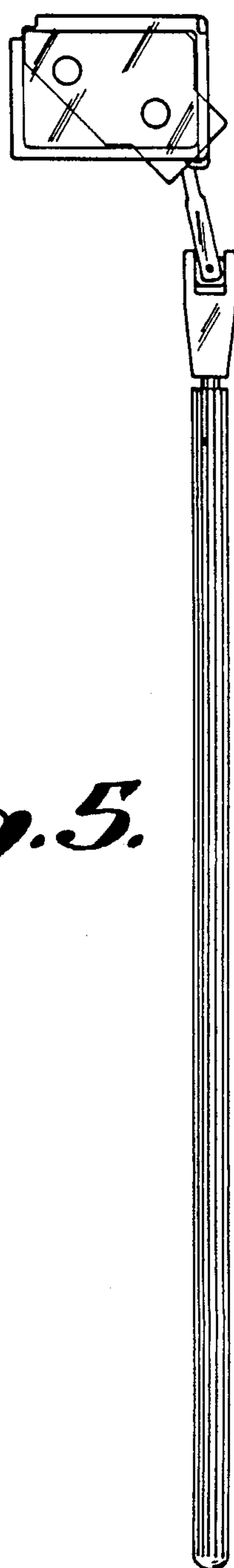
*Fig. 2.*



*Fig. 3.*



*Fig. 4.*



*Fig. 5.*