

United States Patent [19]

Morris

[11] Patent Number: **Des. 294,272**

[45] Date of Patent: **** Feb. 16, 1988**

[54] **ADVERTISING DISPLAY APPARATUS**

[76] Inventor: **Stanley Morris, 13 Woodside Rd.,
Springfield, N.J. 07041**

[**] Term: **14 Years**

[21] Appl. No.: **804,699**

[22] Filed: **Nov. 13, 1985**

[52] U.S. Cl. **D20/19; D7/52;
D20/21**

[58] Field of Search **211/49, 74; D7/52-58;
D20/10, 19, 21; D19/75; 40/10 R, 10 D, 16, 19,
584, 611**

[56] **References Cited**

U.S. PATENT DOCUMENTS

D. 156,670	12/1949	Runnels	D7/55
D. 157,446	2/1950	Smith et al.	D7/52
D. 170,650	10/1953	McHine	D7/52
D. 184,163	12/1958	Bloomfield	D7/52

D. 195,270	5/1963	Gant	D7/52
D. 276,628	12/1984	Morris	D20/19
165,147	7/1875	Baldwin	40/10 D
2,000,419	5/1935	Sarber	40/10 D
3,364,600	1/1968	Patterson	40/611 X
4,432,151	2/1984	Morris	40/10 D
4,505,059	3/1985	Morris	40/10 D

Primary Examiner—Catherine E. Kemper
Attorney, Agent, or Firm—Jeffrey Michael Morris

[57] **CLAIM**

The ornamental design for an advertising display apparatus, as shown.

DESCRIPTION

FIG. 1 is a perspective view of an advertising display apparatus, showing my new design;
FIG. 2 is a front elevational view thereof;
FIG. 3 is a top plan view thereof;
FIG. 4 is a bottom plan view thereof;
FIG. 5 is an end elevational view thereof;
FIG. 6 is an end elevational view thereof;

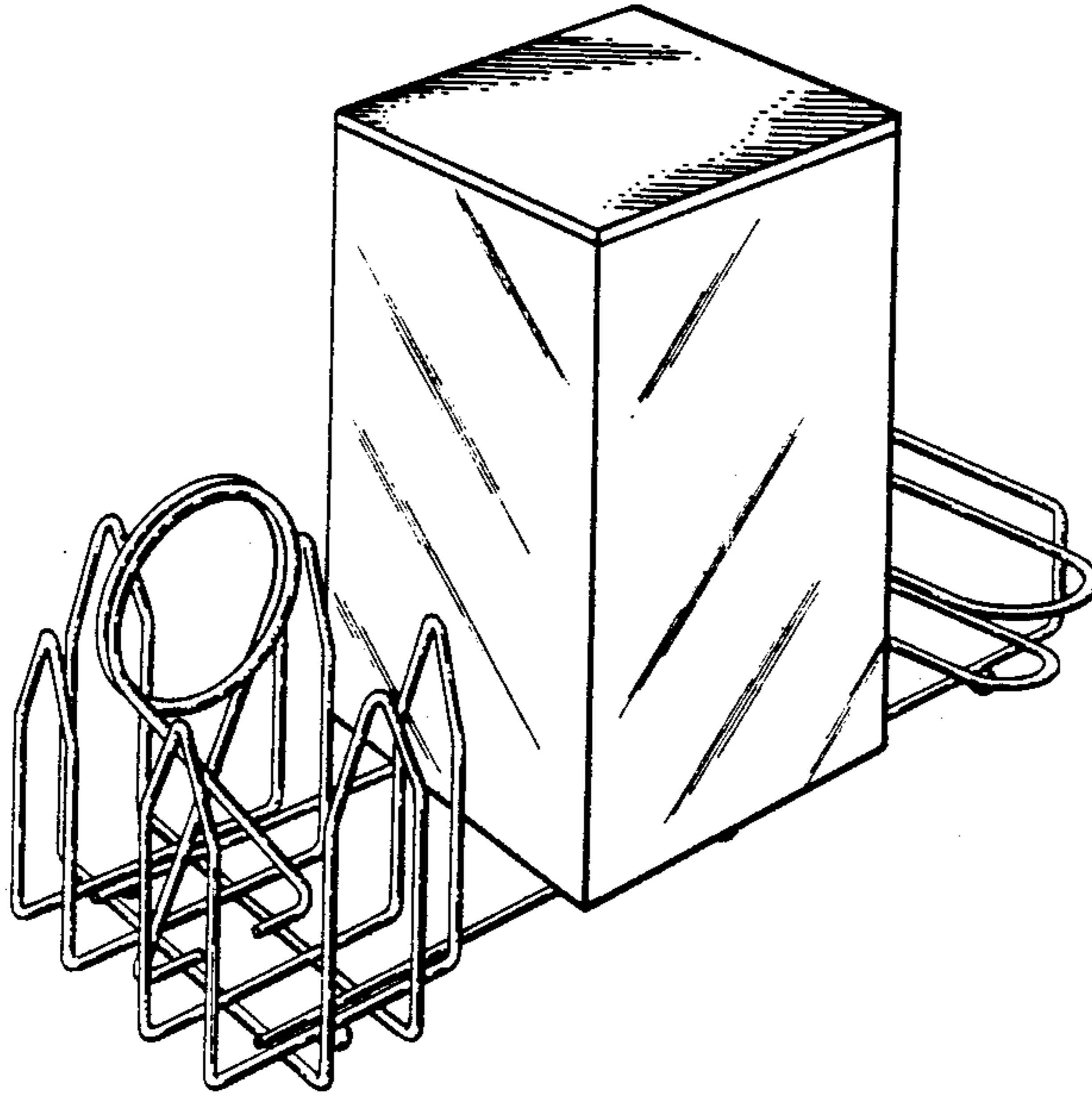

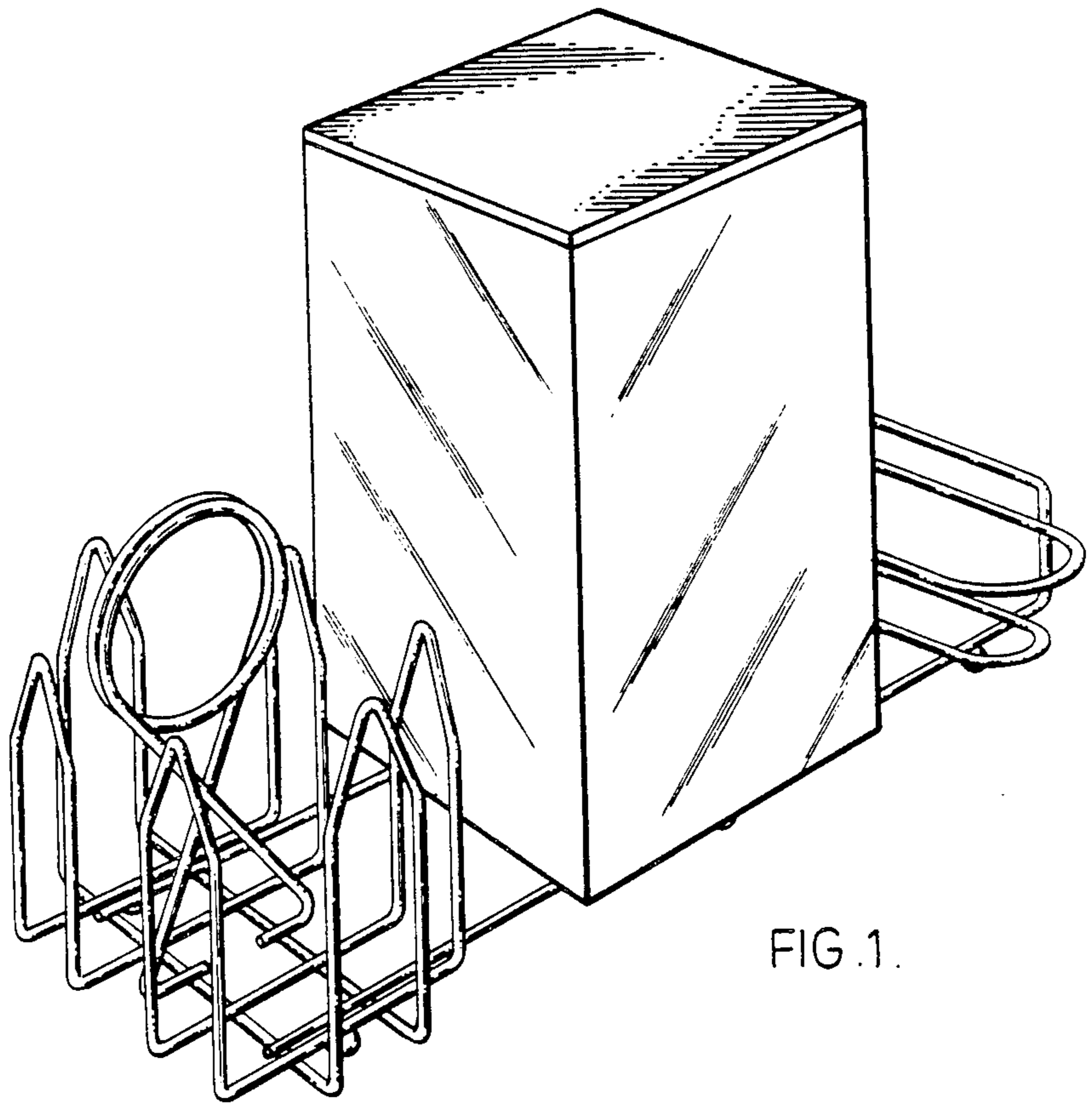

FIG. 1.

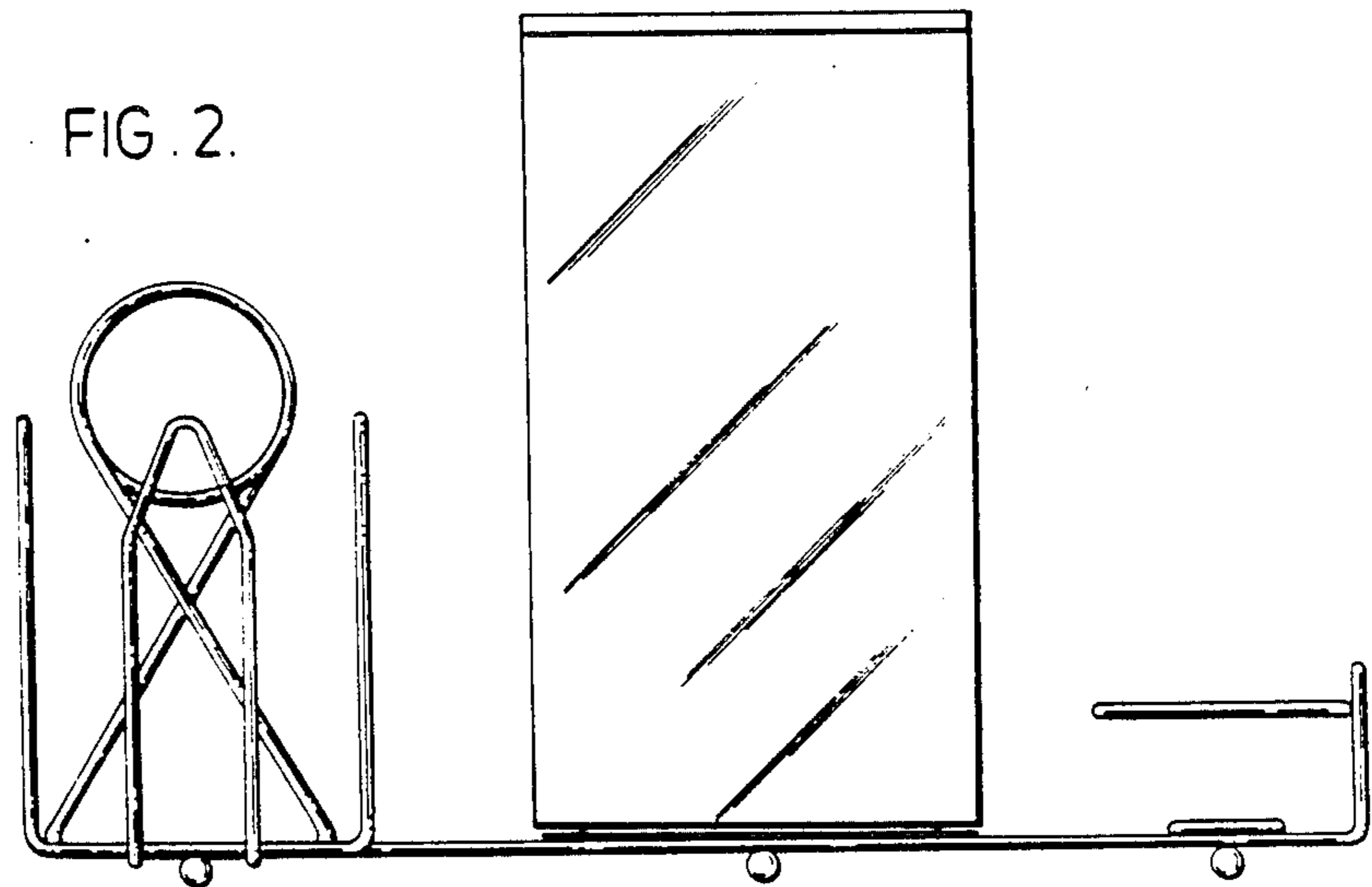

FIG. 2.

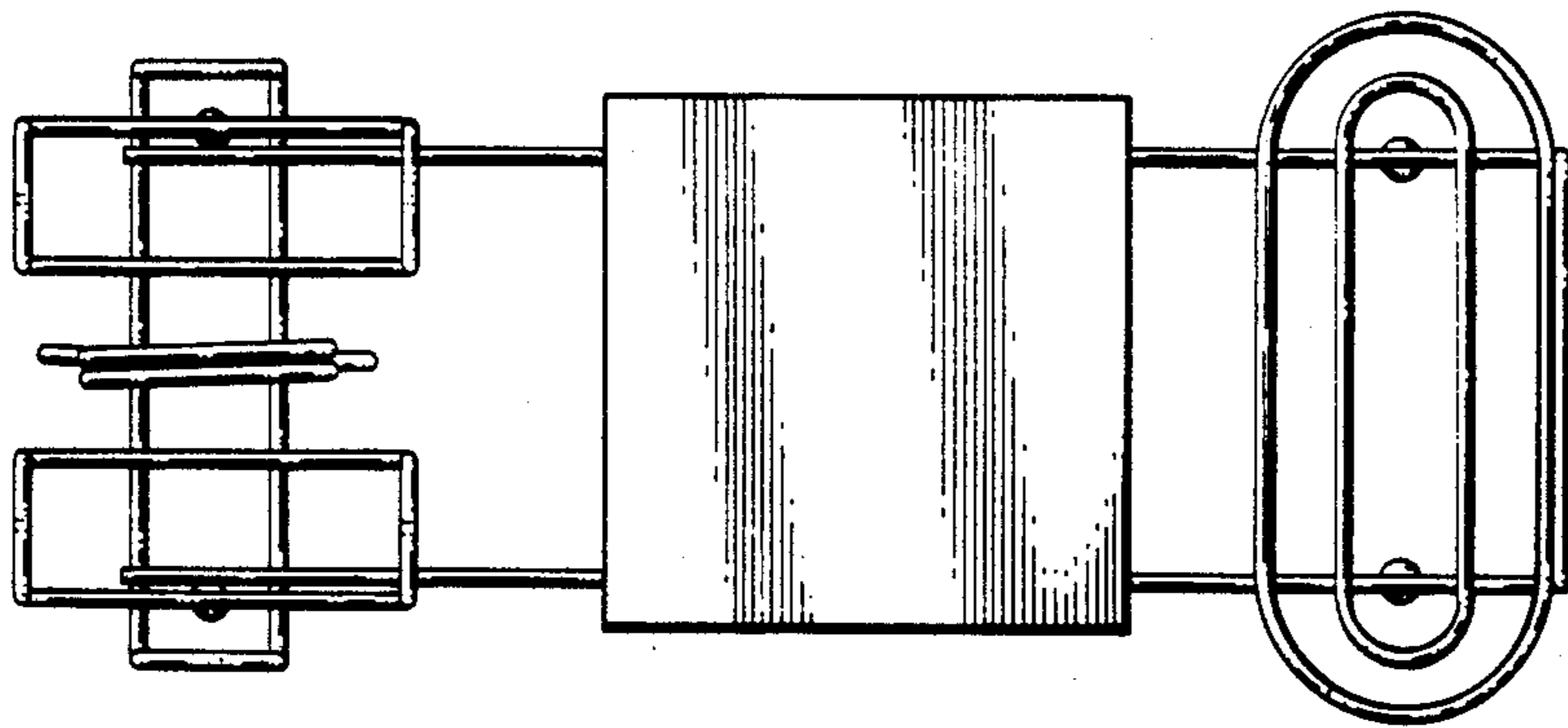

FIG. 3.

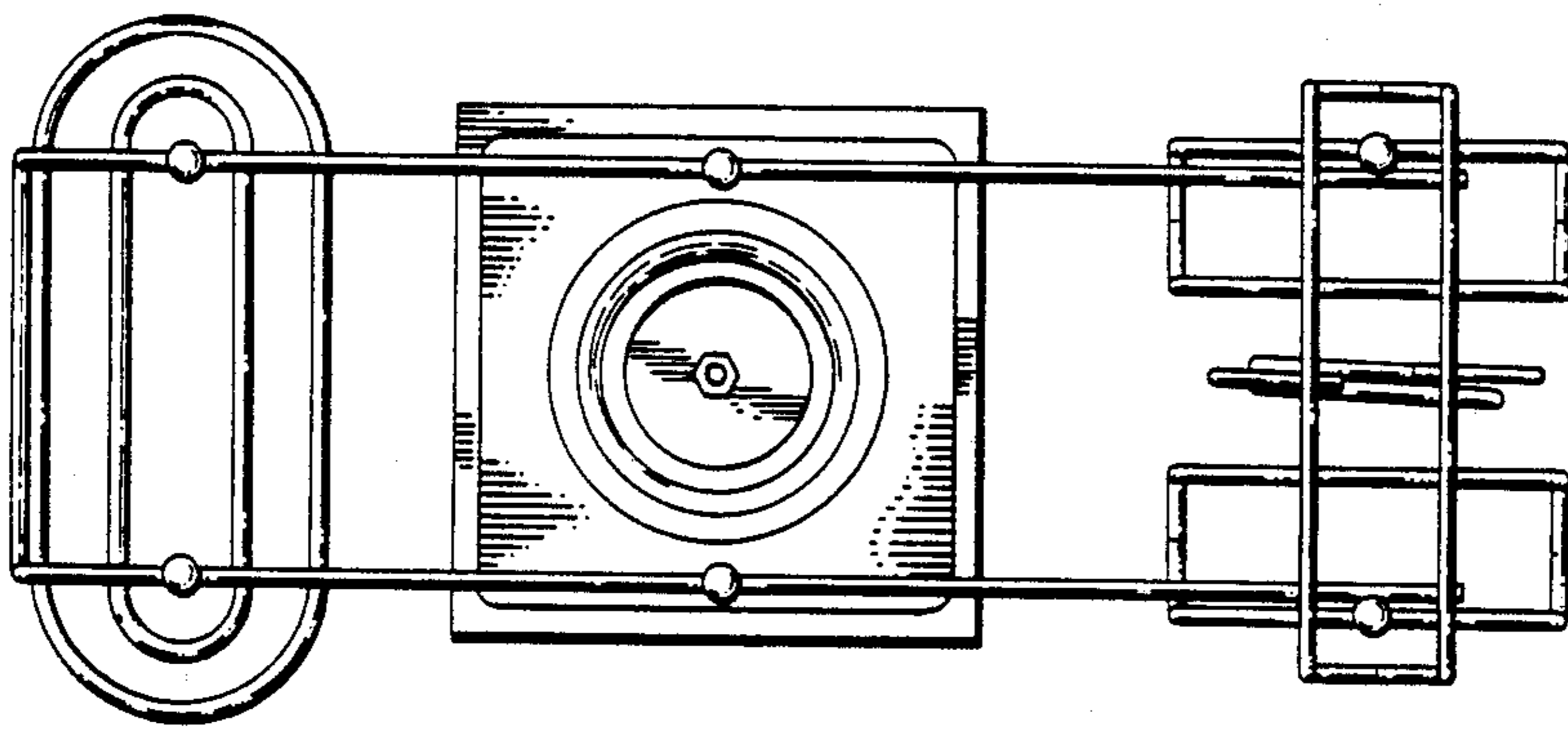

FIG. 4.

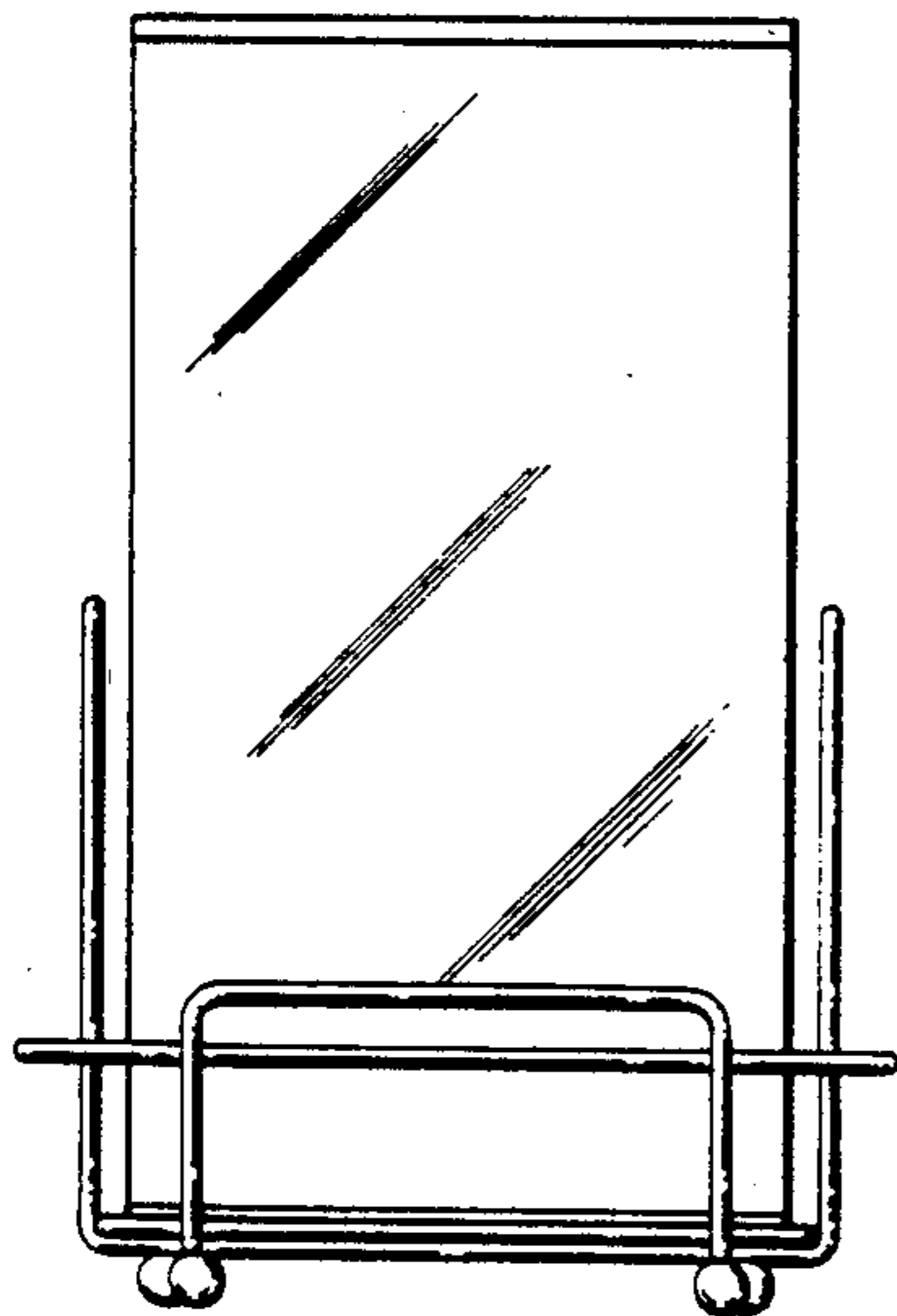

FIG. 5.

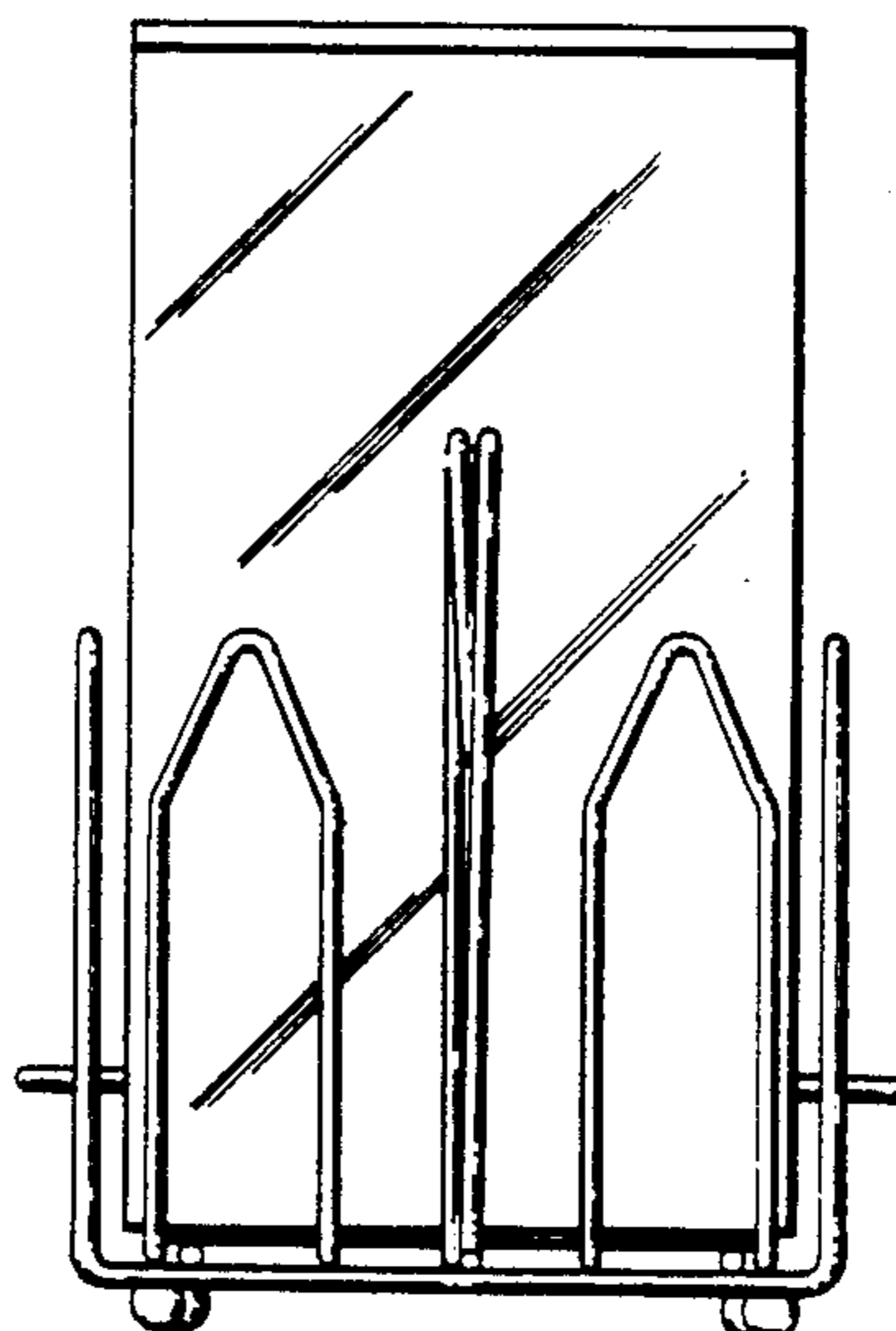

FIG. 6.