

[54] MOTORCYCLE ENGINE

[75] Inventors: William G. Davidson, Elm Grove; Louis N. Netz, Grafton, both of Wis.

[73] Assignee: Harley-Davidson, Inc., Milwaukee, Wis.

[**] Term: 14 Years

[21] Appl. No.: 770,608

[22] Filed: Aug. 29, 1985

[52] U.S. Cl. D15/3

[58] Field of Search D15/1, 3, 5; D21/125; D12/110, 114; 123/22, 41.34, 52 R, 56 R, 56 A, 56 B, 56 BA, 56 BC, 58 R, 311, 195 AC

[56] References Cited

U.S. PATENT DOCUMENTS

- D. 277,485 2/1985 Iwakura et al. D15/3
- D. 277,756 2/1985 Davidson D15/1
- D. 280,200 8/1985 Iwakura et al. D15/1

Primary Examiner—Wallace R. Burke
Assistant Examiner—Brian N. Vinson
Attorney, Agent, or Firm—John C. Cooper, III; Fred Wiviott; C. Thomas Sylke

[57] CLAIM

The ornamental design for a motorcycle engine, as shown.

DESCRIPTION

FIG. 1 is a right side elevational view of a motorcycle engine showing our new design;
FIG. 2 is a left side elevational view thereof;
FIG. 3 is a rear elevational view thereof;
FIG. 4 is a front elevational view thereof; and
FIG. 5 is a top plan view thereof.

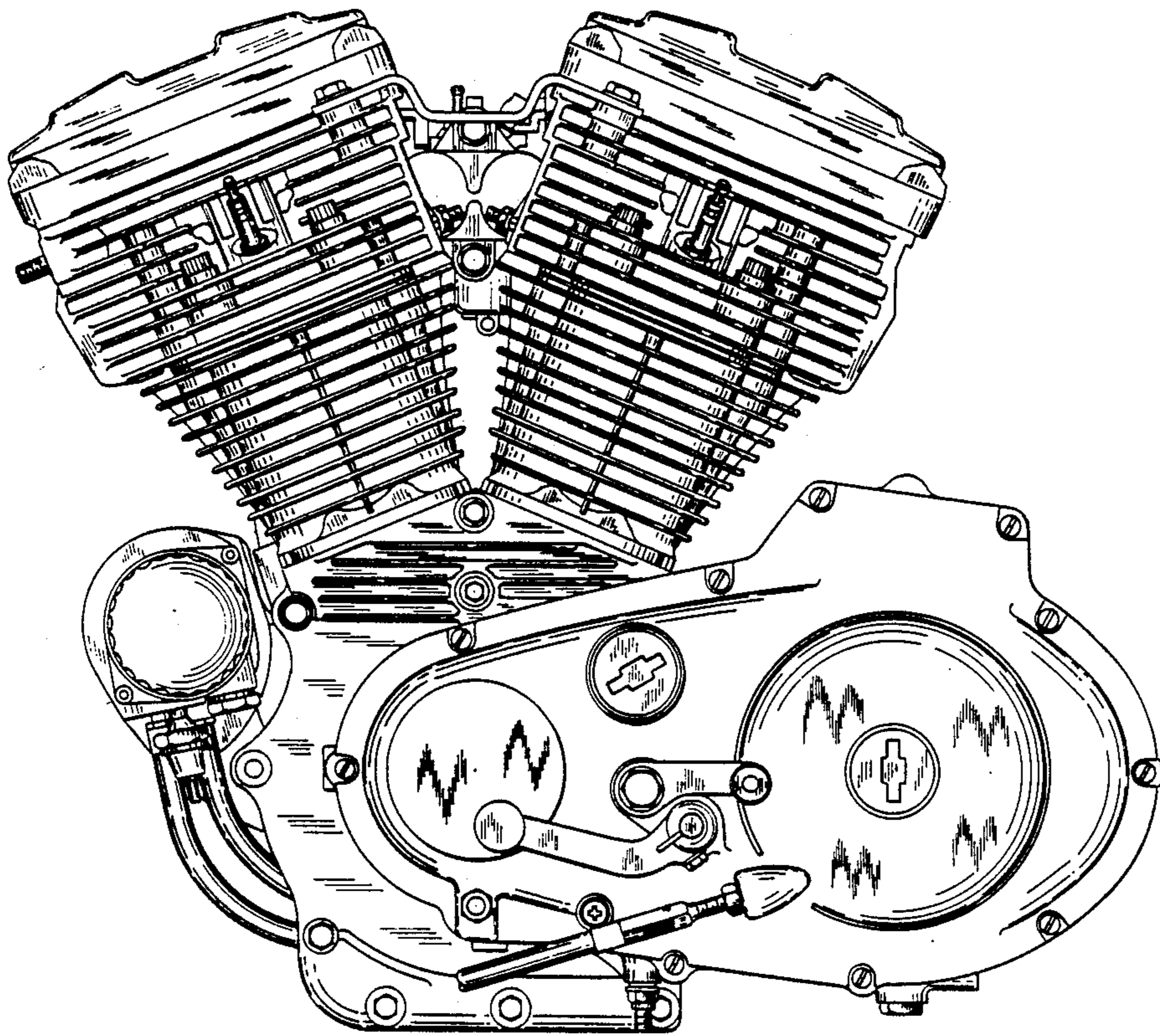

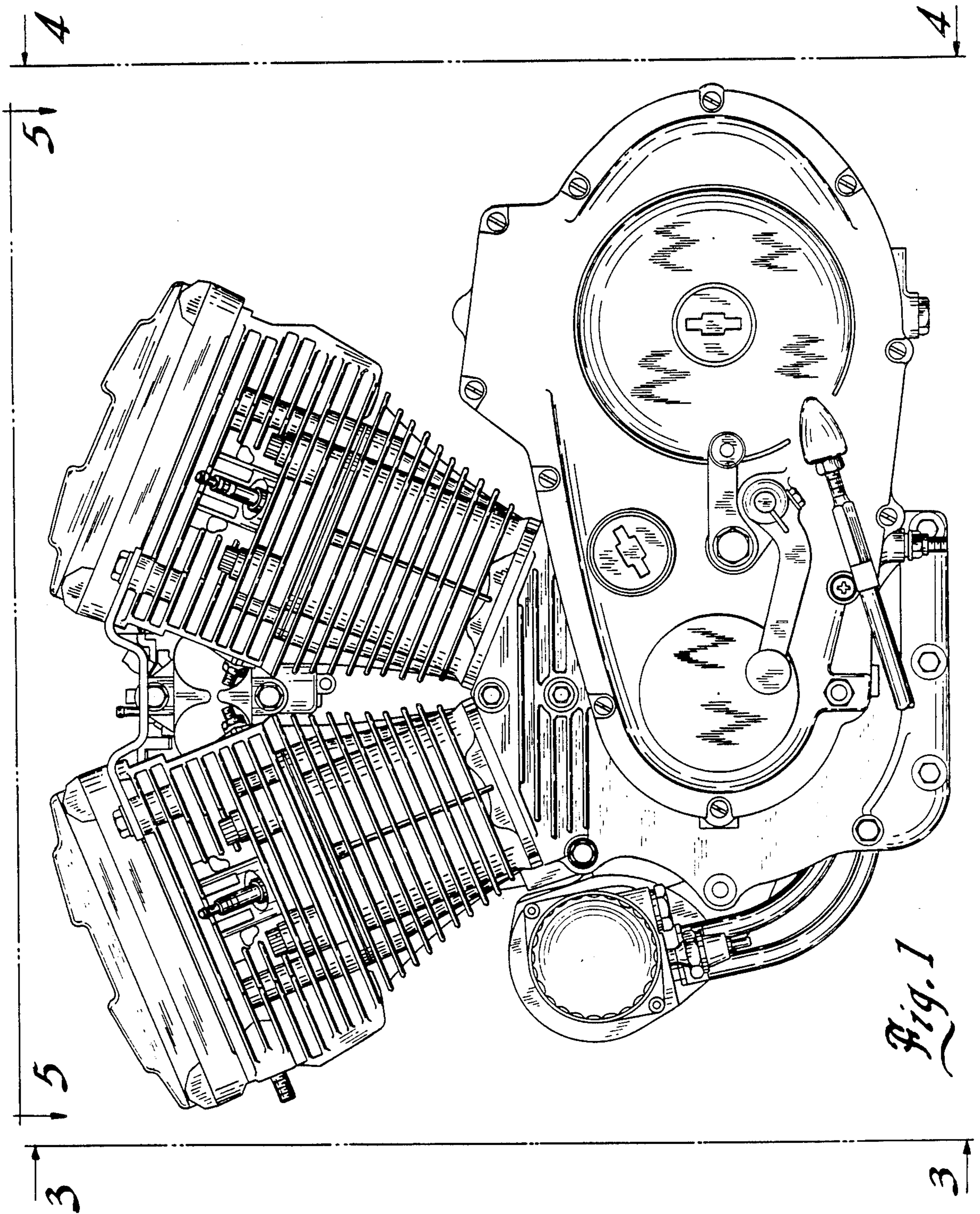

Fig. 1

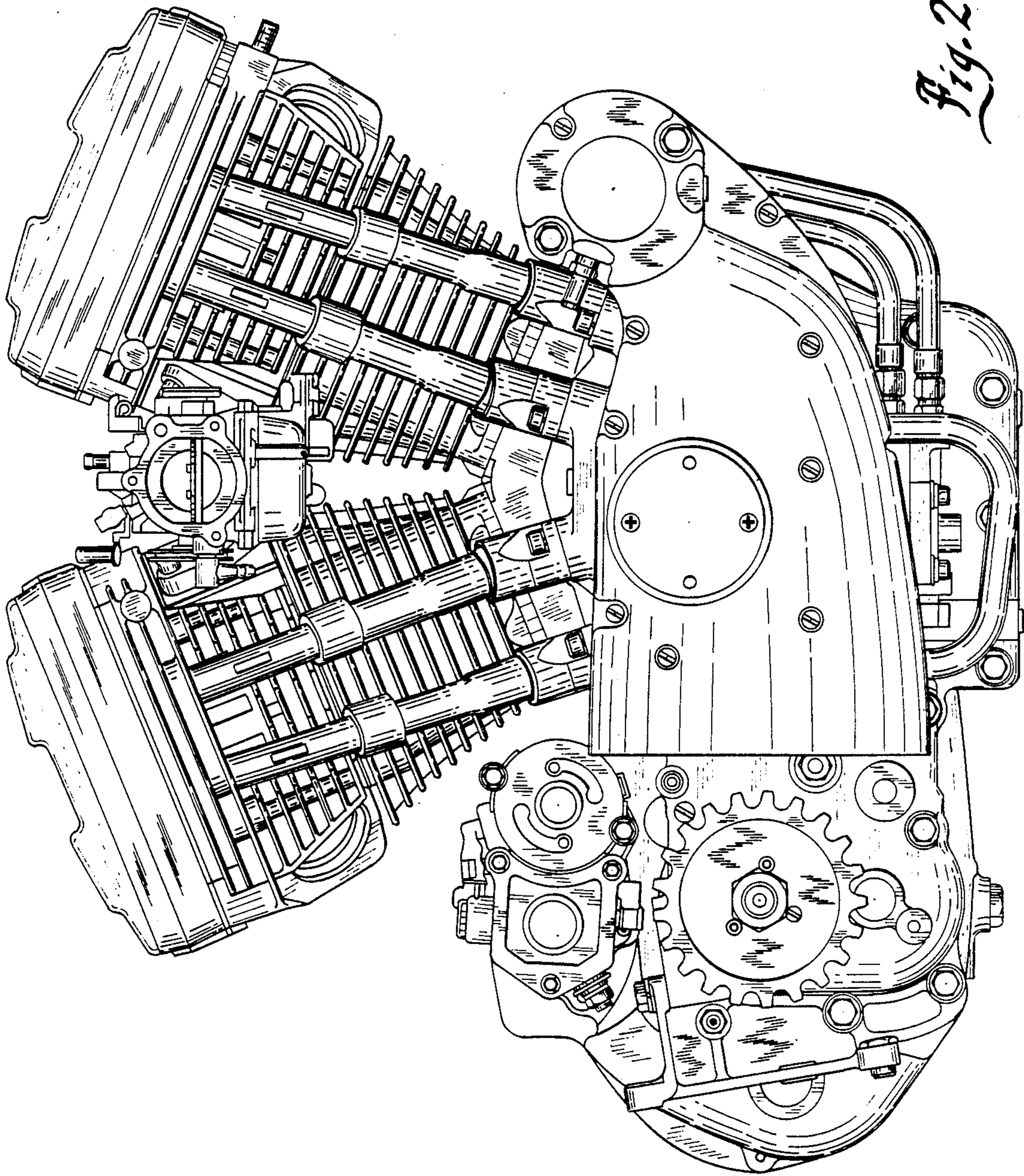

Fig. 2

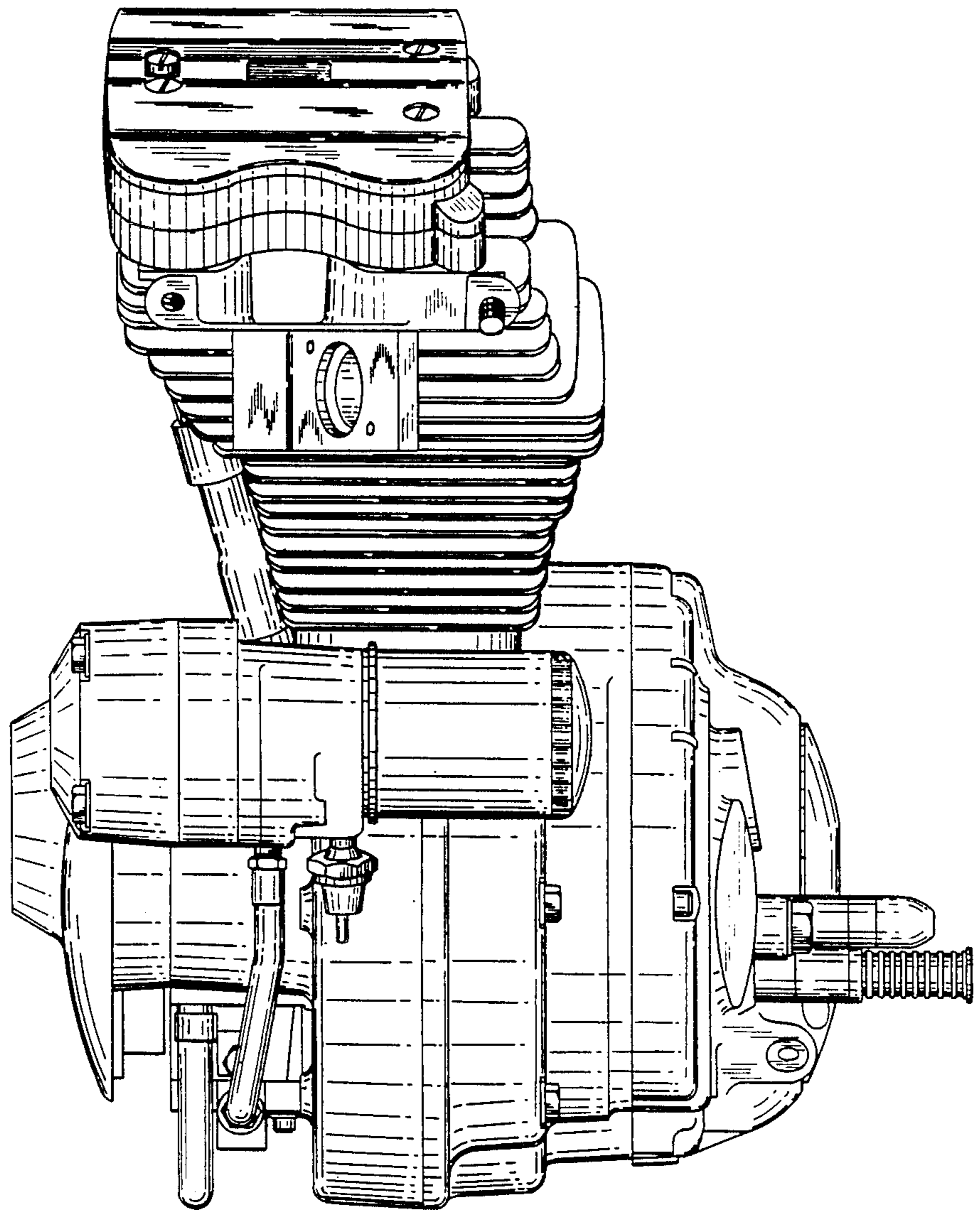

Fig. 3

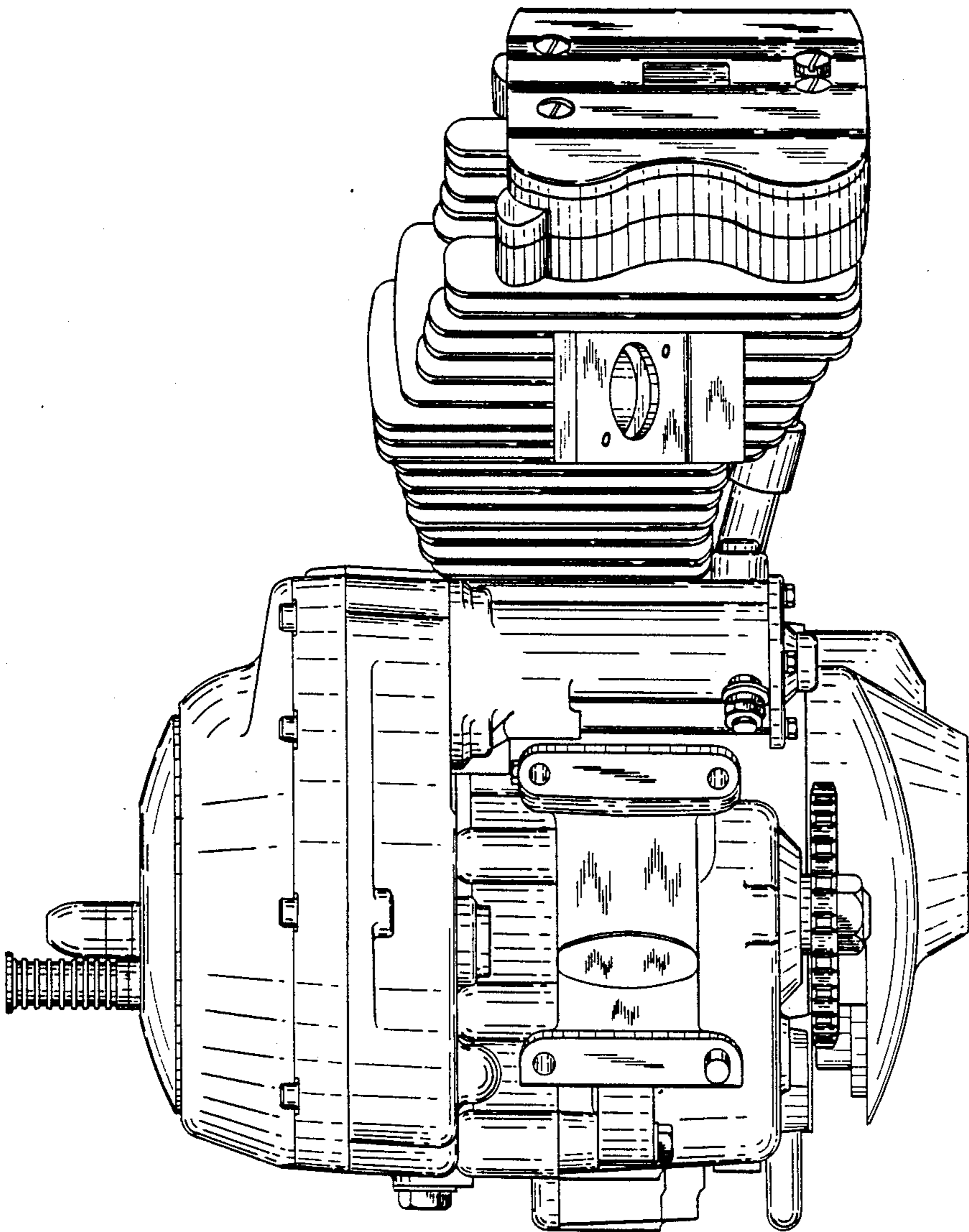

Fig. 4

