

[54] CHILDREN'S RIDE-ON SIMULATED FIRE TRUCK

1,890,658 12/1932 Swartz D21/78

[75] Inventors: Michael J. Clarke, Plantsville; Paul S. Santarsiero, Avon; John P. Kearney, West Suffield, all of Conn.

[73] Assignee: Coleco Industries, Inc., West Hartford, Conn.

[**] Term: 14 Years

[21] Appl. No.: 700,400

[22] Filed: Feb. 11, 1985

[52] U.S. Cl. D12/108

[58] Field of Search D12/108, 112; D21/78; 280/282; 296/177

[56] References Cited

U.S. PATENT DOCUMENTS

D. 271,315 11/1983 Nottingham et al. D21/78

OTHER PUBLICATIONS

1985/1985 Best Catalog, p. 413, Coleco Cabbage Patch Kids 16" Power Cycle, lower right side of page.

Primary Examiner—James M. Gandy

[57] CLAIM

The ornamental design for a children's ride-on simulated fire truck, as shown.

DESCRIPTION

FIG. 1 is a perspective view of a children's ride-on simulated fire truck showing our new design; FIG. 2 is a top plan view thereof; FIG. 3 is a bottom plan view thereof; FIG. 4 is a side elevational view thereof; FIG. 5 is an elevational view of the side opposite that shown in FIG. 4; FIG. 6 is a rear elevational view thereof; and FIG. 7 is a front elevational view thereof.

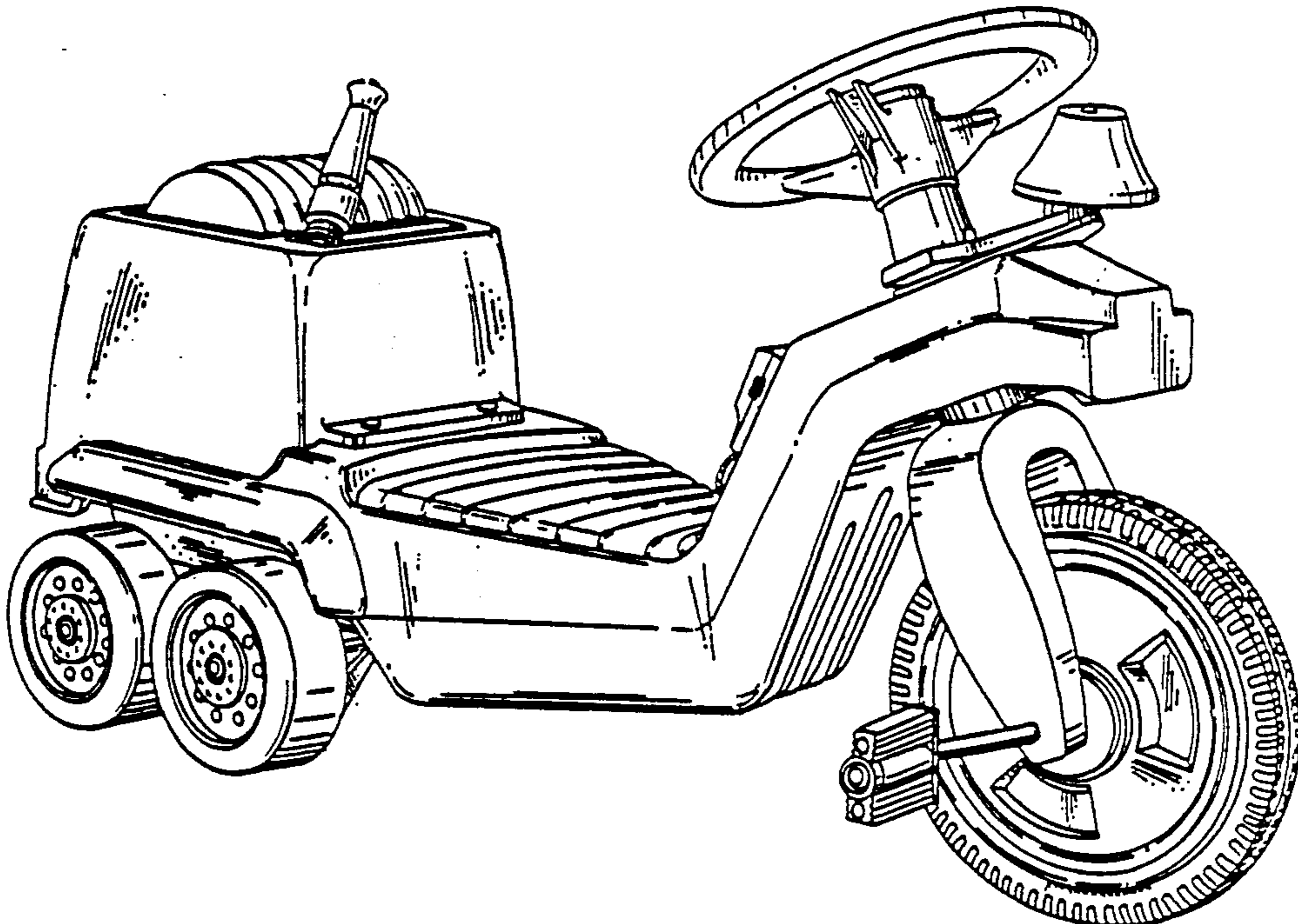

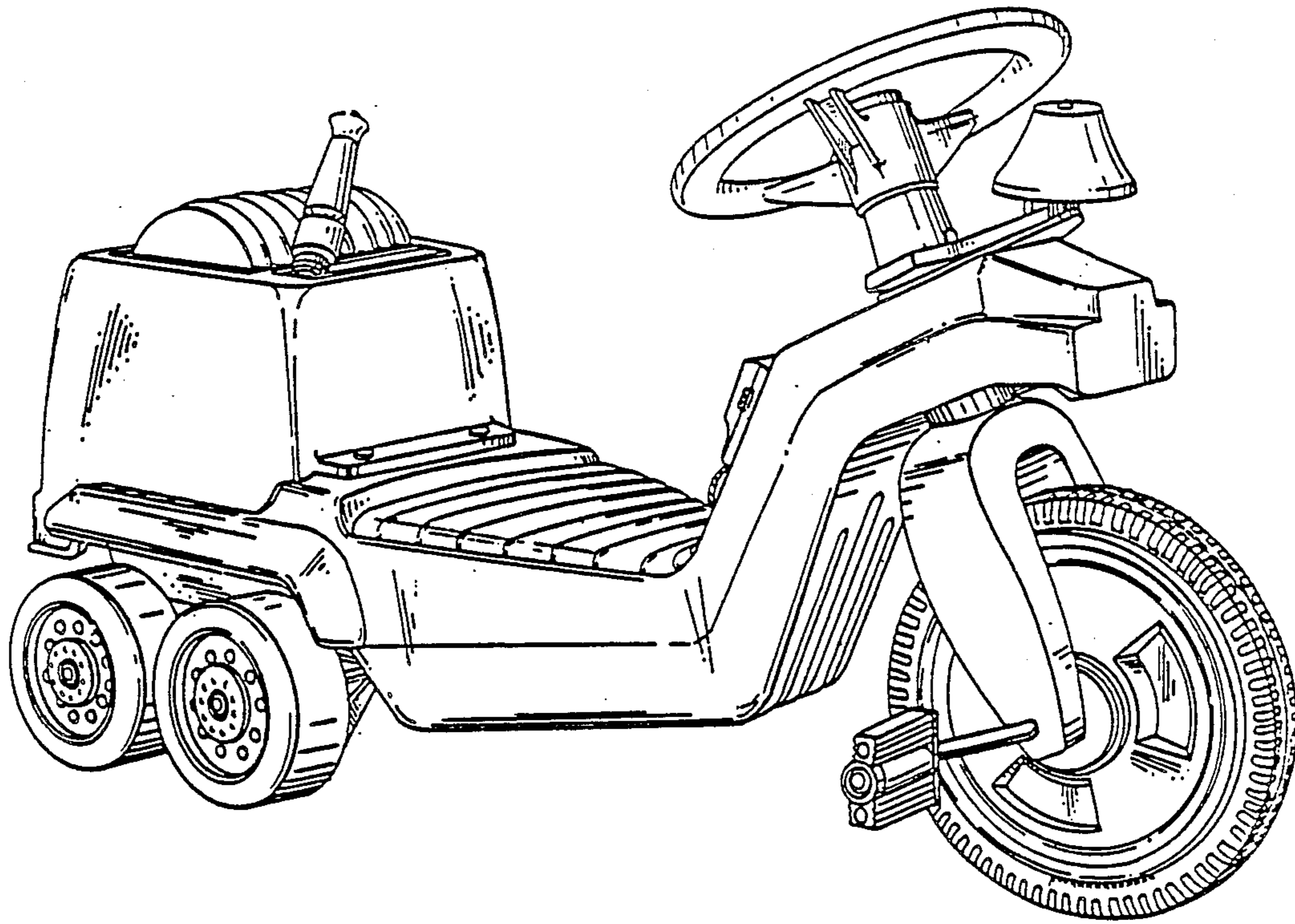

FIG. 1

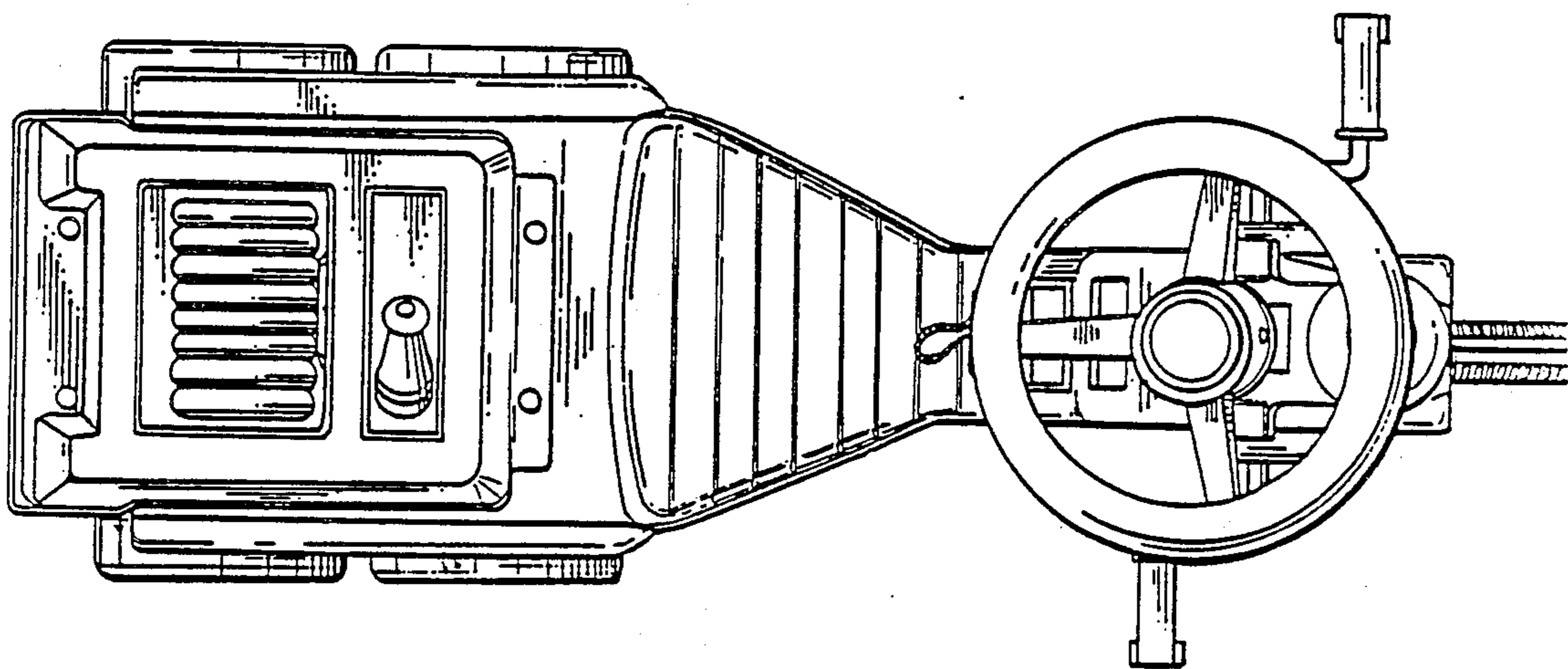

FIG. 2

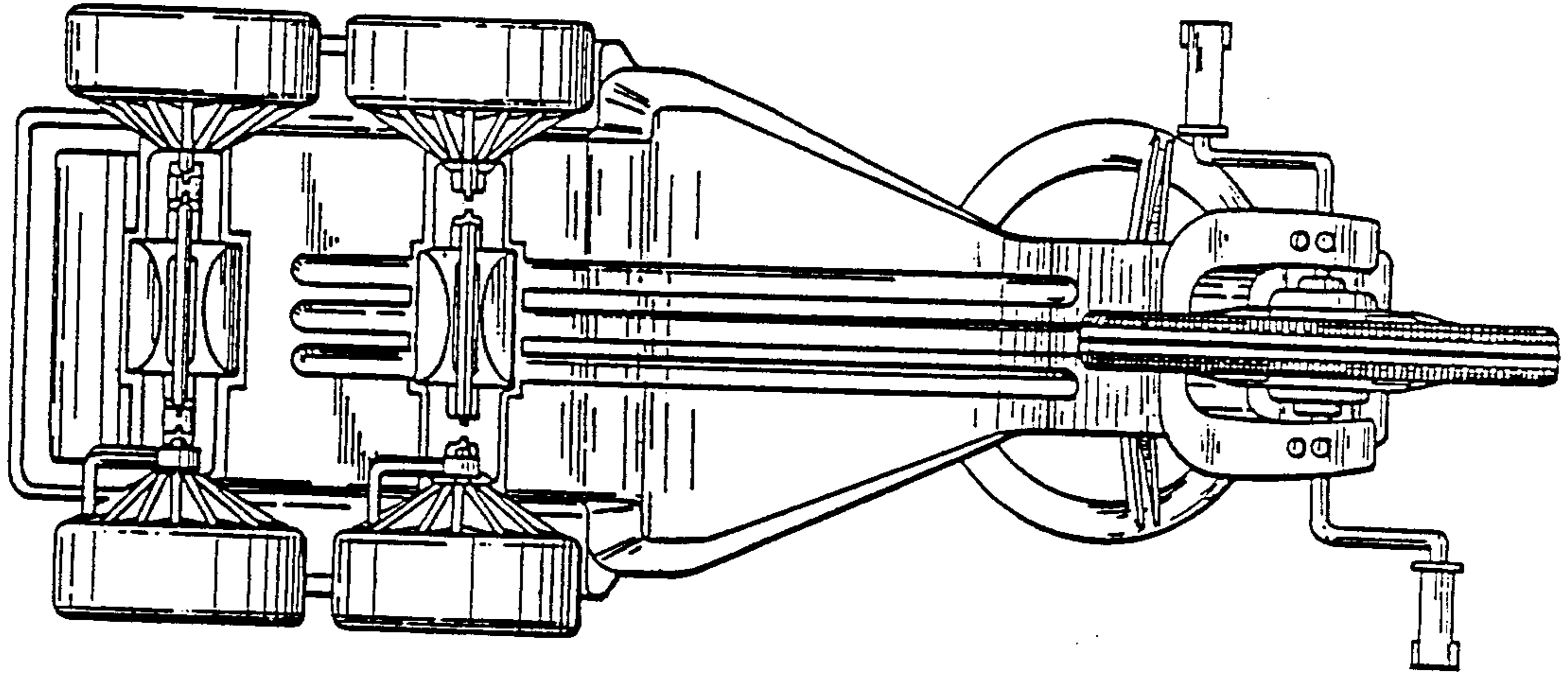

FIG. 3

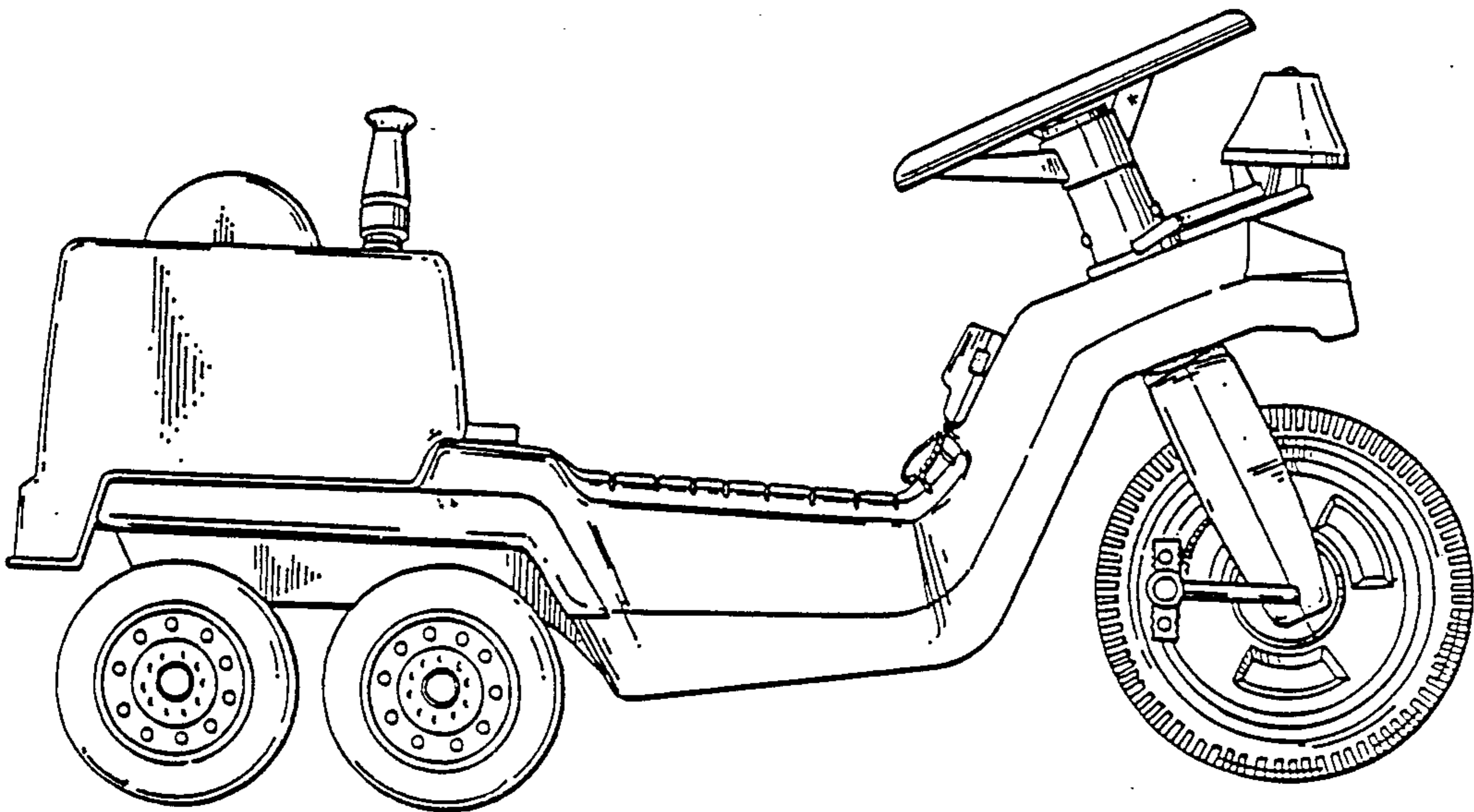

FIG. 4

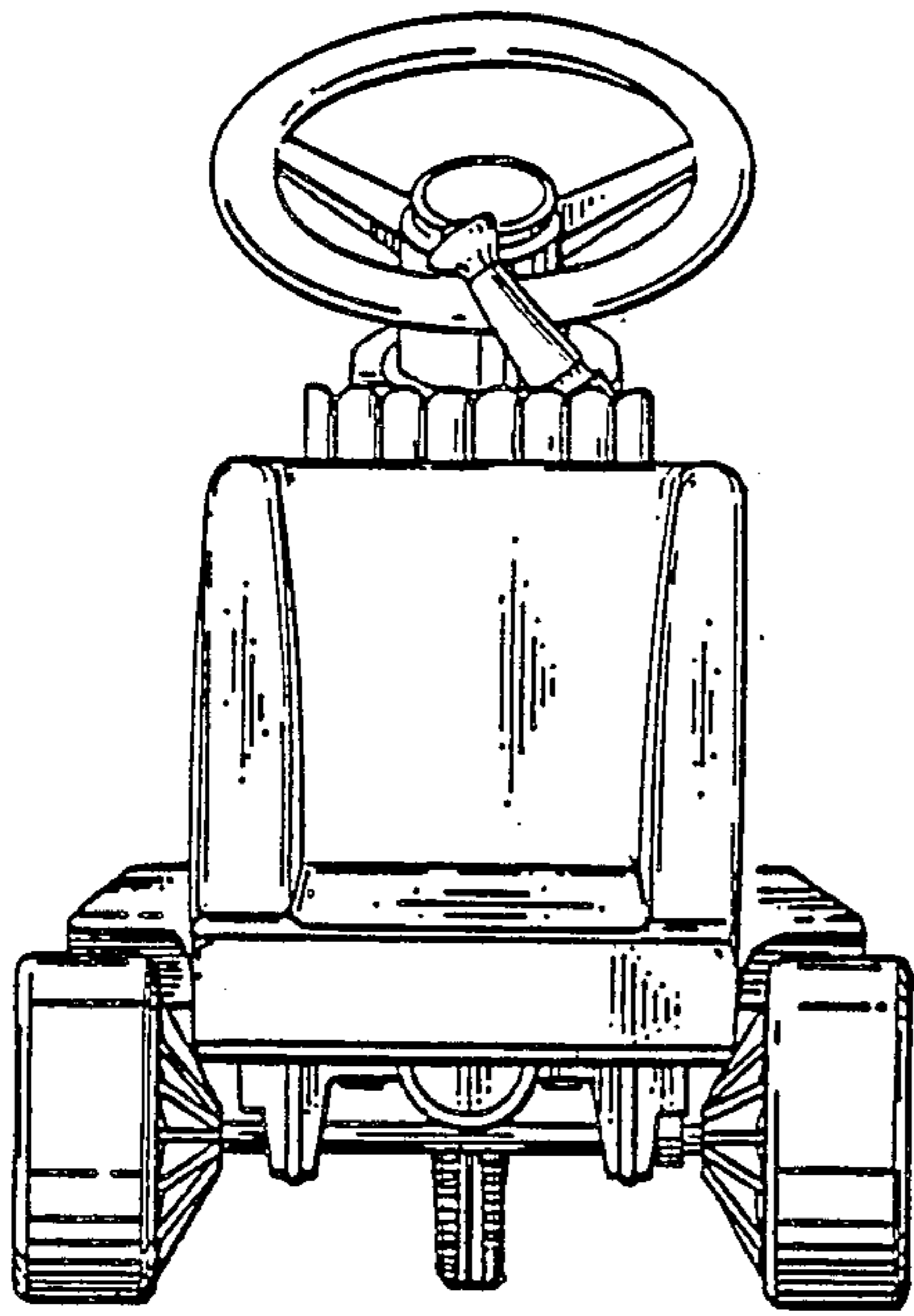

FIG. 6

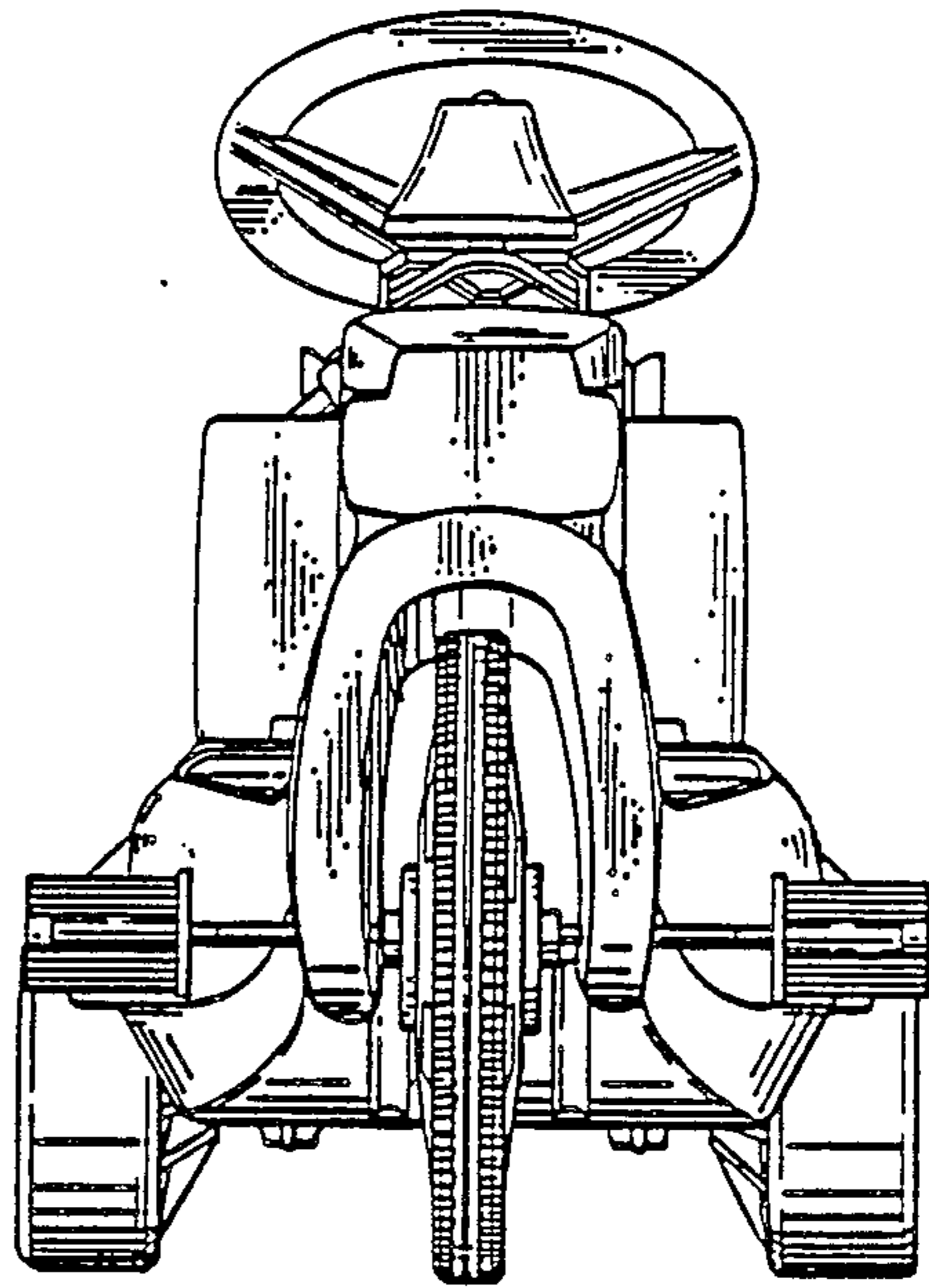

FIG. 7

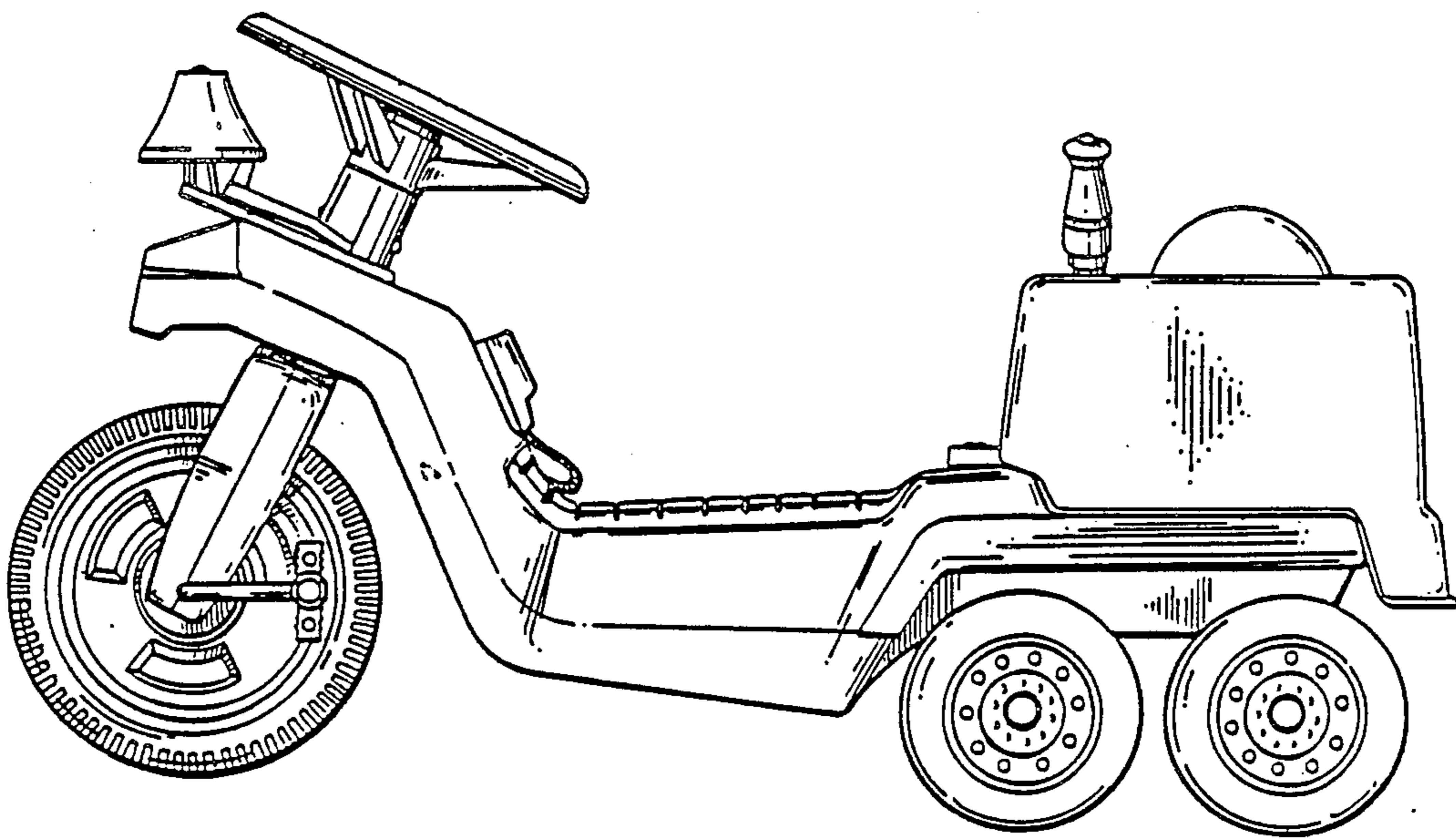

FIG. 5