

[54] FUEL GAUGE FOR DUAL-FUEL AUTOMOBILES

[75] Inventors: Rubens Basaglia; Ezio Bollina, both of Bologna, Italy

[73] Assignee: B & B Engineering S.r.l., Bologna, Italy

[**] Term: 14 Years

[21] Appl. No.: 666,461

[22] Filed: Oct. 30, 1984

[30] Foreign Application Priority Data

May 11, 1984 [IT] Italy 4890/84[U]
[52] U.S. Cl. D10/101
[58] Field of Search D10/85, 101, 102, 103, D10/69, 70; 33/348; 374/431; 73/291, 714

[56] References Cited

U.S. PATENT DOCUMENTS

D. 99,975	6/1936	Heuer	D10/102
D. 100,193	6/1936	Baker	D10/102
D. 125,445	2/1941	Hull	D10/68
D. 148,962	3/1948	Sherrill	D10/68
D. 207,845	6/1967	Gerhardt	D10/101
D. 270,816	10/1983	Hays	D10/70
842,092	1/1907	Glover	33/348 X
4,562,732	1/1986	Kitagawa	73/291

Primary Examiner—Nelson C. Holtje
Attorney, Agent, or Firm—Laff, Whitesel, Conte & Saret

[57] CLAIM

The ornamental design for a fuel gauge for dual-fuel automobiles, as shown and described.

DESCRIPTION

FIG. 1 is front elevational of a fuel gauge for dual-fuel automobiles showing my new design;
FIG. 2 is a top plan view thereof;
FIG. 3 is a left side elevational view thereof, the right side being a mirror image thereto;
FIG. 4 is a rear elevational view thereof;
FIG. 5 is a left front perspective view thereof.

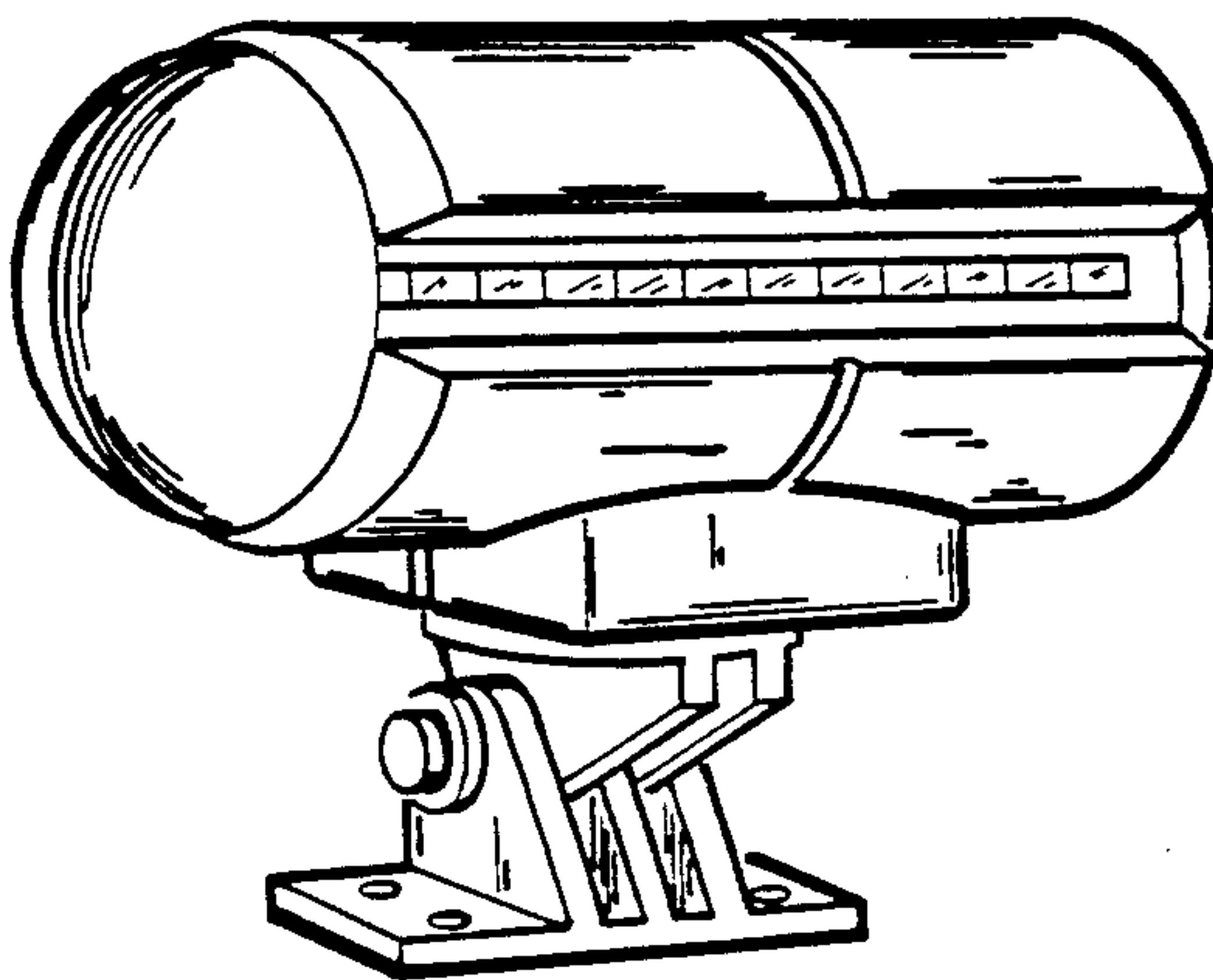

FIG 1

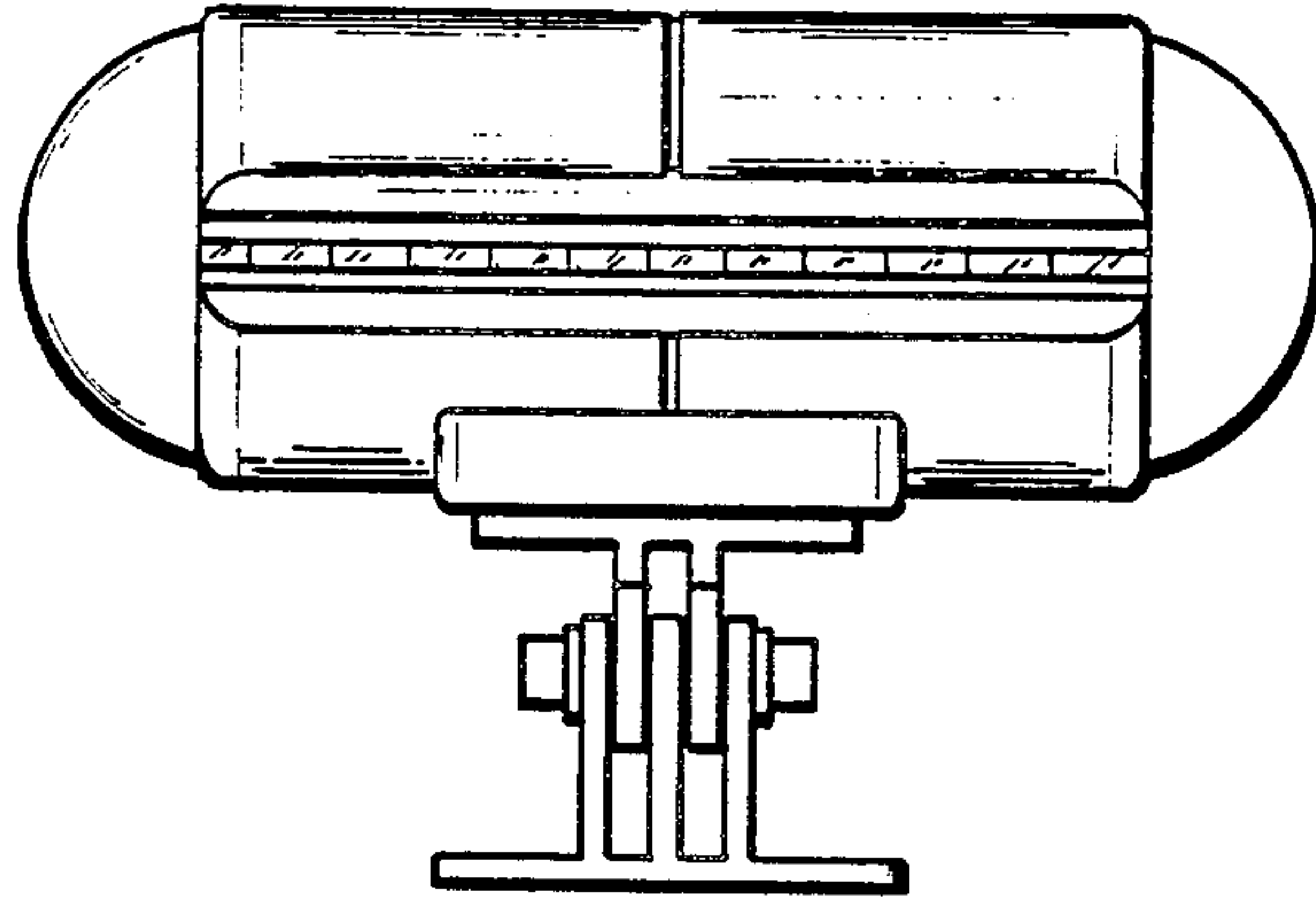

FIG 2

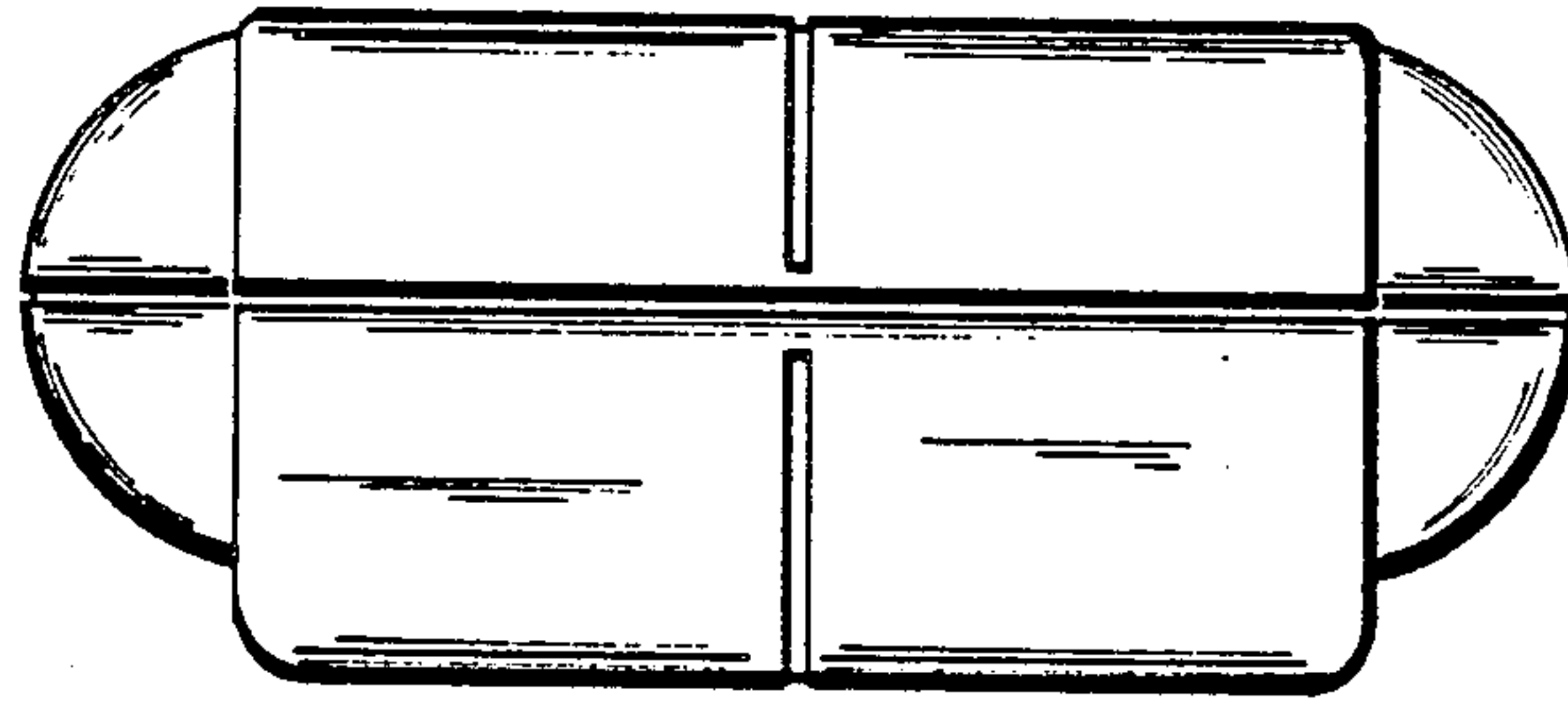

FIG4

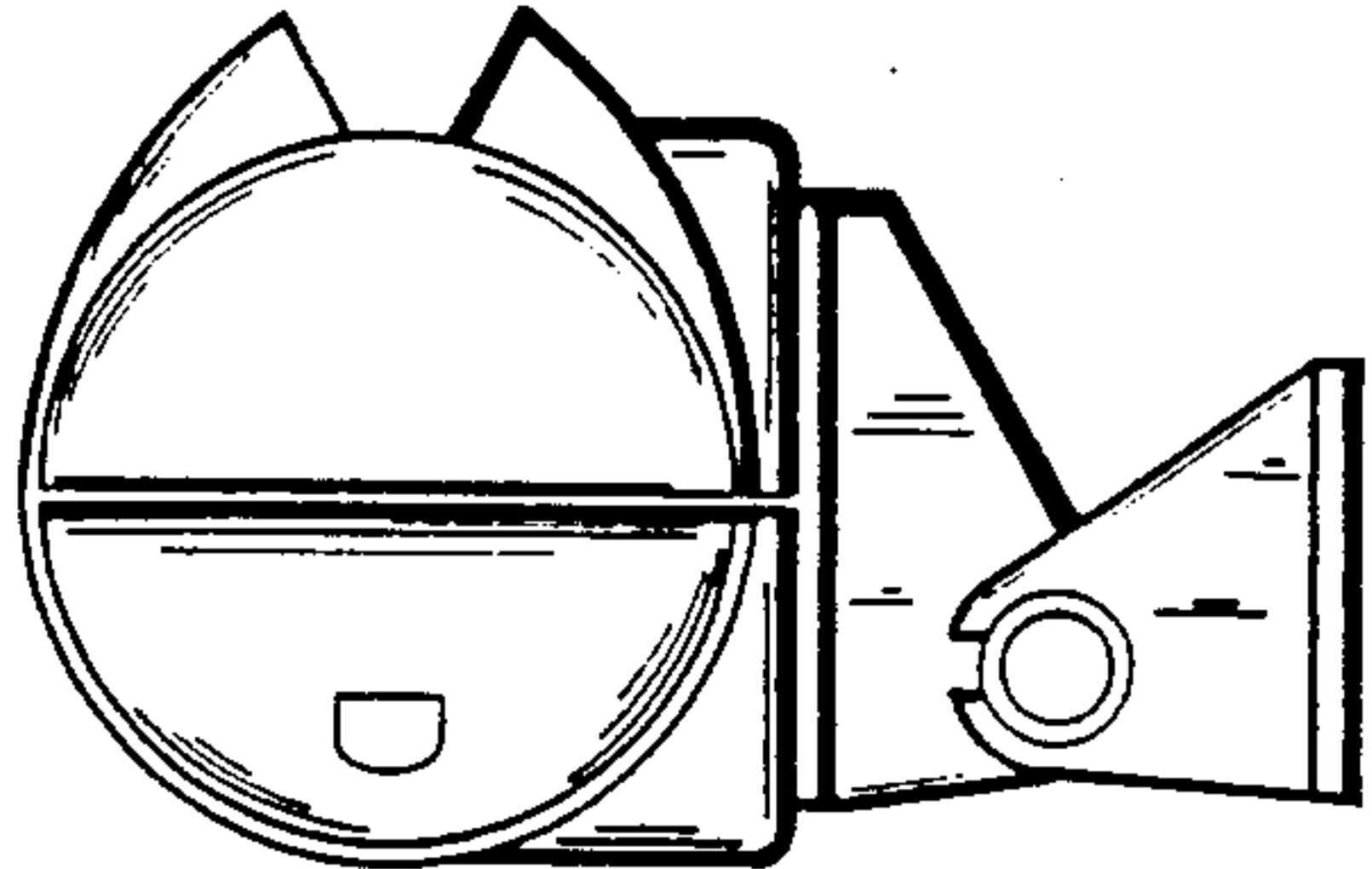
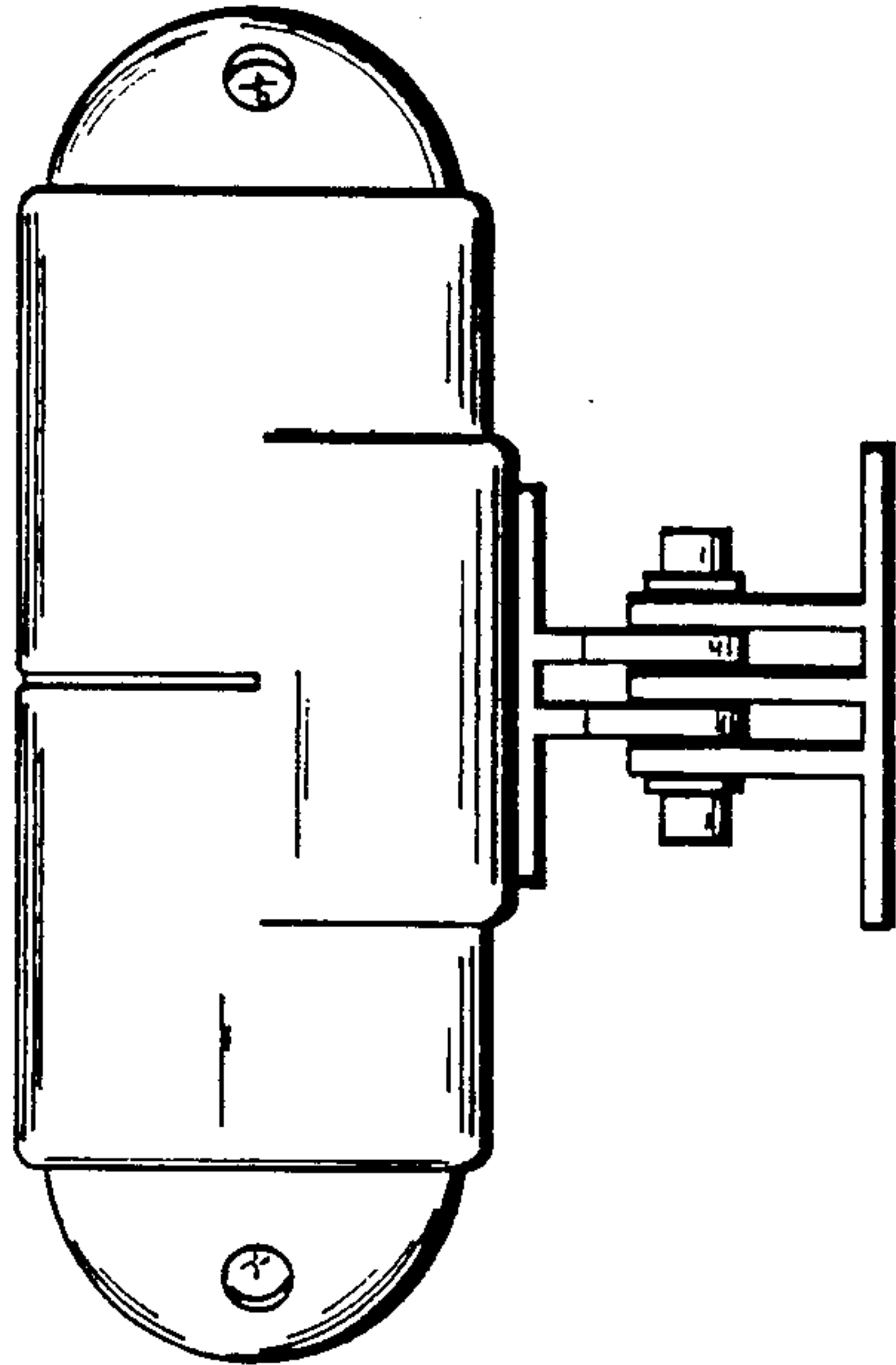

FIG3

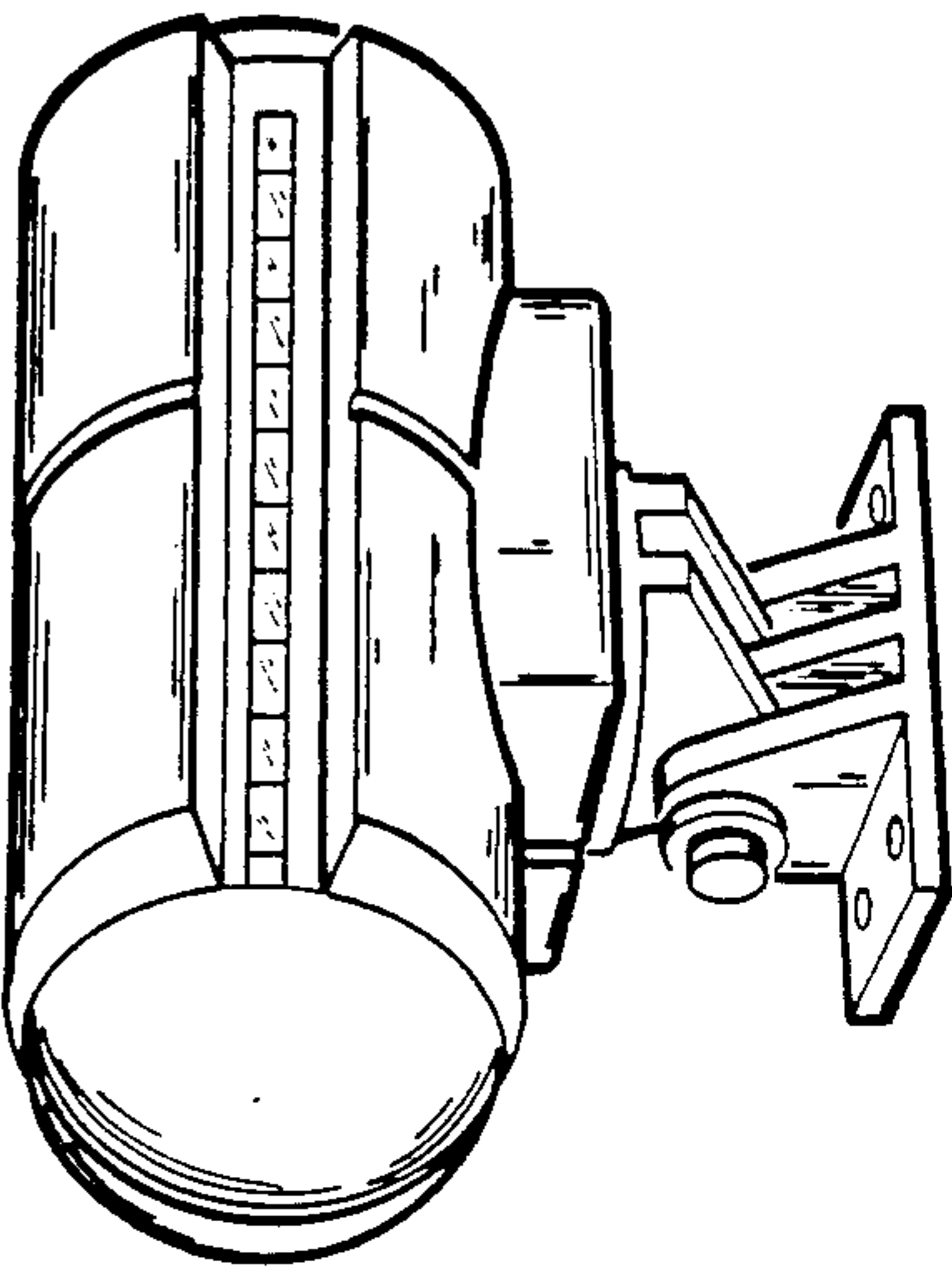

FIG5