

[54] ENERGY SAVING LANTERN

[76] Inventor: Dorothy Jennings, 10443 Decker,
Overland, Mo. 63114

[**] Term: 14 Years

[21] Appl. No.: 700,463

[22] Filed: Feb. 11, 1985

[52] U.S. Cl. D26/50; D26/46

[58] Field of Search D26/37-50;
362/157, 158, 183-191, 194-205

[56] References Cited

U.S. PATENT DOCUMENTS

D. 199,038	9/1964	Nicholl et al.	D26/48
D. 210,408	3/1968	Tesar	D26/48
D. 214,254	5/1969	Cheslock	D26/48
1,301,253	4/1919	Grether	362/197
4,285,030	8/1981	Menelly	362/200

Primary Examiner—Susan J. Lucas
Attorney, Agent, or Firm—Gilden & Israel

[57] CLAIM

The ornamental design for an energy saving lantern, as shown and described.

DESCRIPTION

FIG. 1 is a top, side perspective view of an energy saving lantern showing my new design;

FIG. 2 is a left end elevational view thereof, on a reduced scale;

FIG. 3 is a right end elevational view thereof, on a reduced scale;

FIG. 4 is a bottom plan view thereof, on a reduced scale;

FIG. 5 is an elevational view of the side opposite that shown in FIG. 1 on a reduced scale;

FIG. 6 is an elevational view of the side shown in FIG. 1.

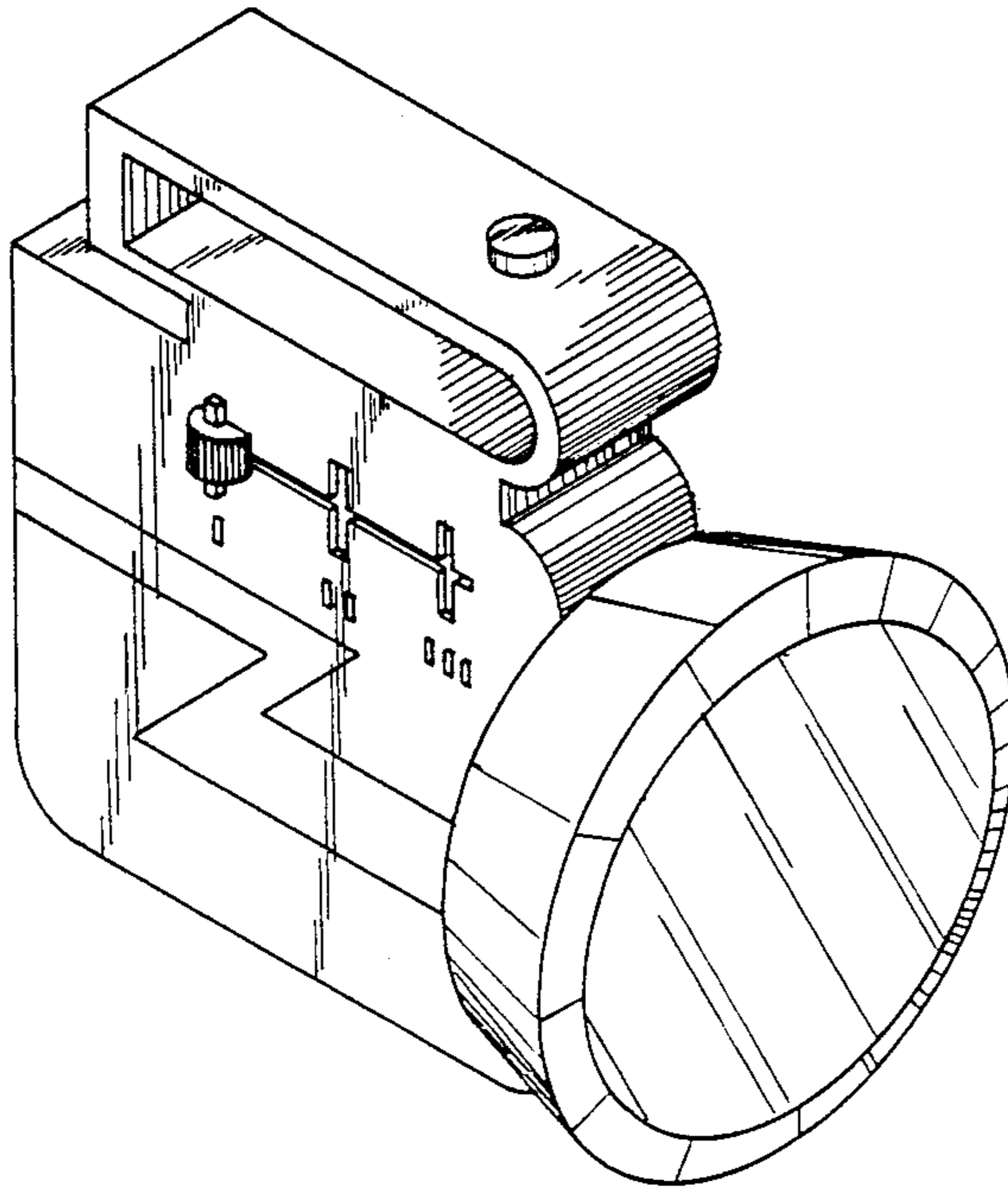

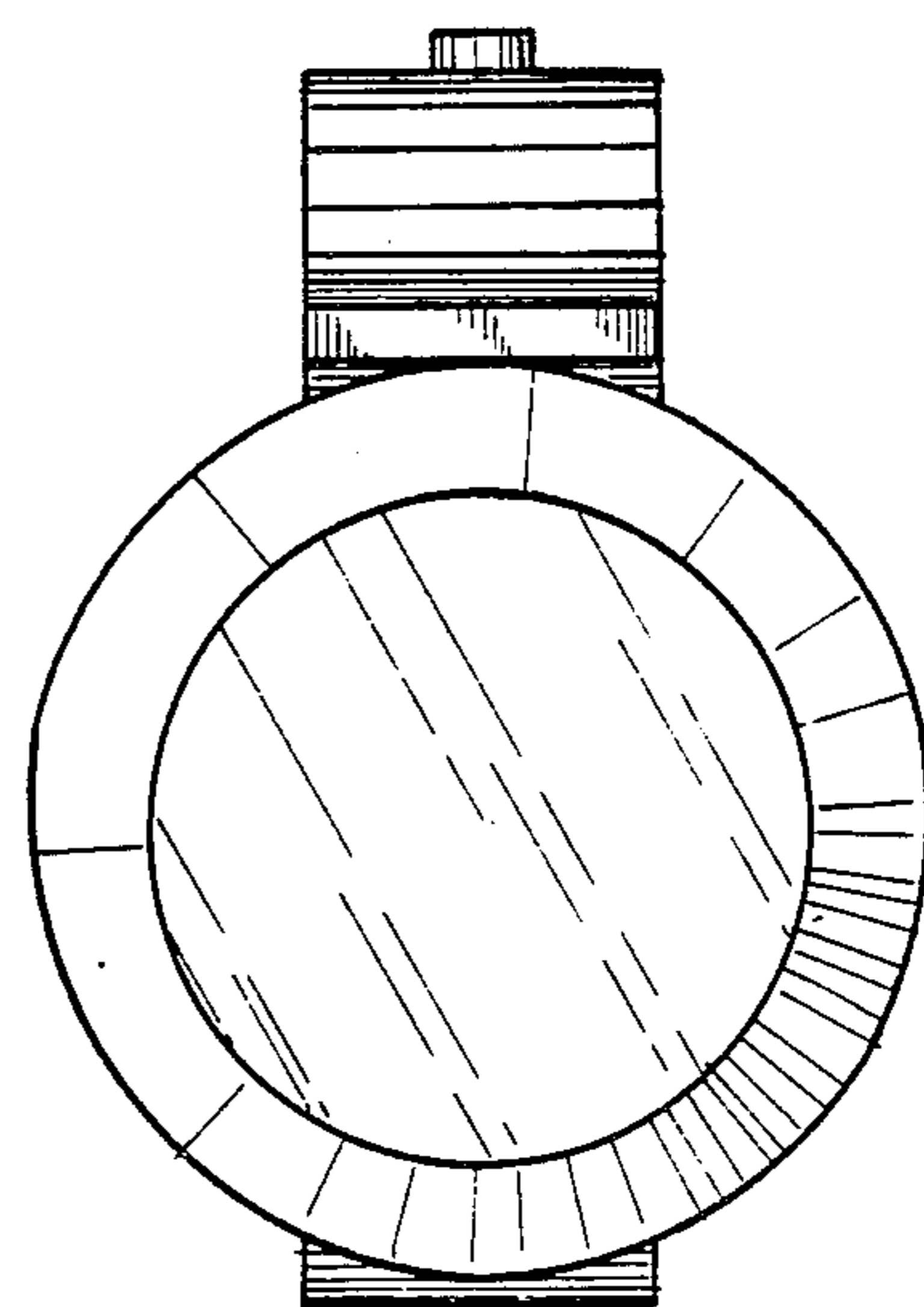
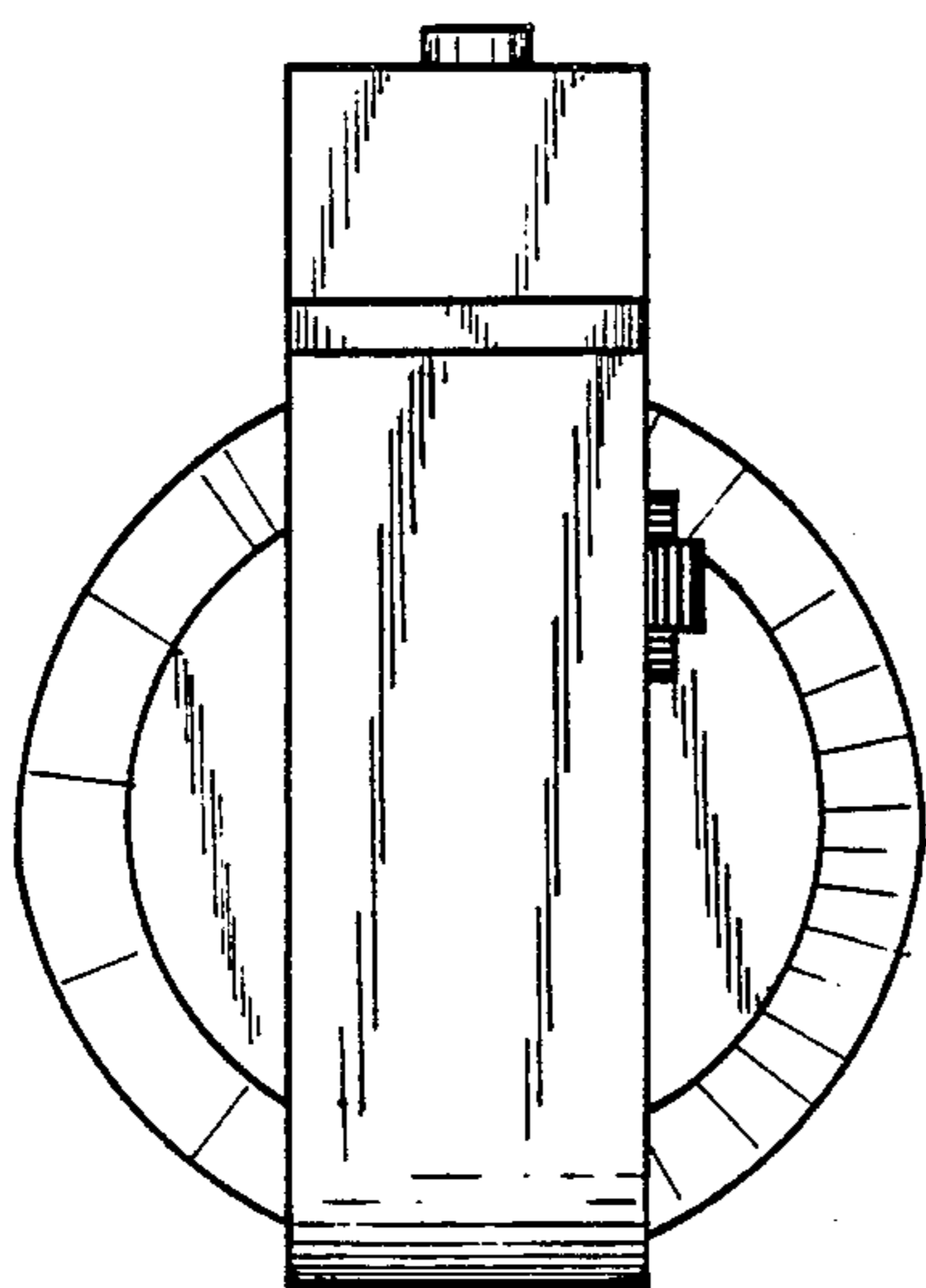
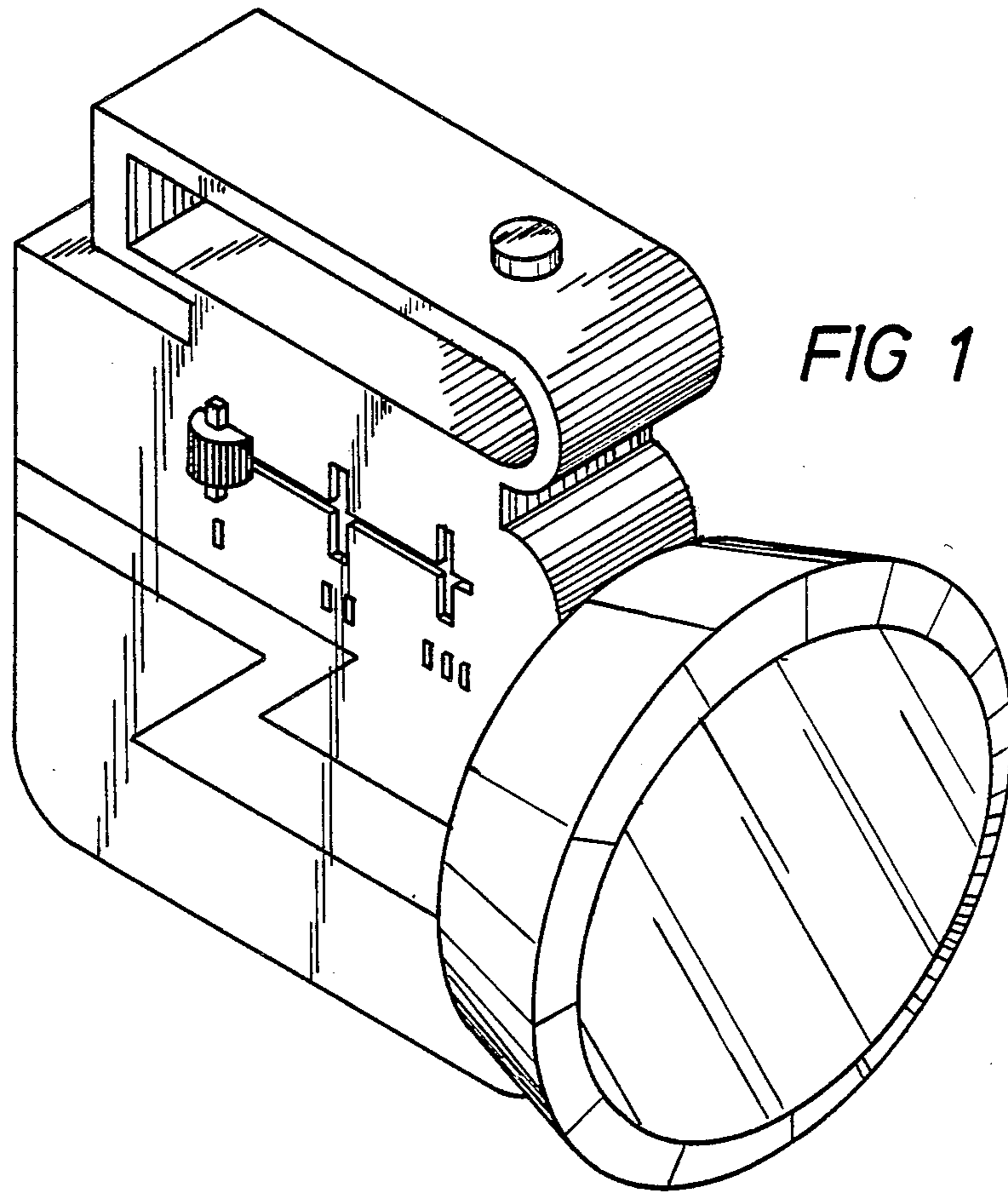

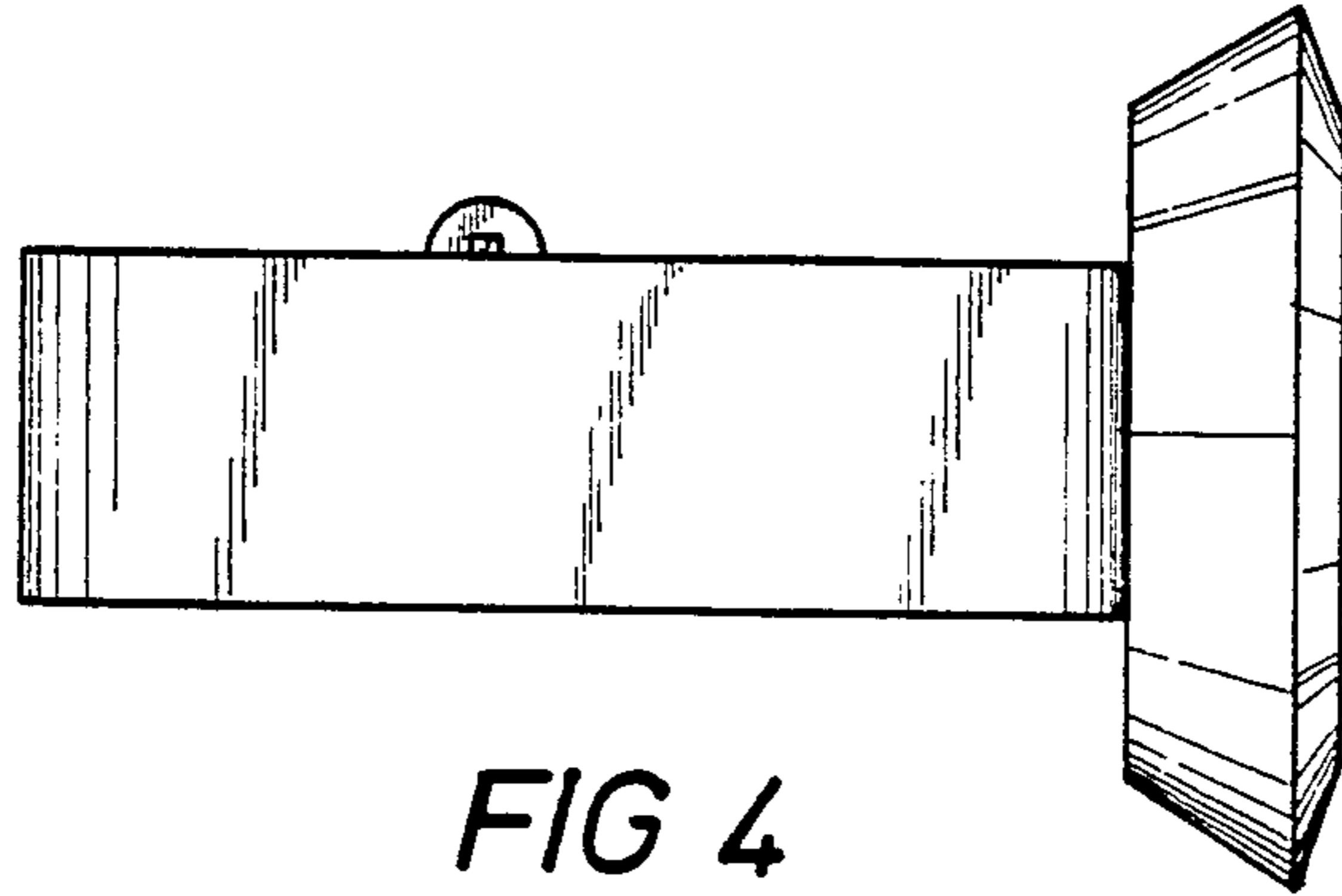

FIG 4

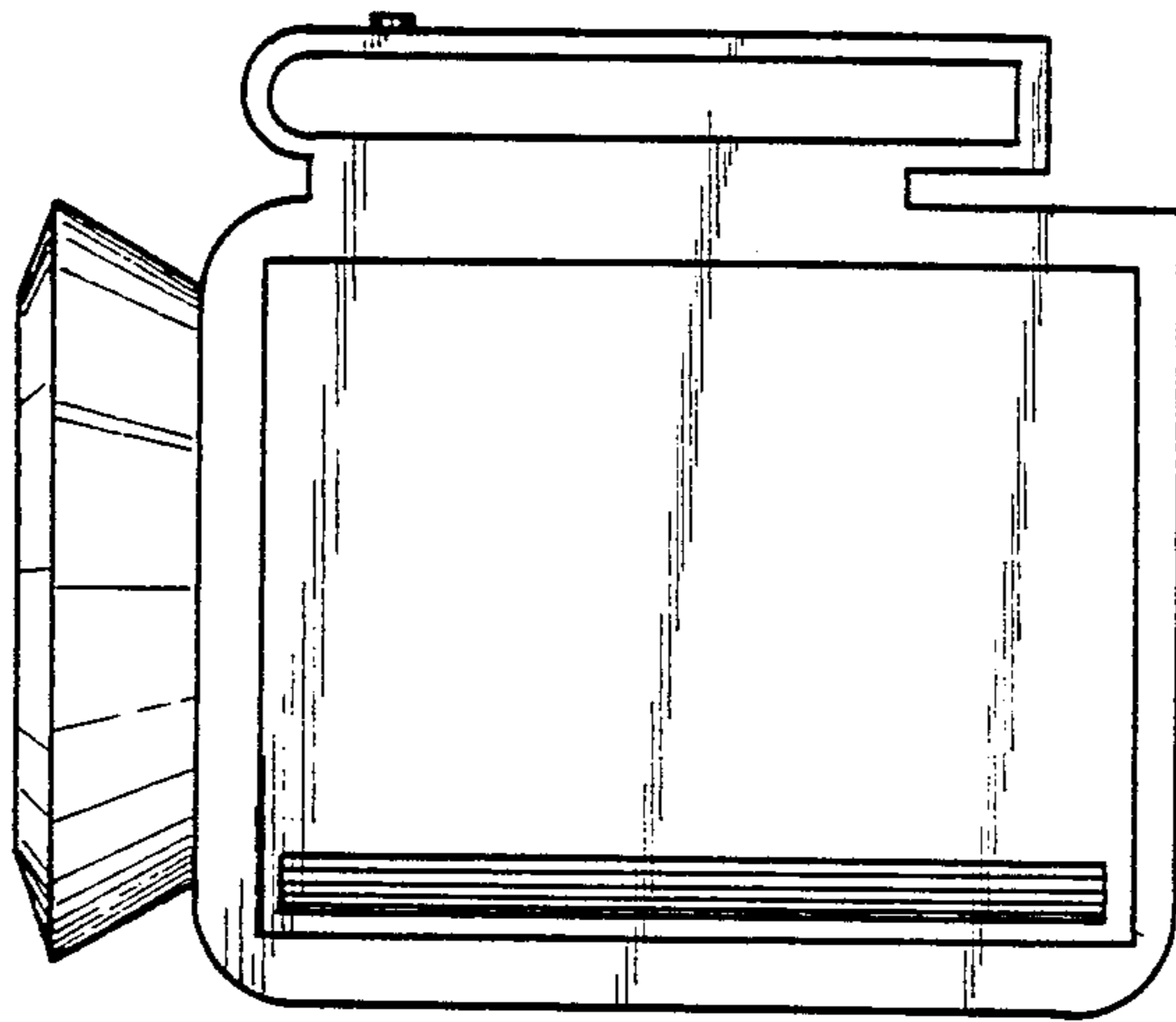

FIG 5

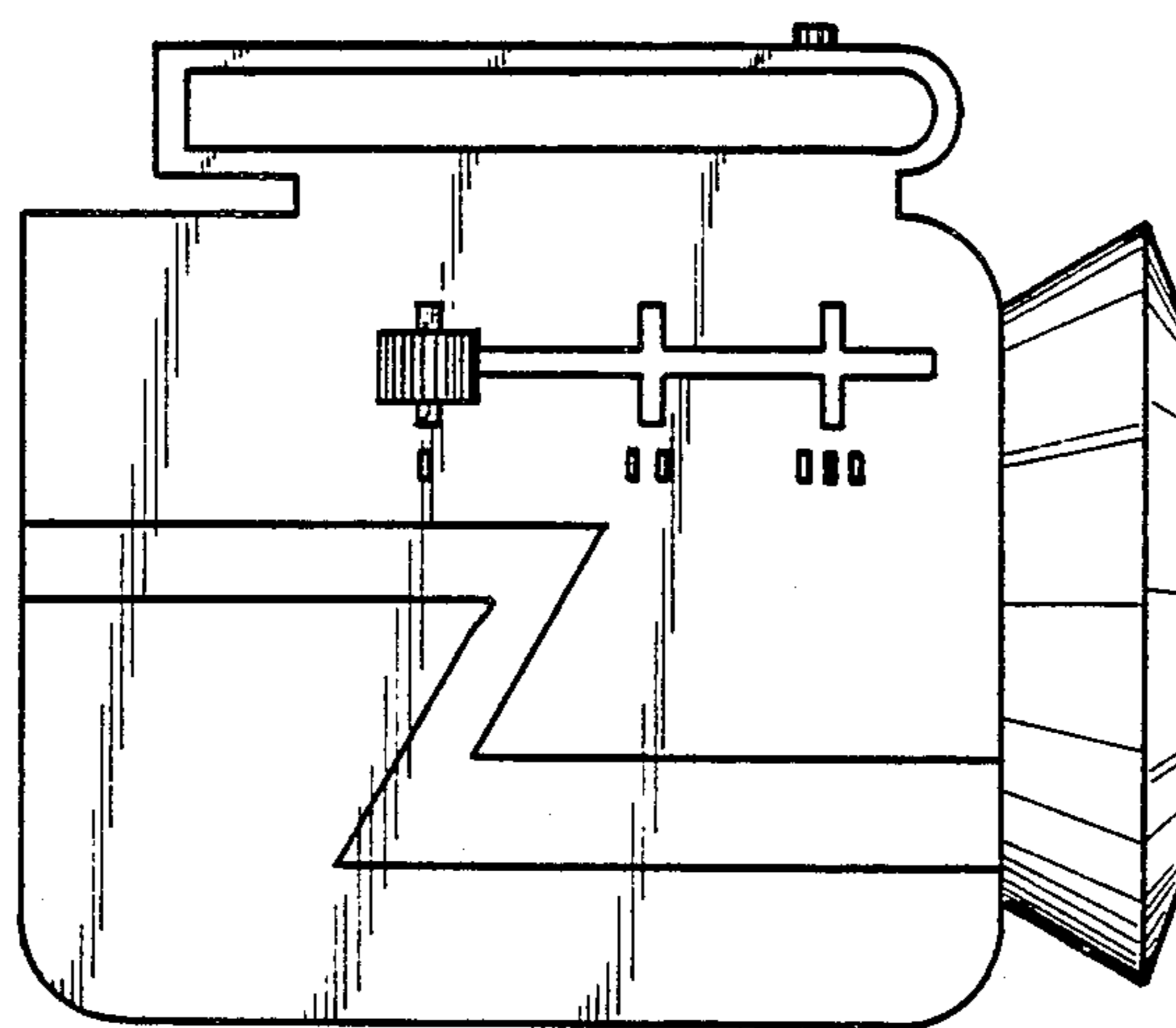

FIG 6