

[54] CHALK LINE ROLLER

[76] Inventor: Merriman E. Call, 223 Yorktown Rd., Tabb, Va. 23602

[\*\*] Term: 14 Years

[21] Appl. No.: 652,097

[22] Filed: Sep. 19, 1984

[52] U.S. Cl. .... D4/121; D4/122

[58] Field of Search ..... 15/230.11; 369/72-74; 29/110, 110.5; 401/197, 208, 218-220; 33/414; D4/121, 122

[56] References Cited

U.S. PATENT DOCUMENTS

892,962 7/1908 Lancaster et al. .... 401/208 X

1,792,441	2/1931	Palmer .....	401/208 X
2,165,812	7/1939	Pfleger .....	401/208
2,298,682	10/1942	Dahlstrom .....	15/230.11
2,935,757	5/1960	Phillips .....	15/230.11
3,357,037	12/1967	Kaplan .....	15/230.11
3,599,268	8/1971	Simpkins et al. ....	15/230.11

Primary Examiner—Catherine E. Kemper  
Attorney, Agent, or Firm—Gilden & Israel

[57] CLAIM

The ornamental design for a chalk line roller, as shown and described.

DESCRIPTION

FIG. 1 is an end elevational view of a chalk line roller, showing my new design;  
FIG. 2 is a perspective view thereof, shown on an enlarged scale.

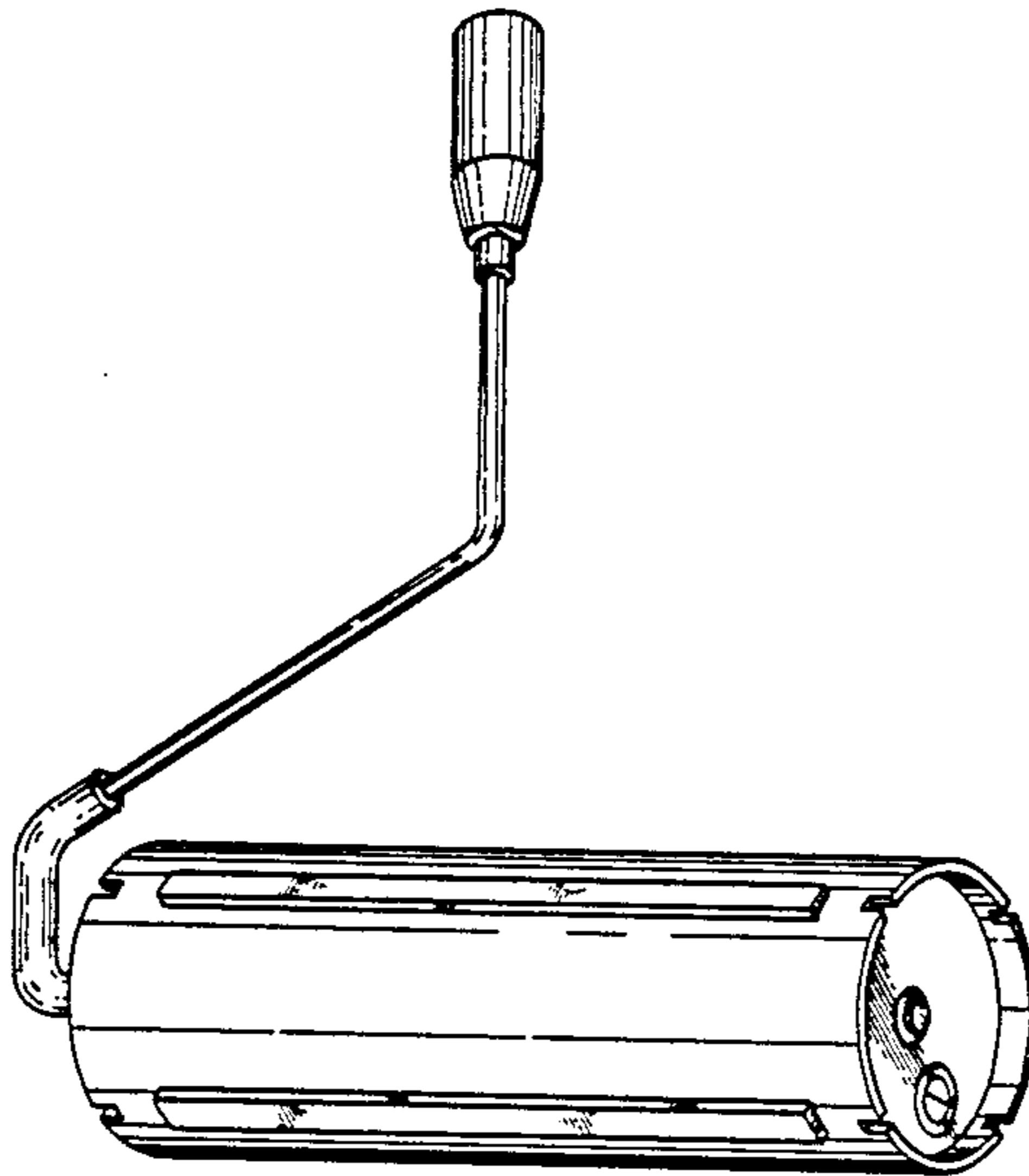

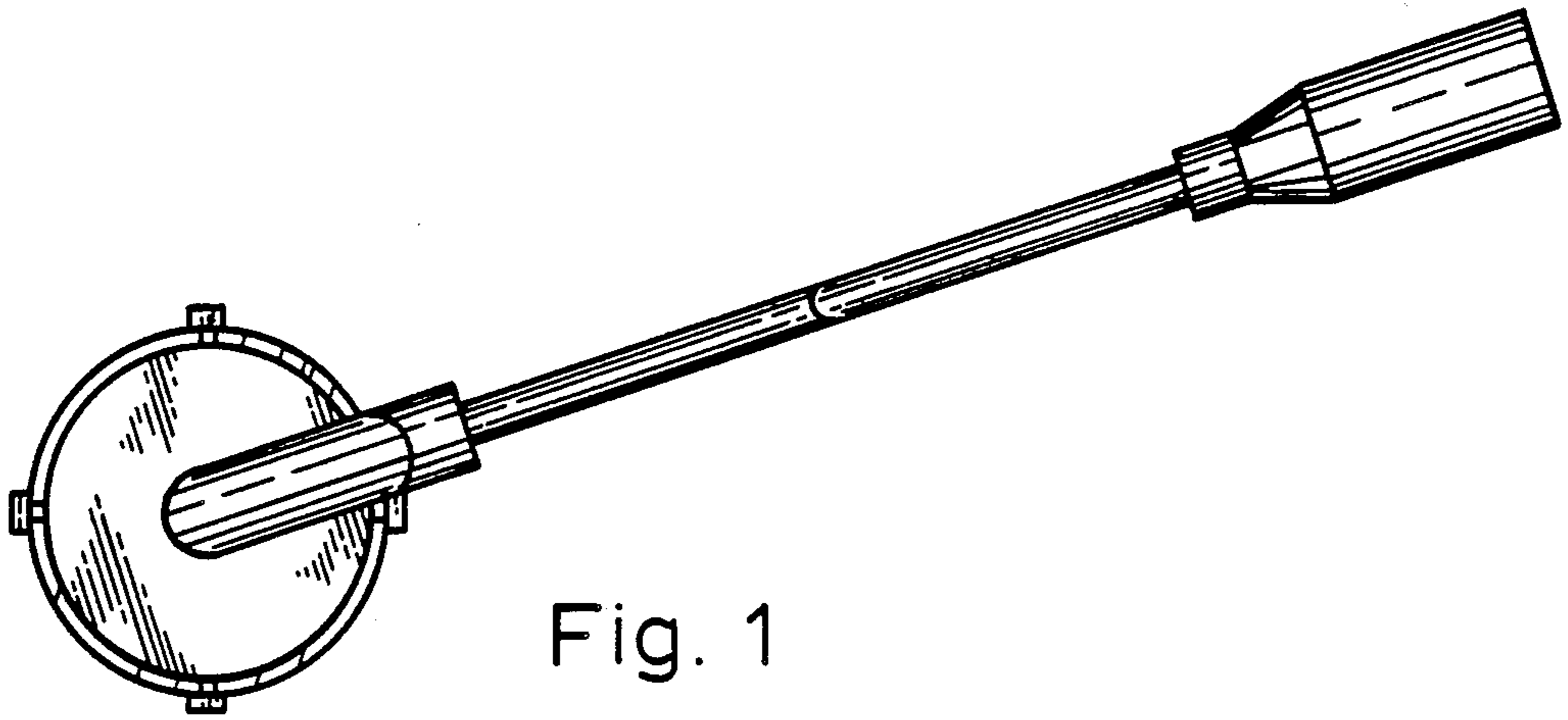

Fig. 1

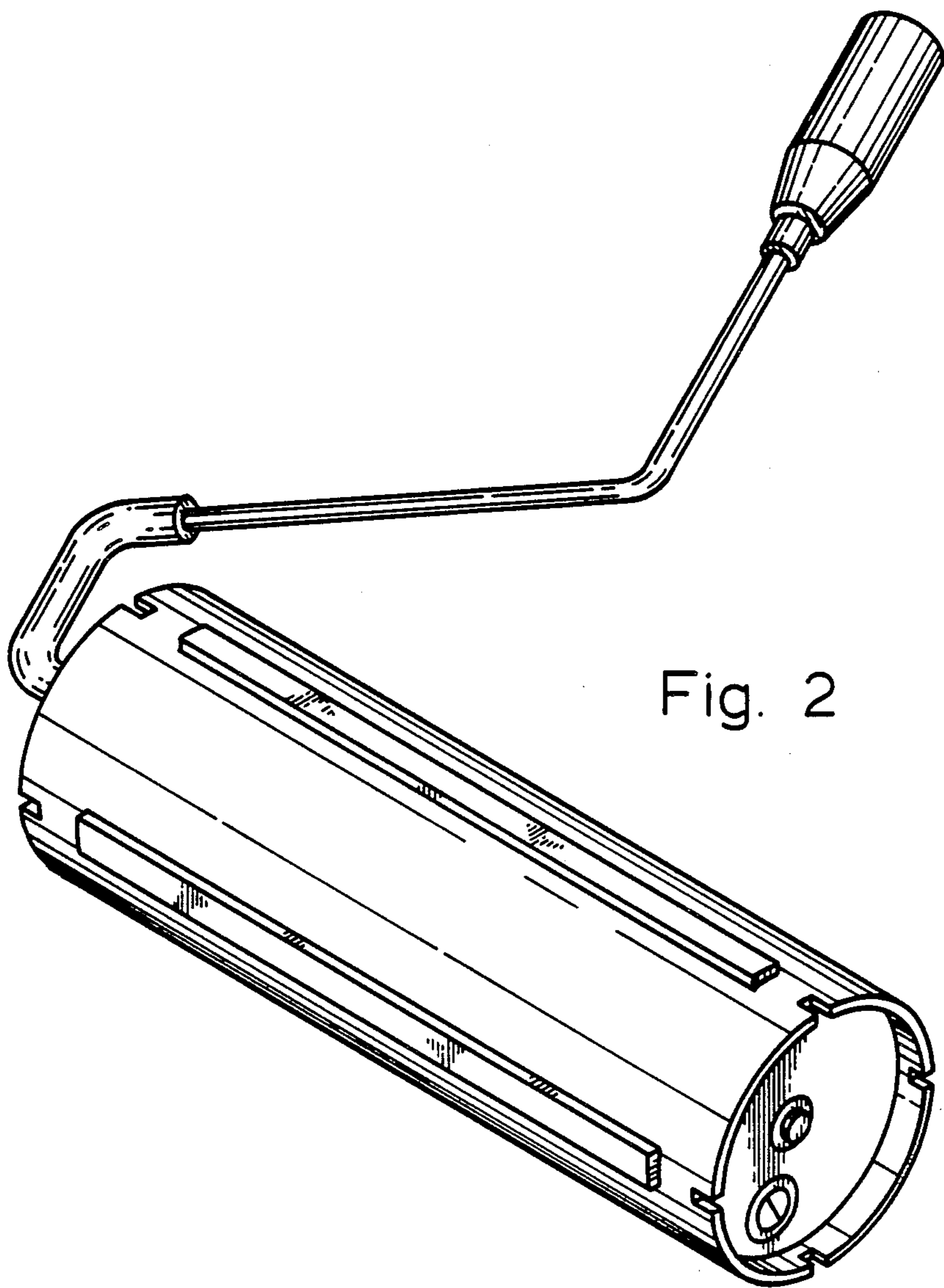

Fig. 2