

[54] STORAGE CONTAINER FOR MOTOR OIL OR THE LIKE

[76] Inventor: Michael H. B. Peters, 3, Olaf Street, London W11 4BE, England

[**] Term: 14 Years

[21] Appl. No.: 635,701

[22] Filed: Jul. 26, 1984

[30] Foreign Application Priority Data

Feb. 2, 1984 [GB] United Kingdom 1017664

[52] U.S. Cl. D9/376; D7/317; D7/319; D9/378

[58] Field of Search D9/378, 382, 377, 376, D9/403, 413, 406; D7/312, 316-322, 300, 70, 50, 76; 220/94 A

[56] References Cited

U.S. PATENT DOCUMENTS

D. 192,438 3/1962 Torongo D7/321

D. 199,505 11/1964 Swett et al. D7/76
D. 203,226 12/1965 Schnur et al. D9/378
D. 211,503 6/1968 Anderson D9/376
D. 237,143 10/1975 Bjork D9/425
2,932,423 4/1960 Baumgartner D7/70 X

Primary Examiner—Winifred E. Herrmann
Attorney, Agent, or Firm—Herbert L. Lerner; Laurence A. Greenberg

[57] CLAIM

The ornamental design for a storage container for motor oil or the like, as shown and described.

DESCRIPTION

FIG. 1 is a rear-elevational view of a storage container for motor oil or the like showing my new design; FIG. 2 is a front-elevational view thereof; FIG. 3 is a left-side perspective view thereof; FIG. 4 is another left-side perspective view thereof; FIG. 5 is a top-plan view thereof; FIG. 6 is a bottom-plan view thereof; and FIG. 7 is a right-side elevational view thereof.

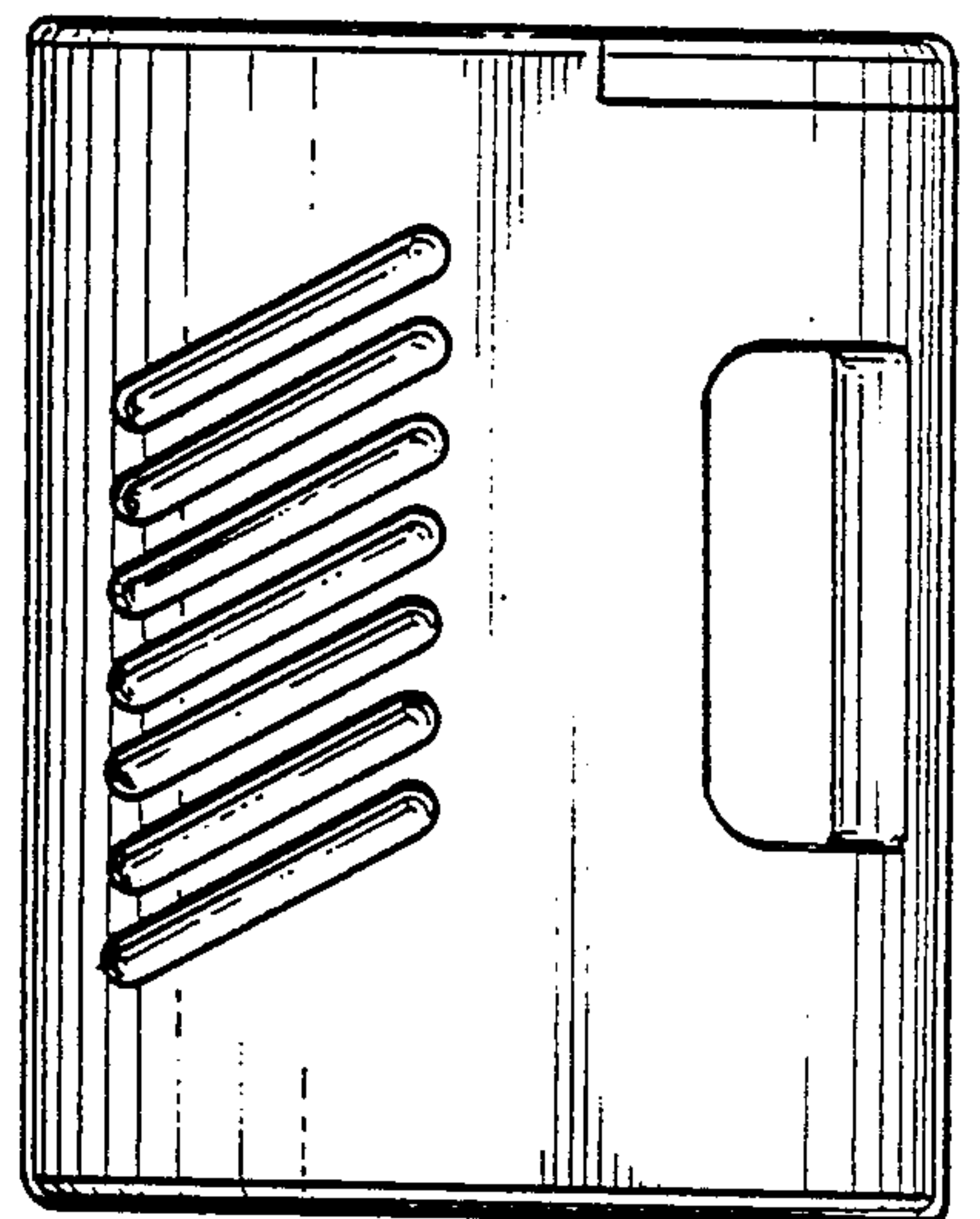
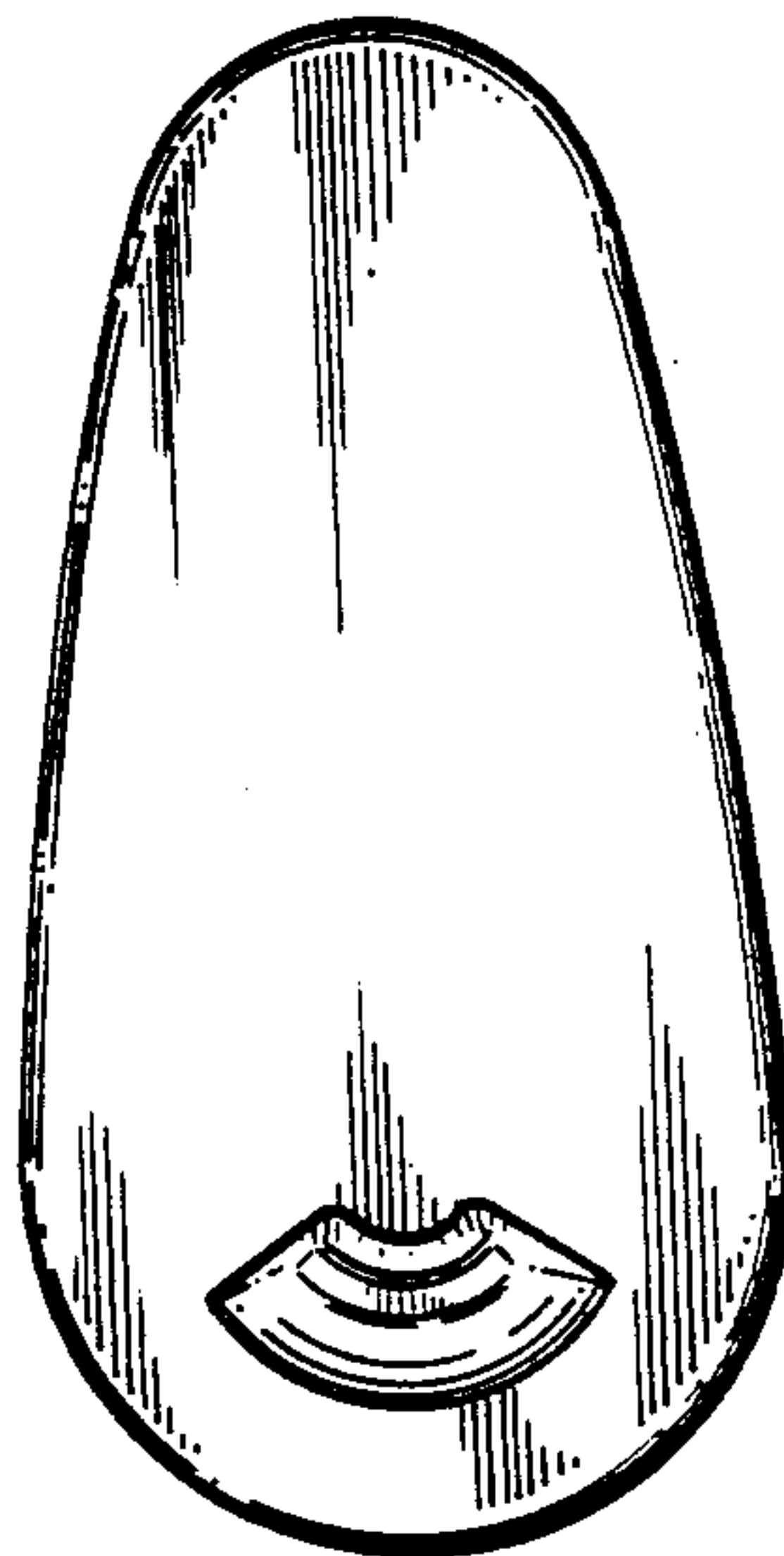
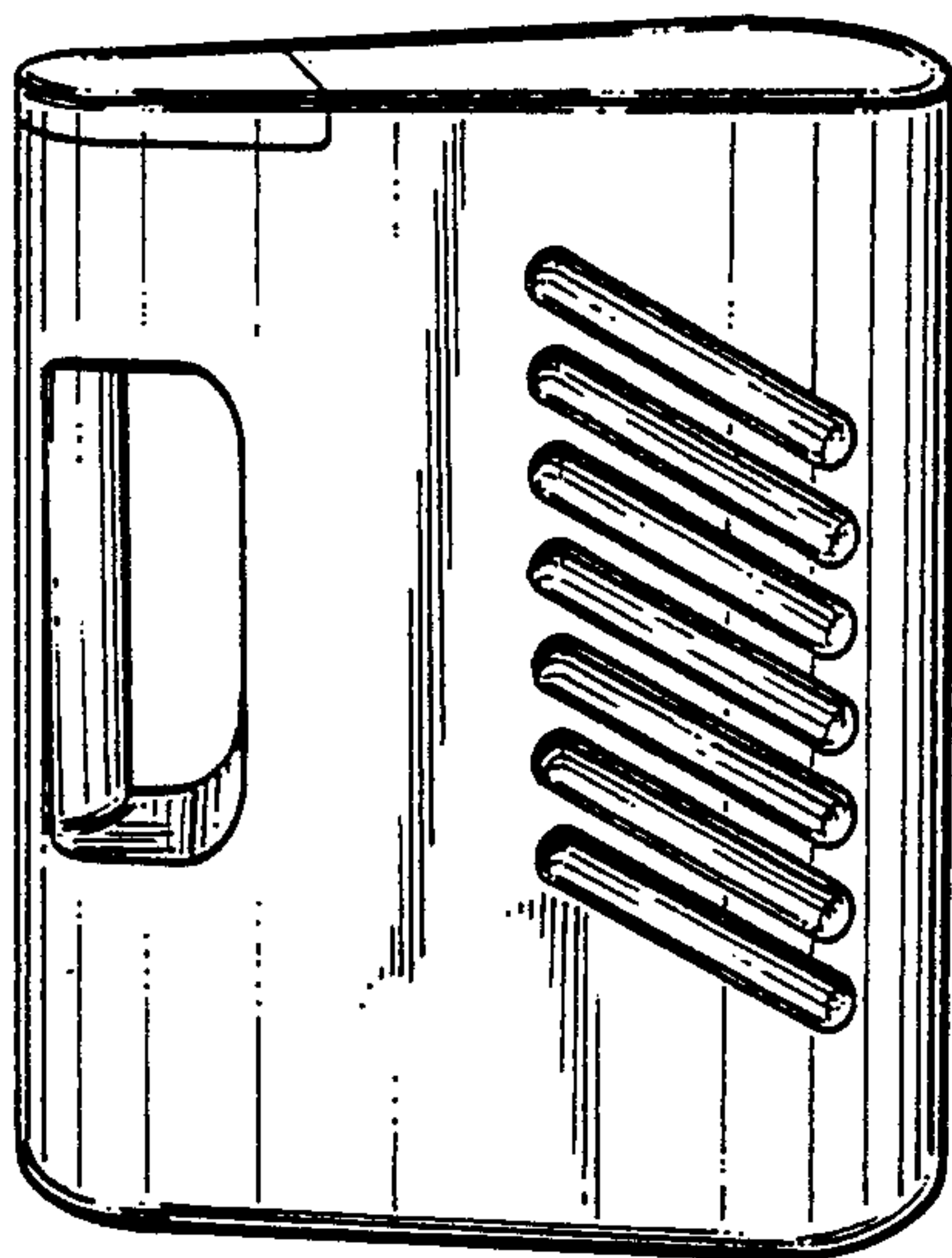

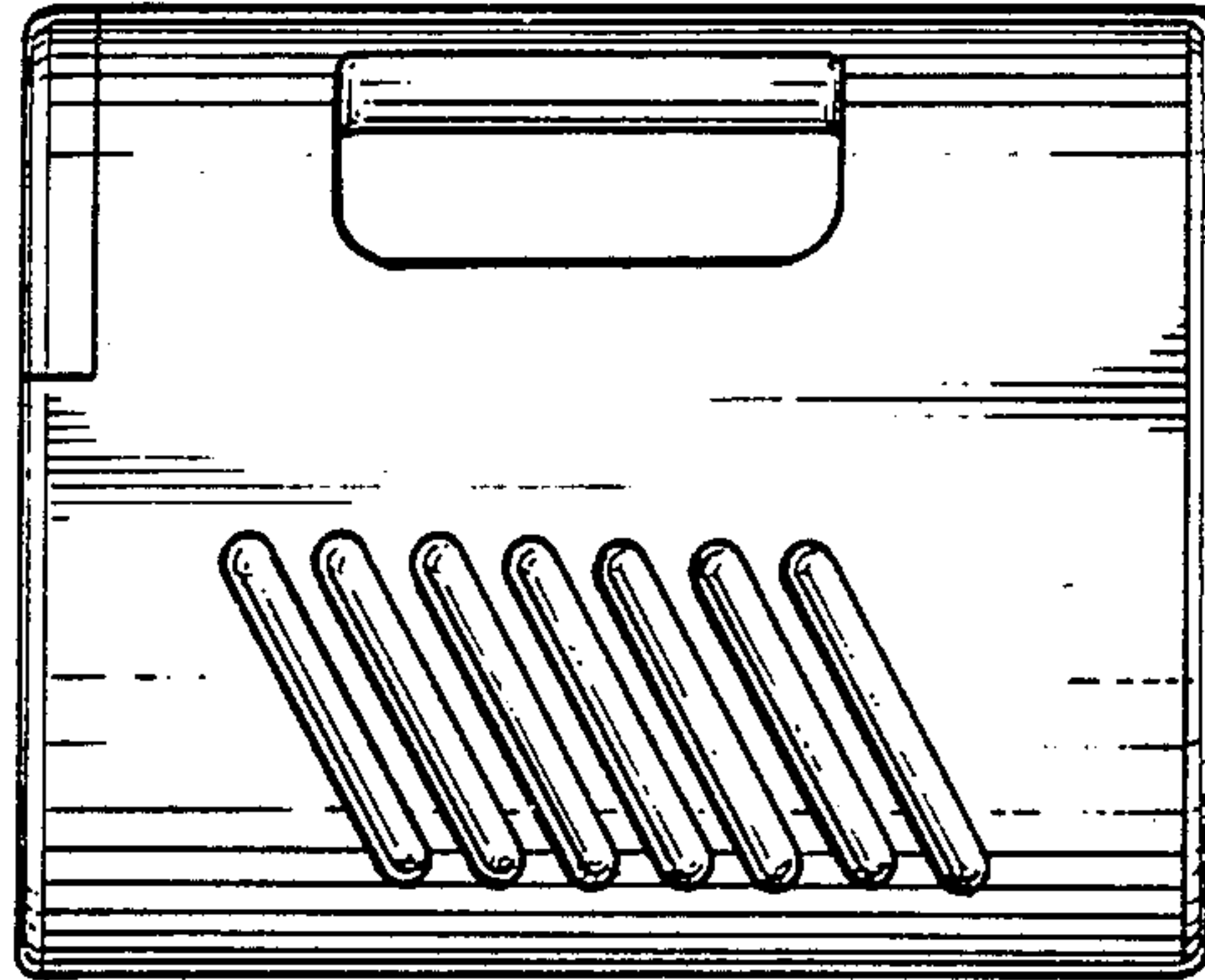

FIG. 7

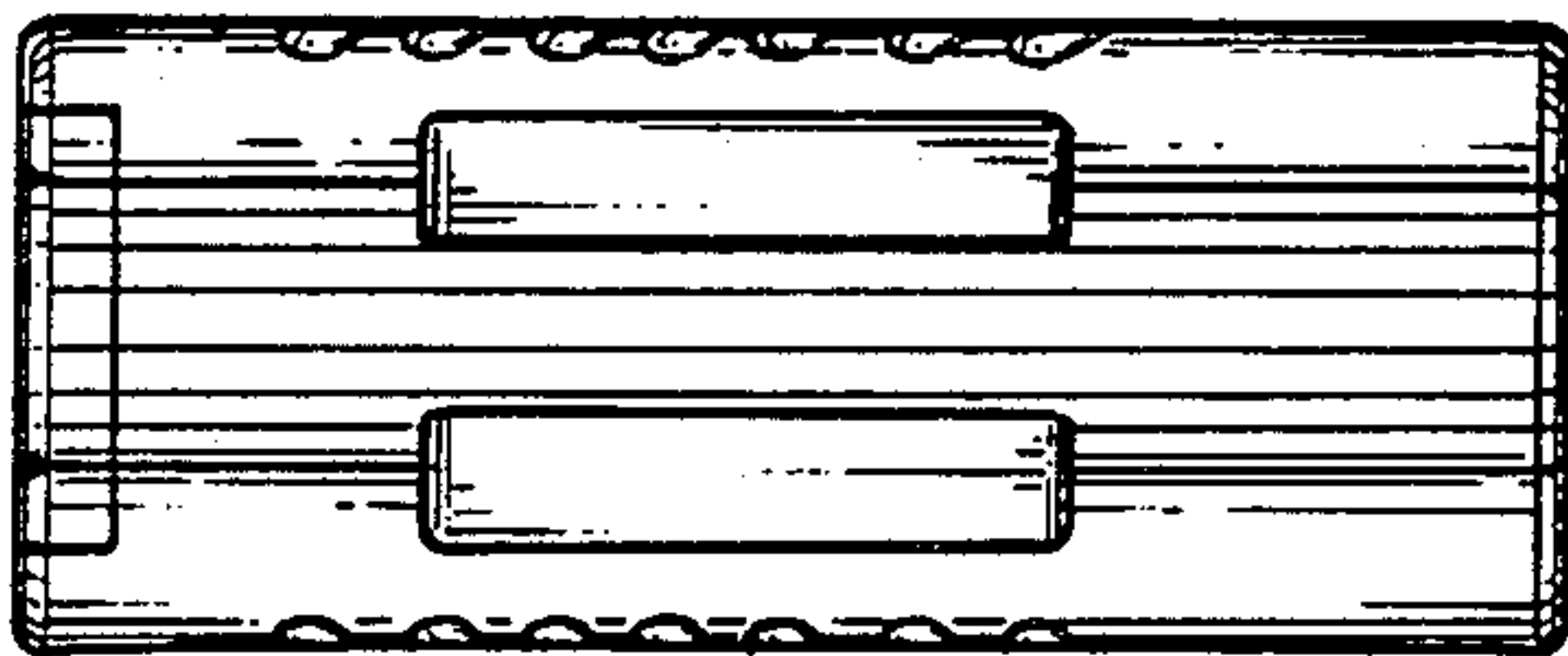

FIG. 2

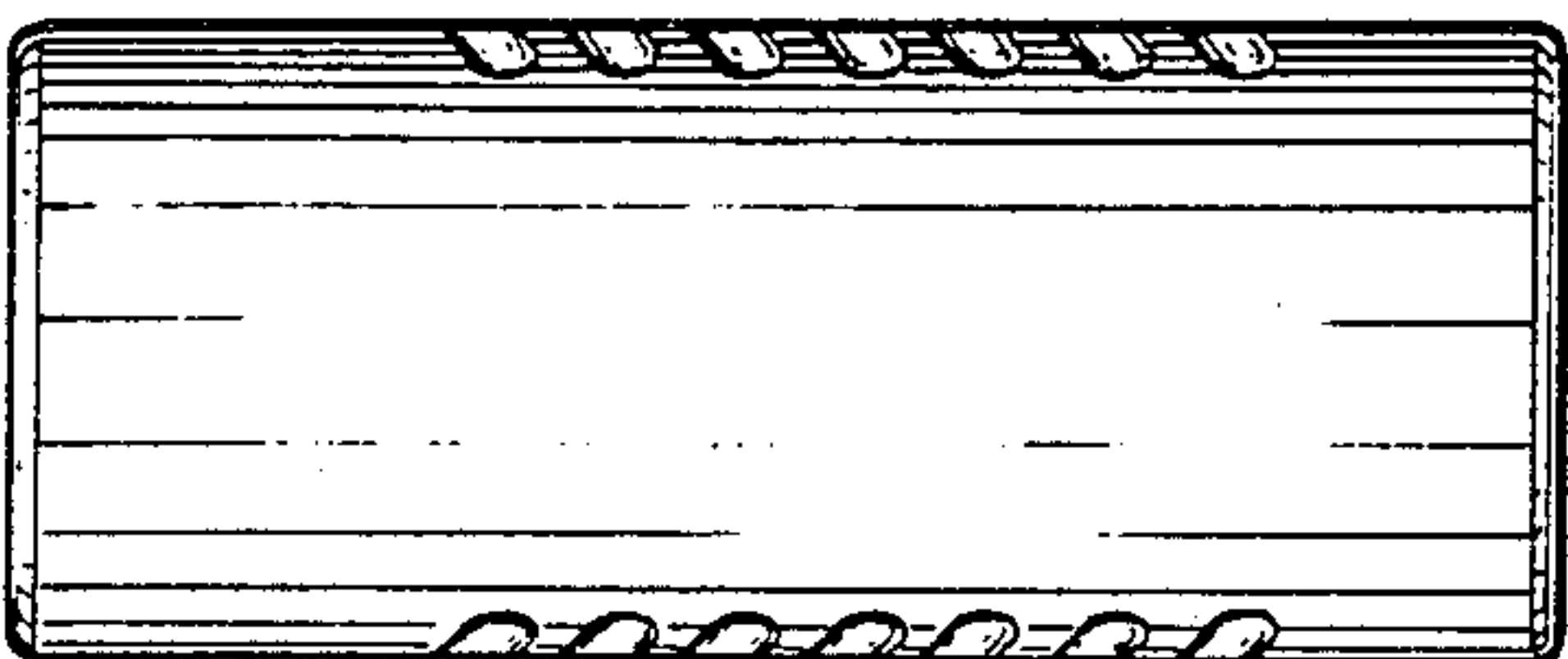

FIG. 1

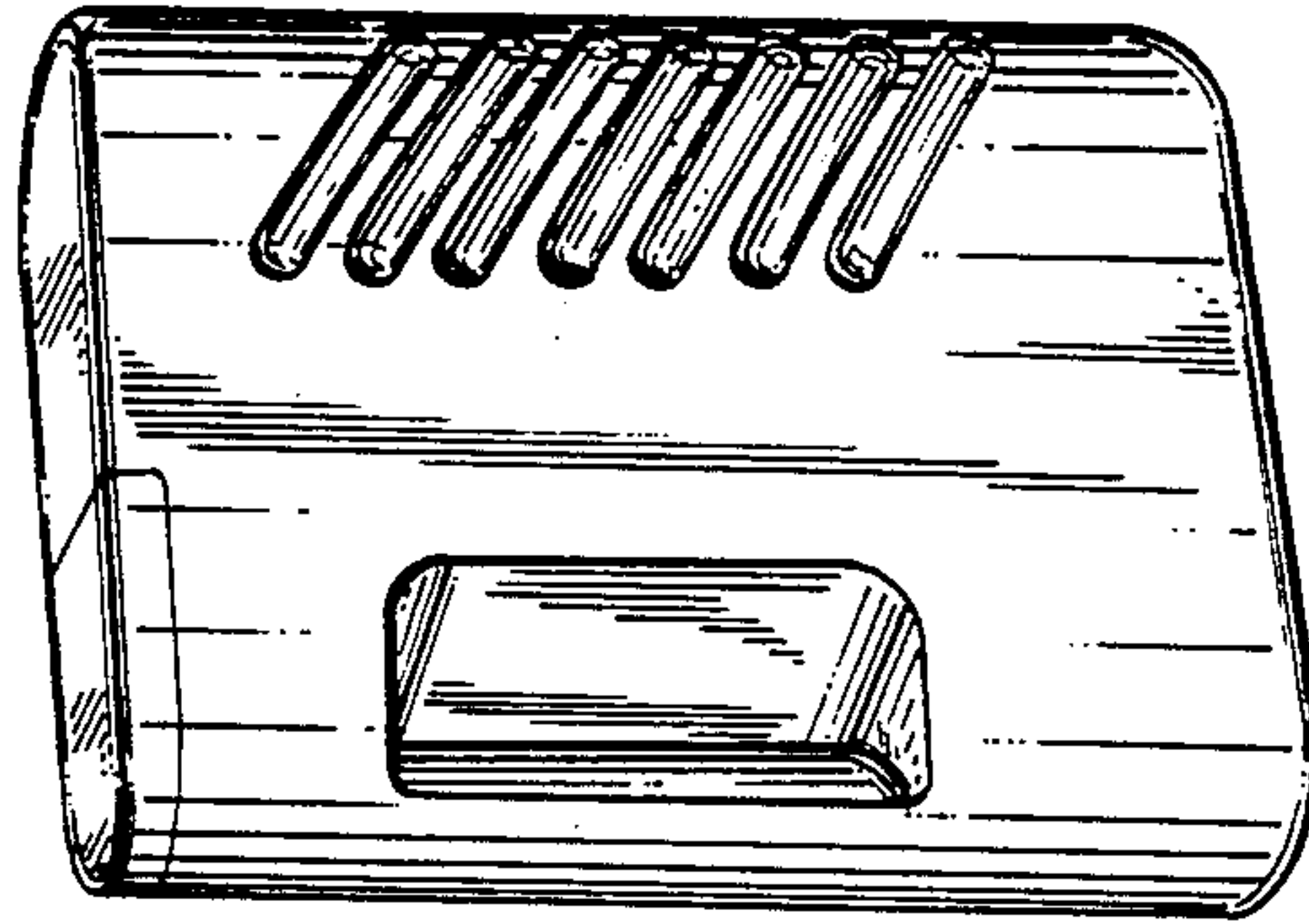

FIG. 4

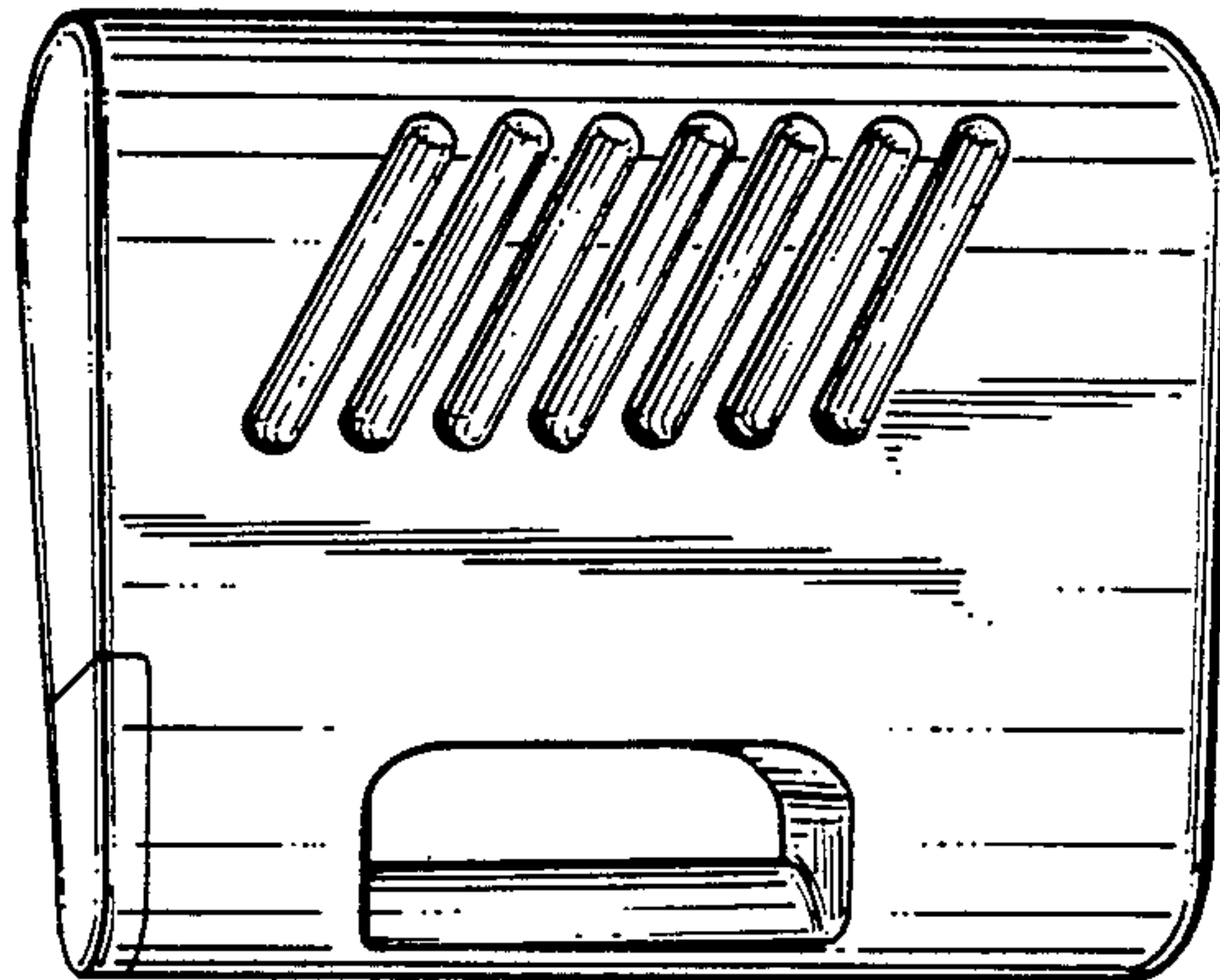

FIG. 3

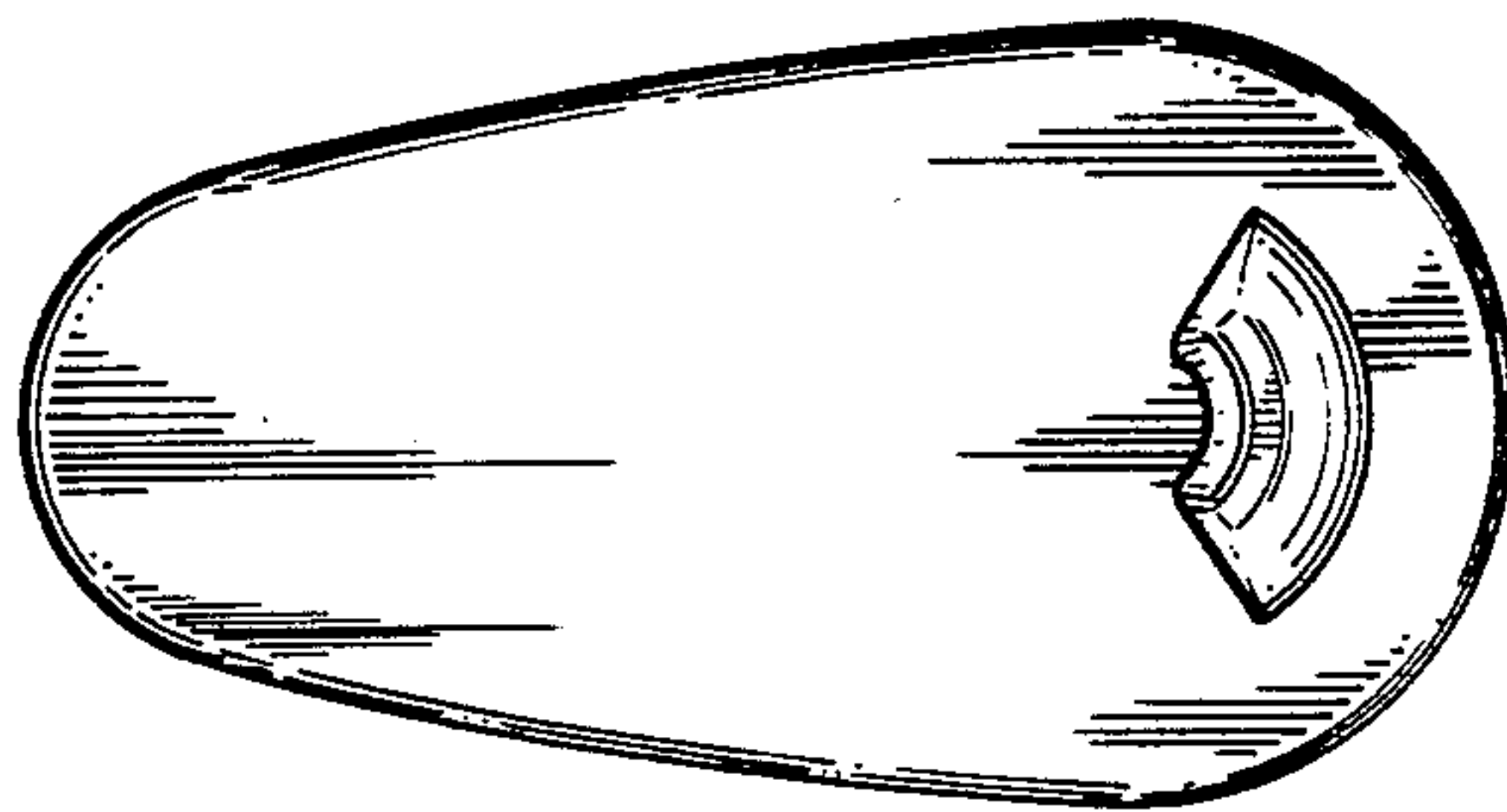

FIG. 6

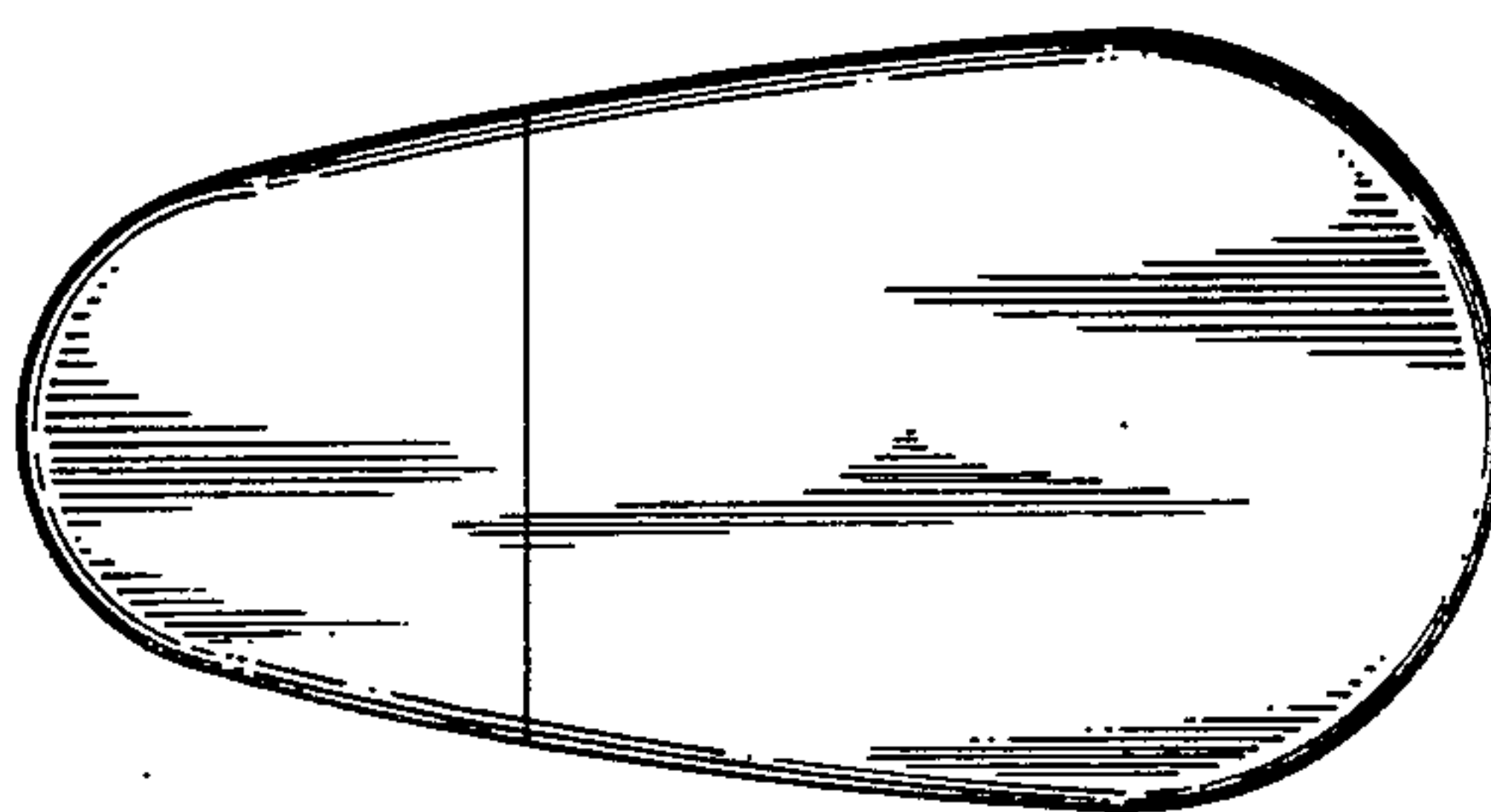

FIG. 5