

[54] TIRE

557976 8/1956 Italy 152/209 R
422304 5/1951 Japan .

[75] Inventors: Keizi Fuzioka; Hitoo Umemoto, both
of Kishiwada, Japan

[73] Assignee: The Ohtsu Tire & Rubber Co., Ltd.,
Osaka, Japan

[**] Term: 14 Years

[21] Appl. No.: 709,151

[22] Filed: Mar. 7, 1985

[52] U.S. Cl. D12/139

[58] Field of Search D12/136, 139;
152/209 R, 209 D

[56] References Cited

U.S. PATENT DOCUMENTS

588,724	8/1897	Bailey	152/209 R
945,396	1/1910	Kempshall	152/209 R
1,037,686	9/1912	Toomey	152/209 R
3,805,865	4/1974	Price	152/209 R

FOREIGN PATENT DOCUMENTS

32915	4/1963	Finland	152/209 R
-------	--------	---------------	-----------

OTHER PUBLICATIONS

Automotive & Aviation Industries, 11/43, p. 68, U.S.
Royal Smooth Contour Ice Grip Tire, center right side
of page.

Advertisement in *Dirt Wheels Magazine*, Aug., 1984
entitled "A Legend in the Making—Dunlop ATV
Tires".

Primary Examiner—James M. Gandy
Attorney, Agent, or Firm—Armstrong, Nikaido,
Marmelstein & Kubovcik

[57] CLAIM

The ornamental design for a tire, as shown and de-
scribed.

DESCRIPTION

FIG. 1 is a perspective view of a tire showing our new
design, it being understood that the tread pattern is
repeated throughout the circumference of the tire and
the opposite side is substantially the same as that shown.
FIG. 2 is a front elevational view thereof; and
FIG. 3 is a side elevational view thereof.

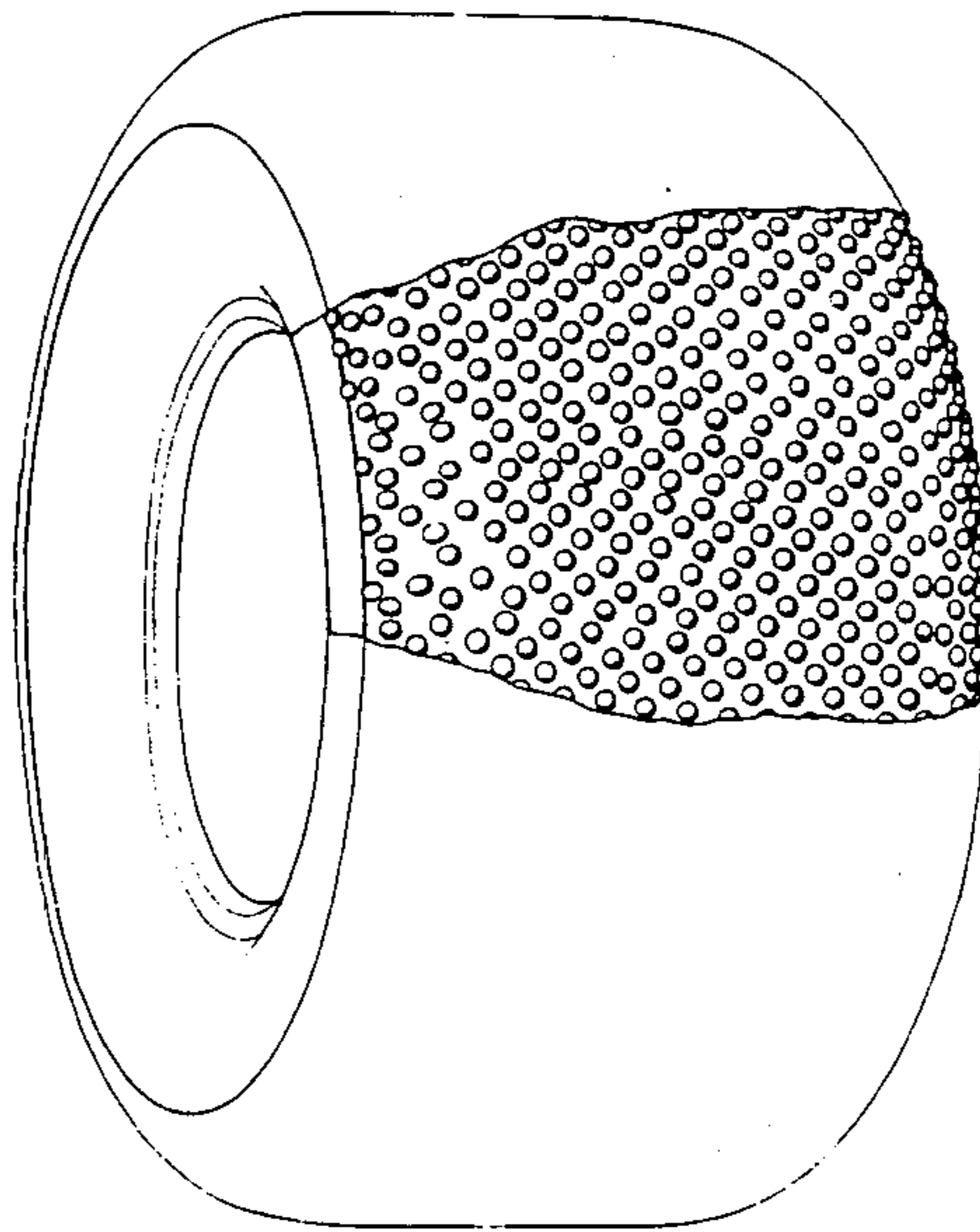

Fig 2

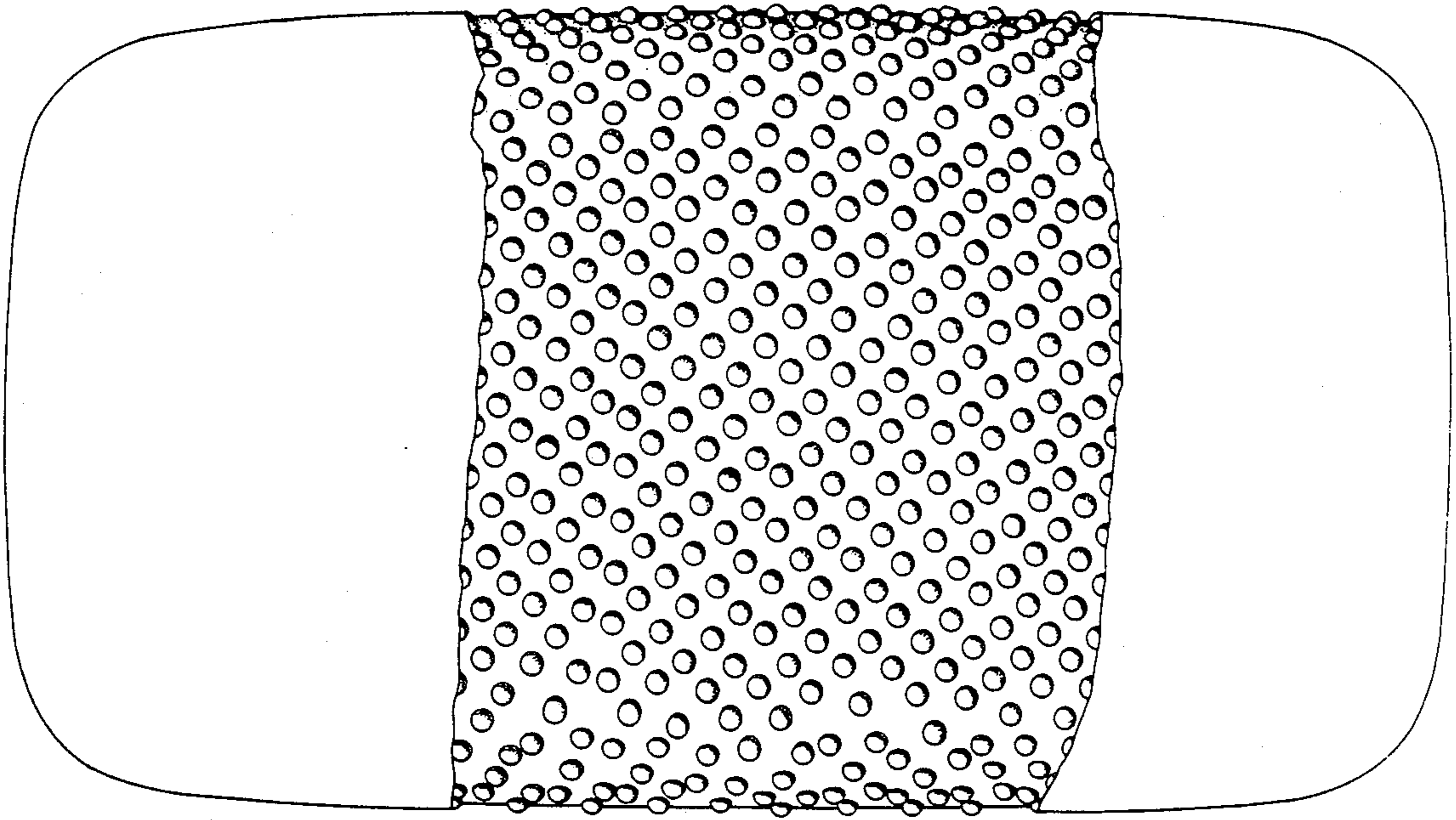
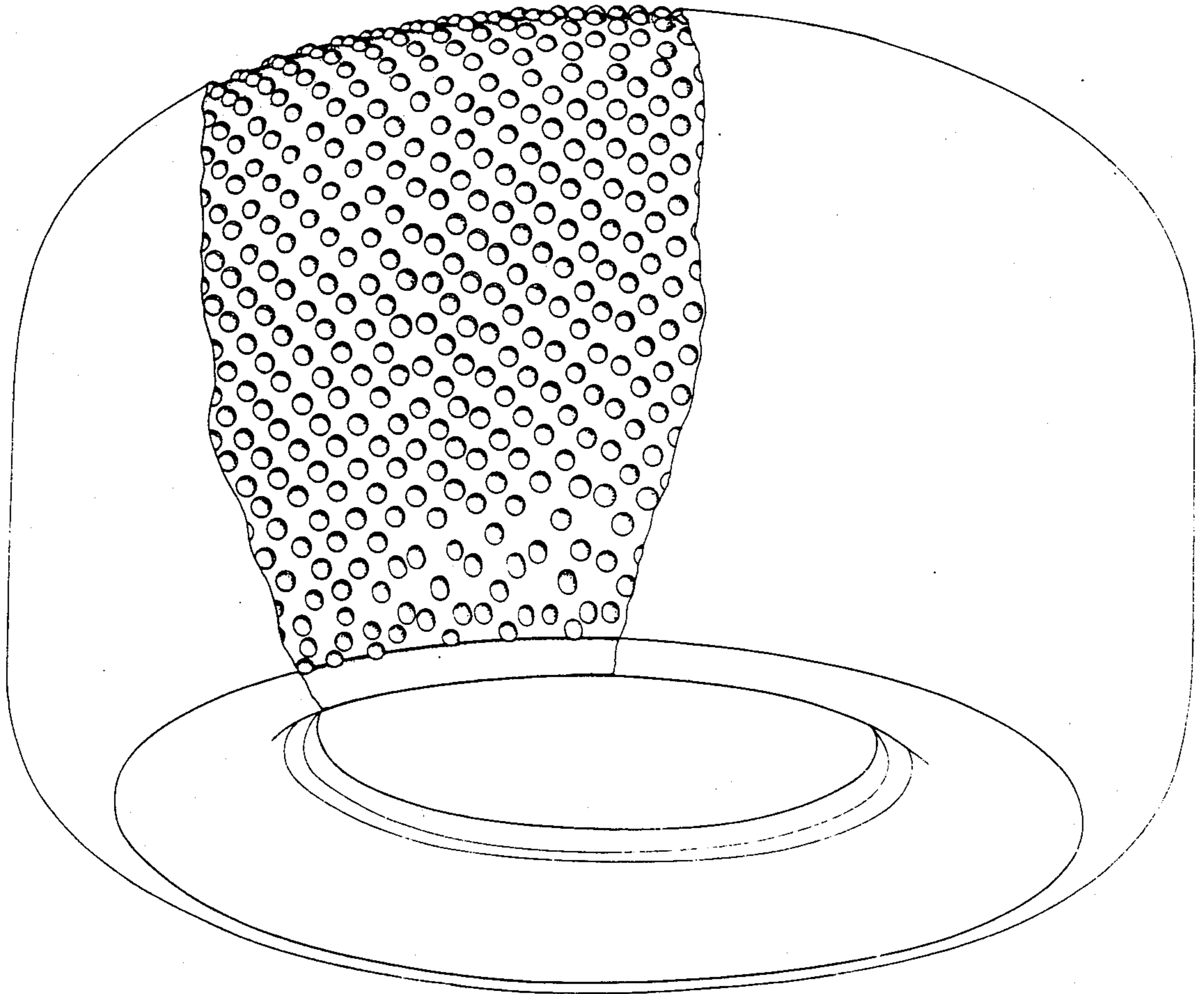

Fig 1



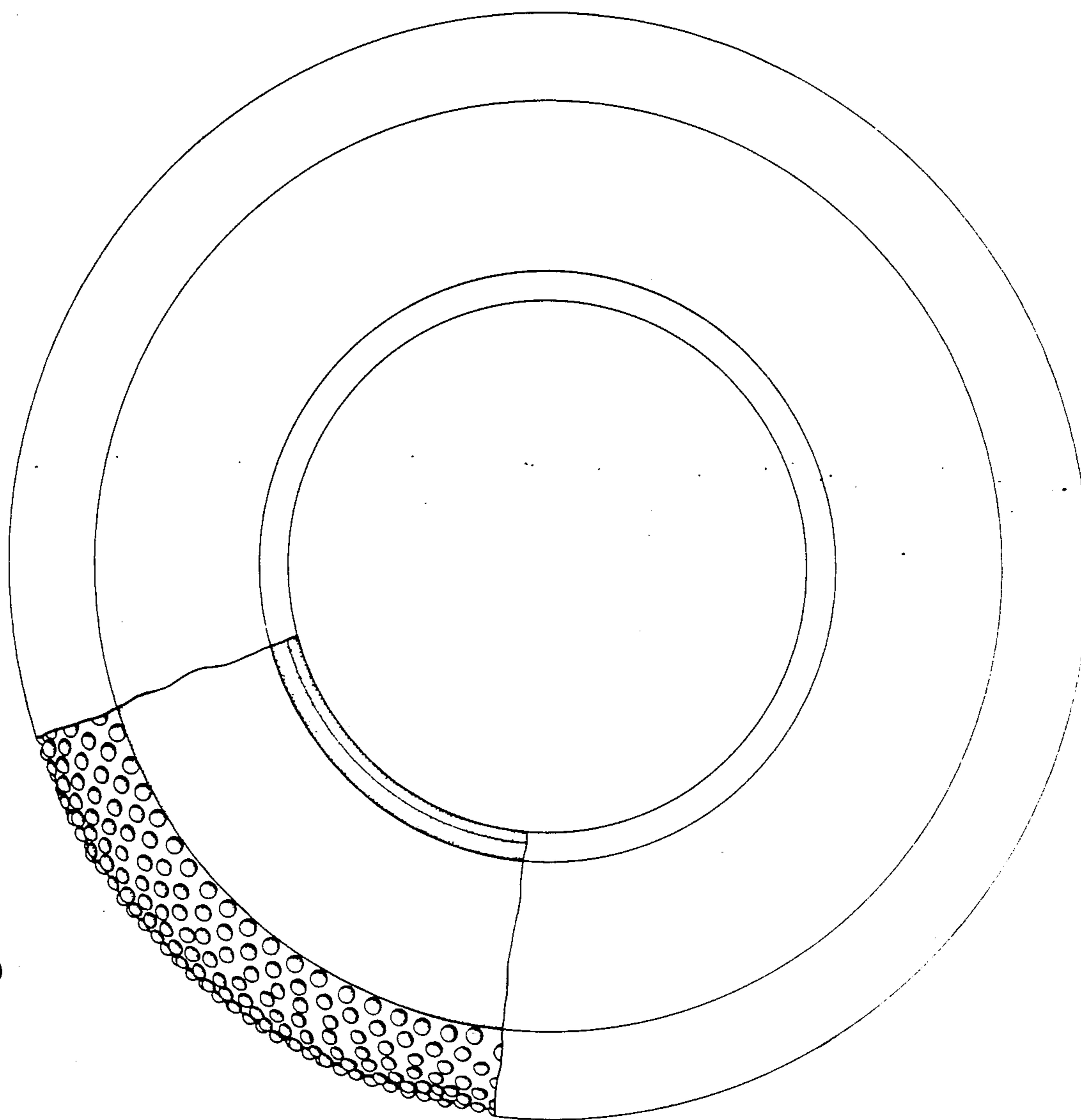

Fig 3