

United States Patent [19]

Kaufmann et al.

[11] Patent Number: **Des. 293,449**

[45] Date of Patent: **** Dec. 29, 1987**

[54] **INDUSTRIAL ROBOT**

[75] Inventors: **Herbert Kaufmann; Torbjörn Forss,**
both of Västerås, Sweden

[73] Assignee: **Asea AB, Västerås, Sweden**

[**] Term: **14 Years**

[21] Appl. No.: **709,347**

[22] Filed: **Mar. 6, 1985**

[30] **Foreign Application Priority Data**

Sep. 24, 1984 [SE] Sweden 84-2532
[52] U.S. Cl. **D15/199; D15/122**
[58] Field of Search **D15/122, 194;**
414/729-742

[56] **References Cited**

U.S. PATENT DOCUMENTS

D. 279,571 7/1985 Arai et al. D15/122

D. 287,368 12/1986 Shibayama et al. D15/199
3,703,968 11/1972 Urich et al. 414/738
4,460,302 7/1984 Moreau et al. 414/749
4,501,522 2/1985 Causer et al. 414/735

Primary Examiner—B. J. Bullock
Attorney, Agent, or Firm—Young & Thompson

[57] **CLAIM**

The ornamental design for an industrial robot, as shown and described.

DESCRIPTION

FIG. 1 is a left side perspective view of an industrial robot embodying our new design;
FIG. 2 is a rear elevational view with the arm in an alternate position;
FIG. 3 is a front elevational view of FIG. 2;
FIG. 4 is a bottom plan view of FIG. 2;
FIG. 5 is a top plan view of FIG. 2;
FIG. 6 is a left side elevational view of FIG. 2, the right side being a mirror image.

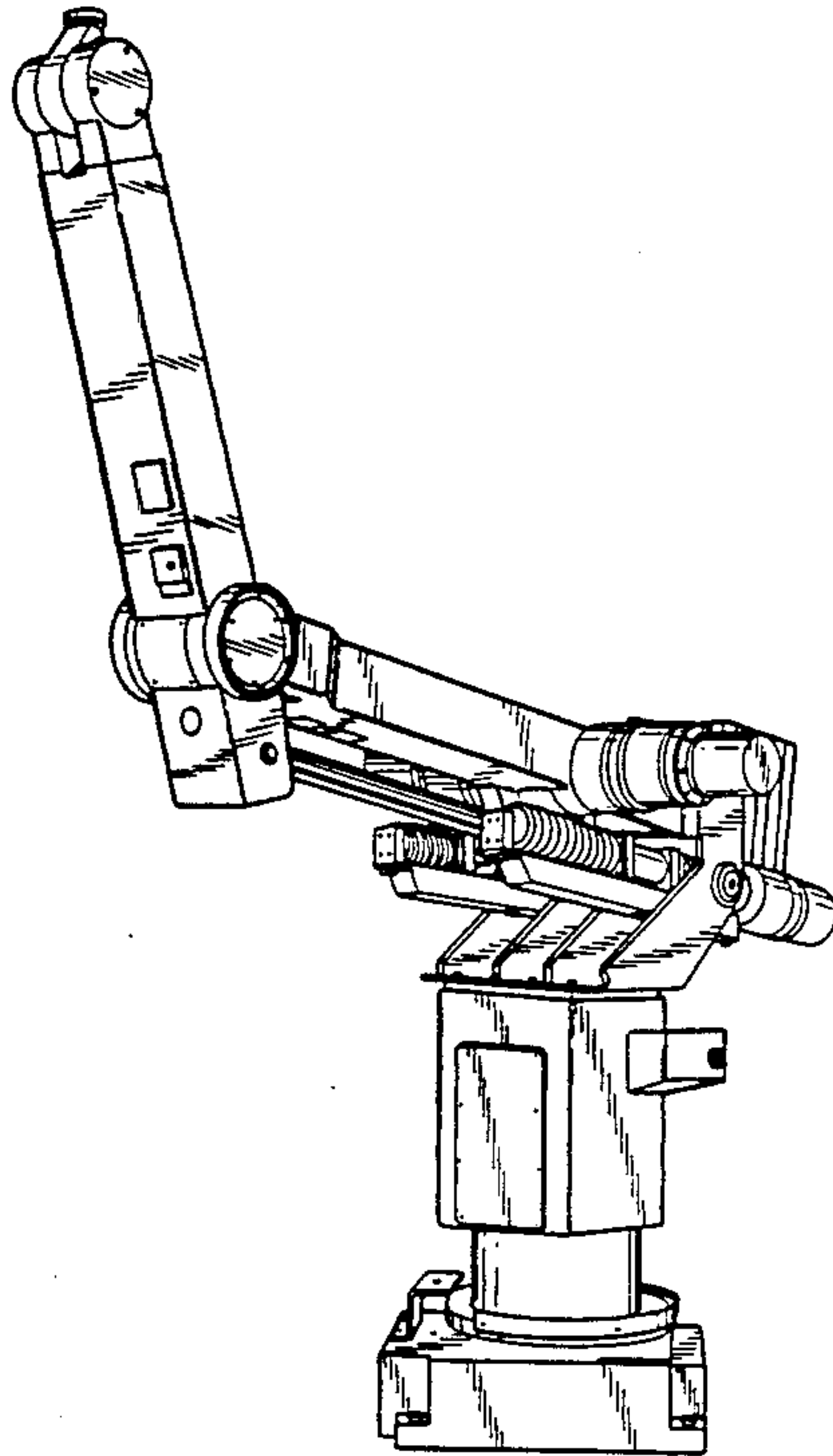

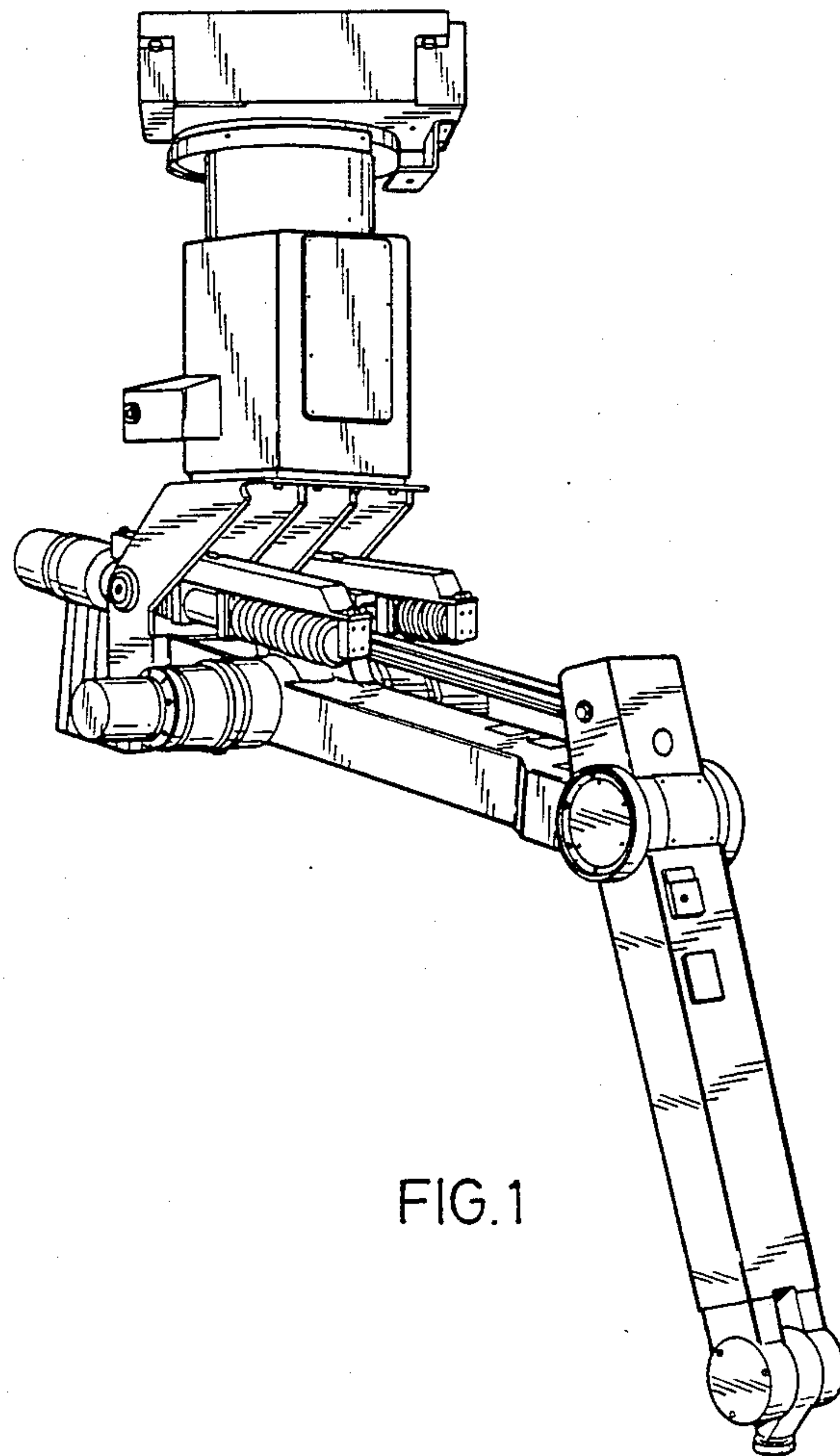
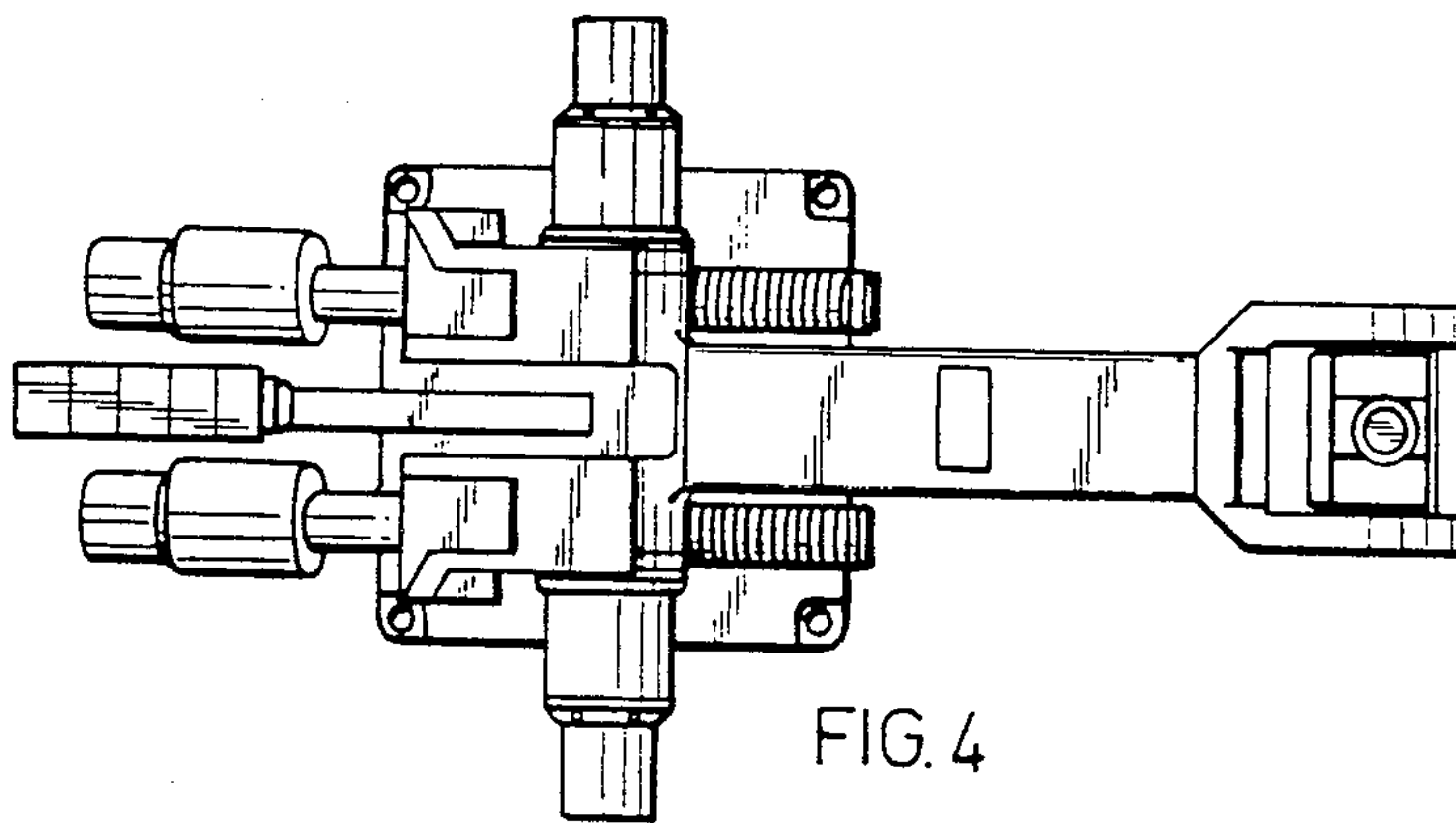
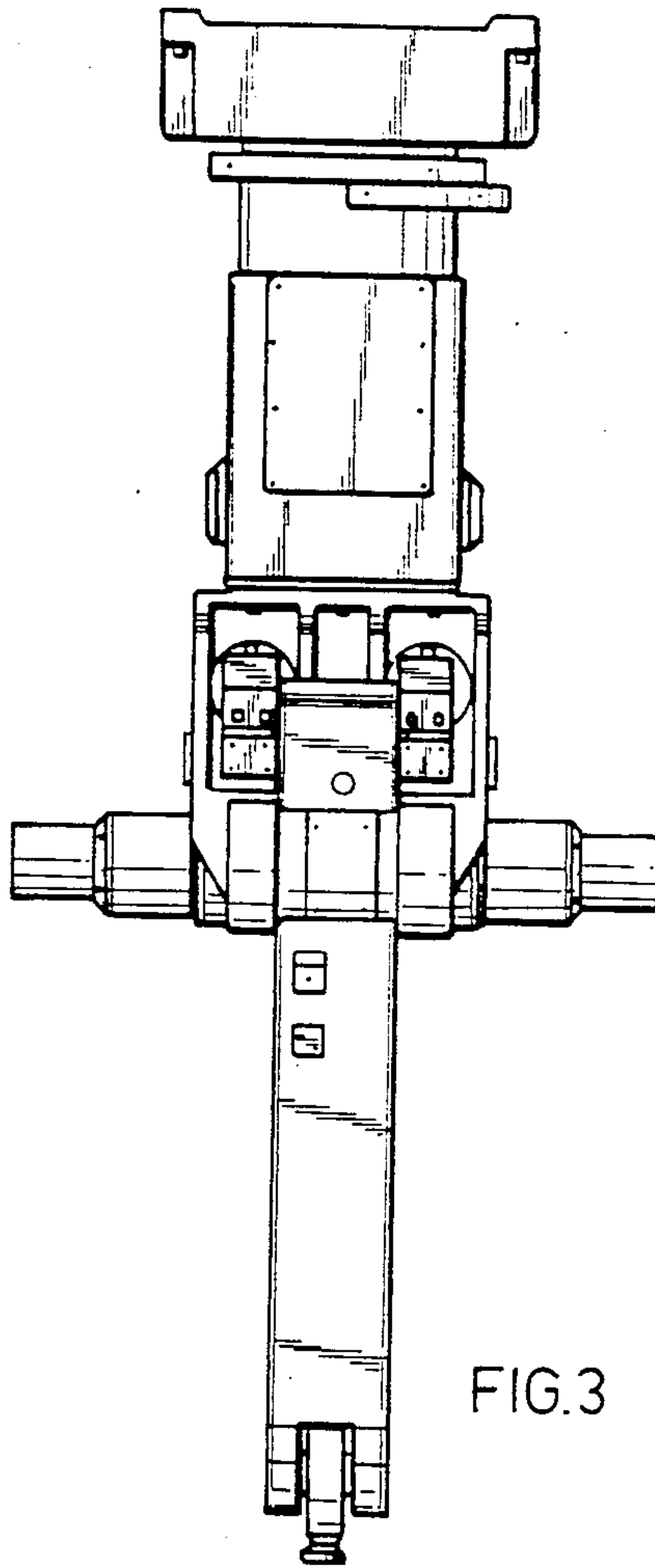
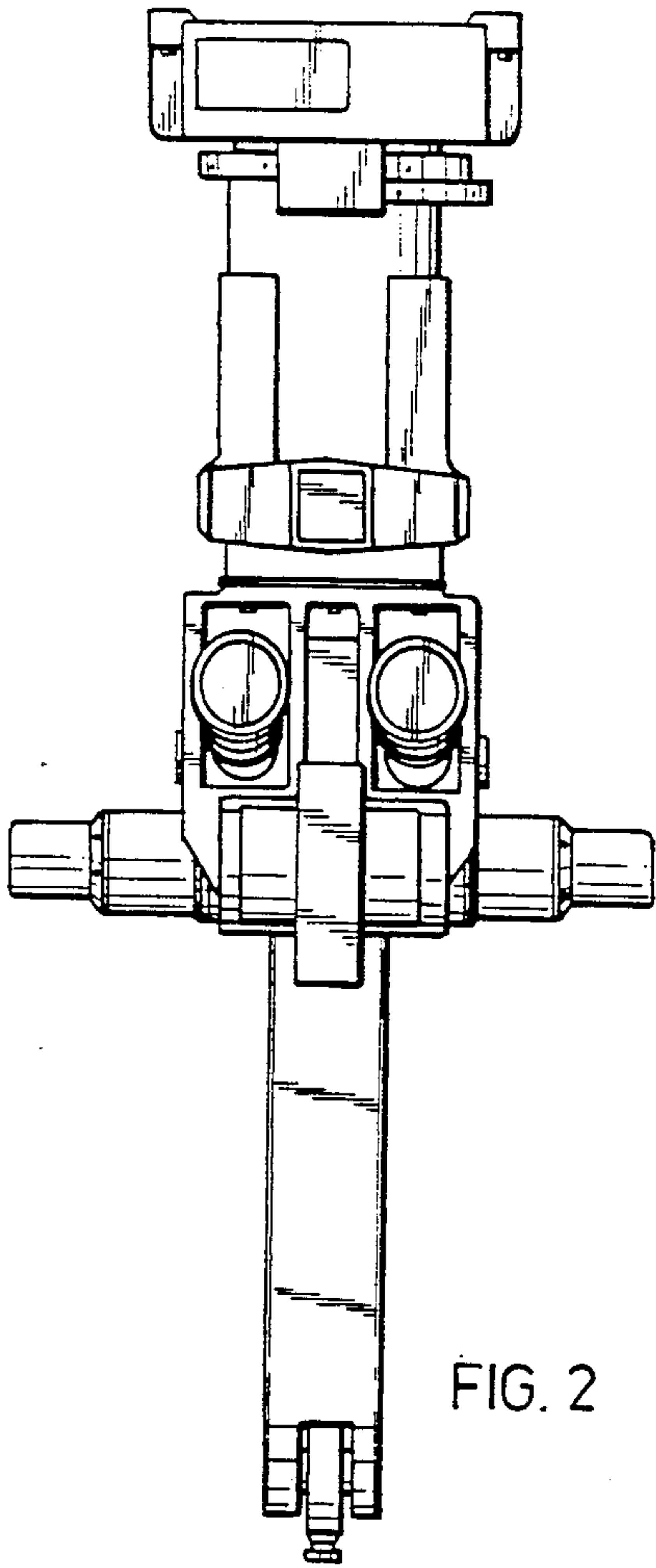

FIG. 1



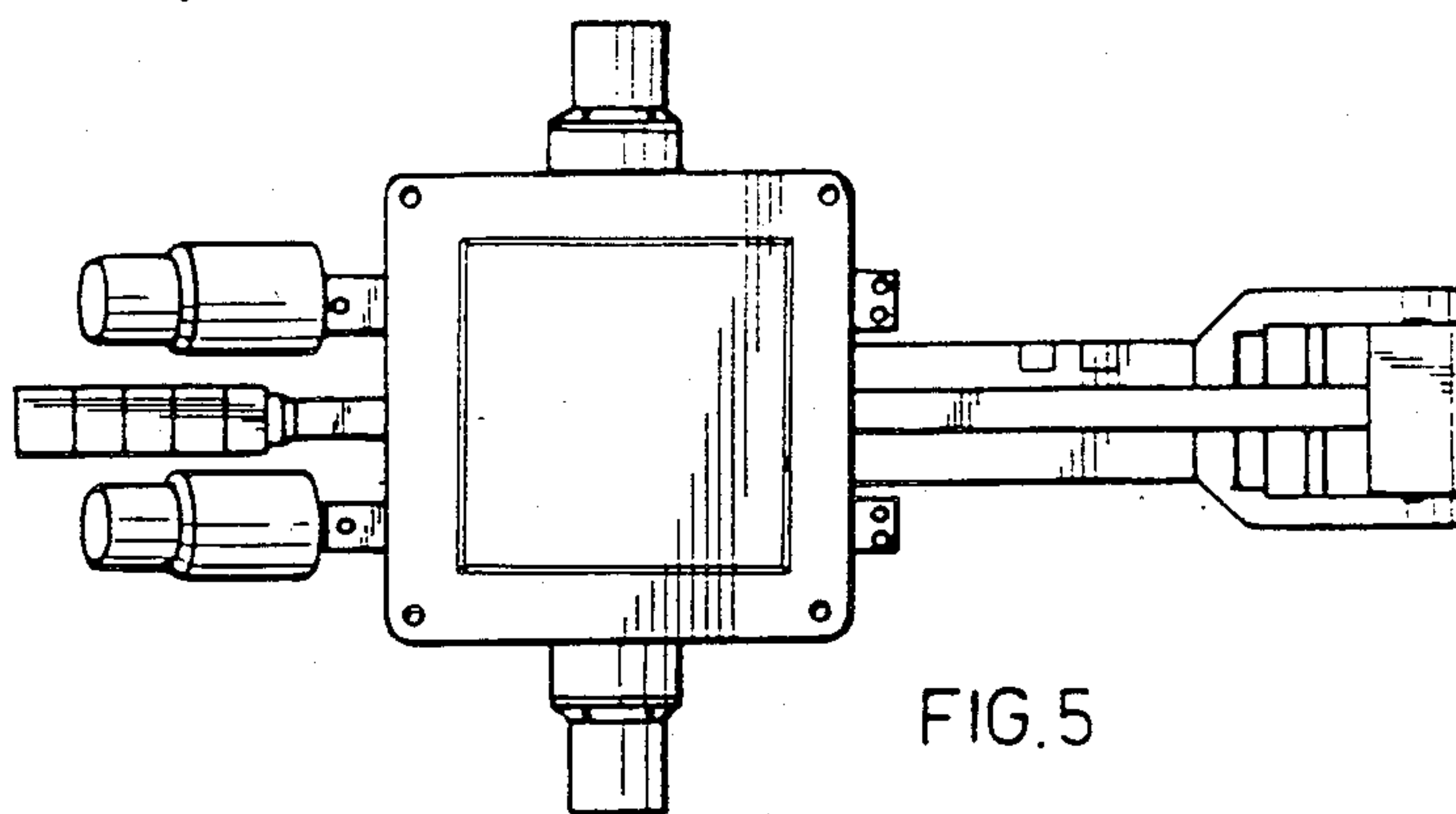

FIG. 5

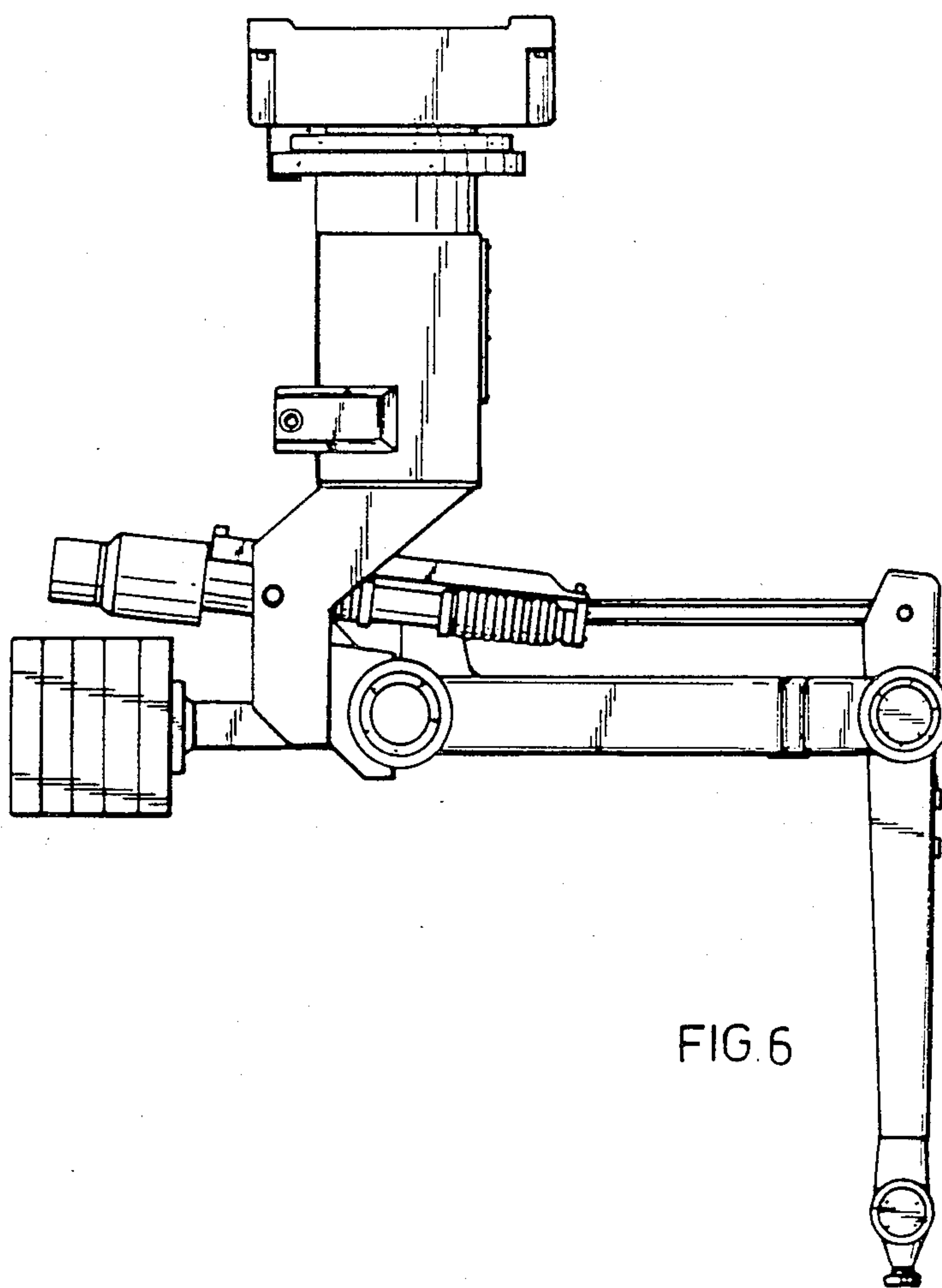

FIG. 6