

[54] **PERISTROPHIC-WING AIR CRAFT**

[76] **Inventor: Theodore Koutsoupidis, Kecropos 39, Glyfada, Athens 166-75, Greece**

[**] **Term: 14 Years**

[21] **Appl. No.: 864,112**

[22] **Filed: May 16, 1986**

[52] **U.S. CL. D12/338; D12/328; D12/344**

[58] **Field of Search D12/319, 327, 328, 329, D12/338, 339, 344; 244/6, 7 R, 91, 199**

[56] **References Cited**

U.S. PATENT DOCUMENTS

D. 218,858 9/1970 Fellers D12/338
D. 271,294 11/1983 Hauk D12/344
3,438,597 4/1969 Kasper 244/91

OTHER PUBLICATIONS

Flight Int'l, Jul. 31, 1982, p. 259, Bell's Tilt-Rotor JUX medium-left Rotorcraft unfolded (top).

Primary Examiner—James M. Gandy
Assistant Examiner—Kay H. Chin

[57] **CLAIM**

The ornamental design for a peristrophic-wing air craft substantially as shown and described.

DESCRIPTION

FIG. 1 is a perspective view of a peristrophic-wing air craft showing my new design;
FIG. 2 is a side elevation view thereof;
FIG. 3 is a rear elevation view thereof;
FIG. 4 is a front elevation view thereof, with thrust-flaps in extended condition;
FIG. 5 is a front elevation view thereof, with thrust-flaps in tilted condition;
FIG. 6 is a top plan view thereof;
FIG. 7 is an enlarged fragmentary side elevation view thereof showing in greater detail the thrust-flaps in extended condition;
FIG. 8 is an enlarged fragmentary side elevation view thereof, showing in greater detail the thrust-flaps in tilted condition;
FIG. 9 is a bottom plan view thereof.

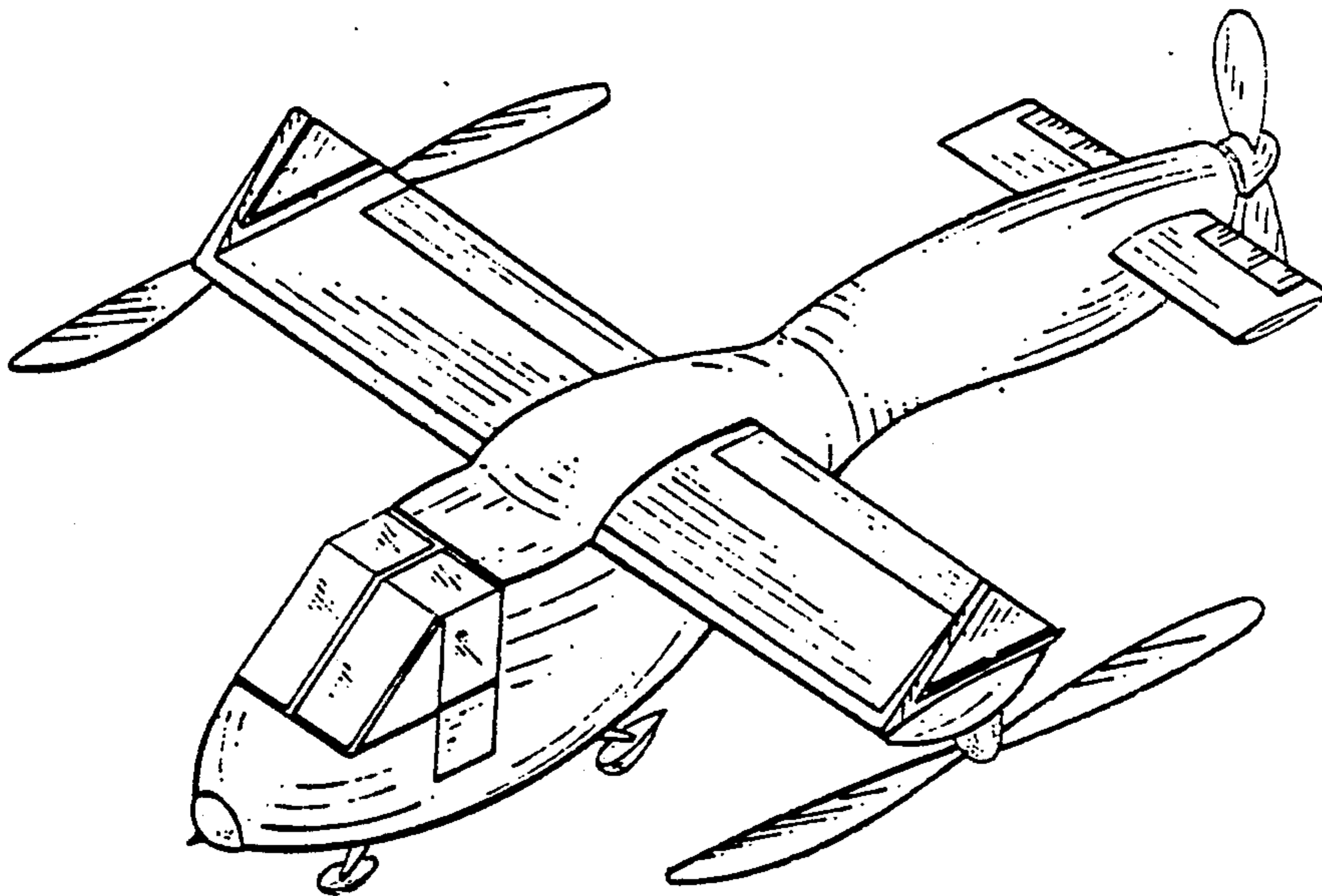

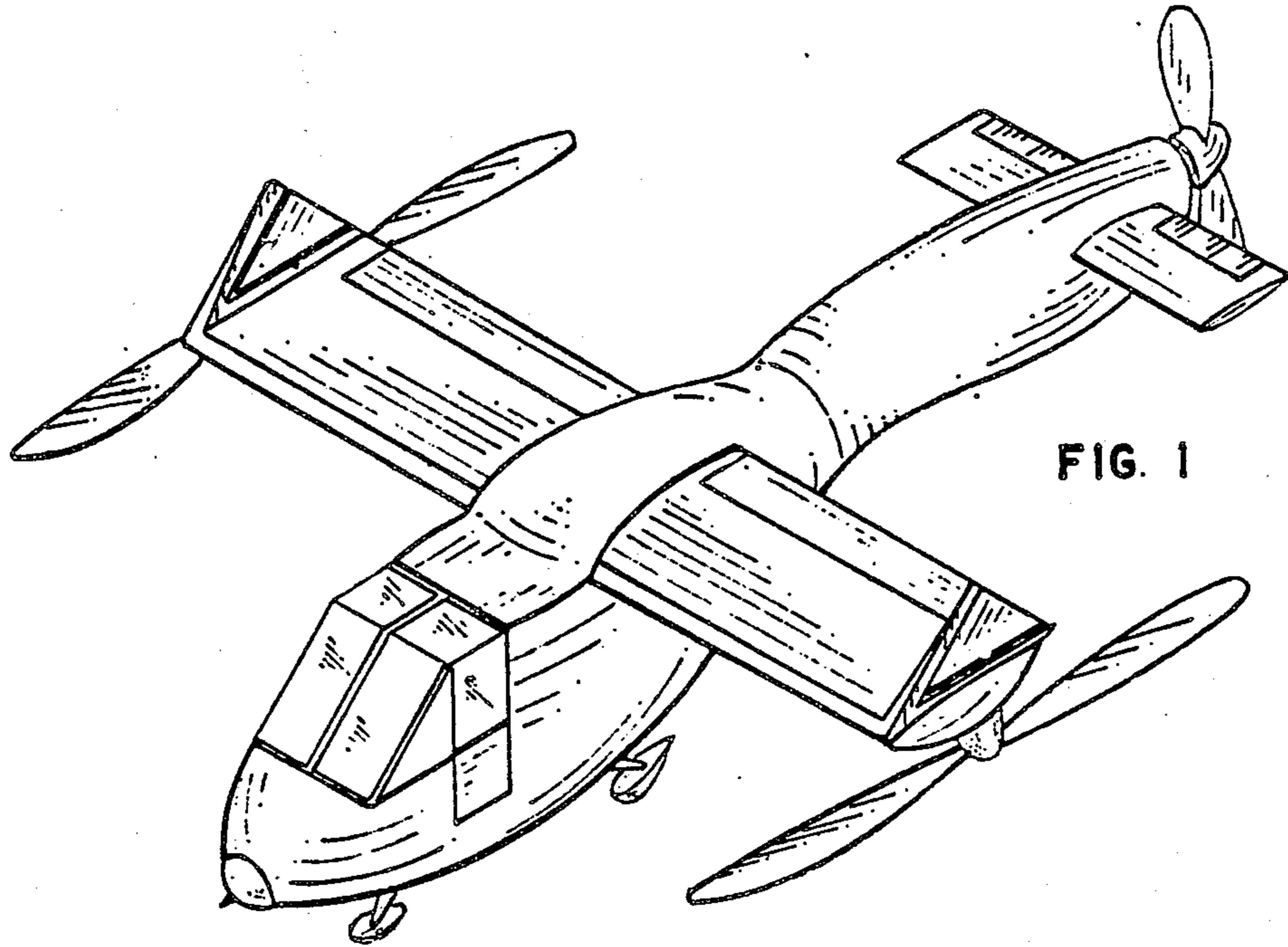

FIG. 1

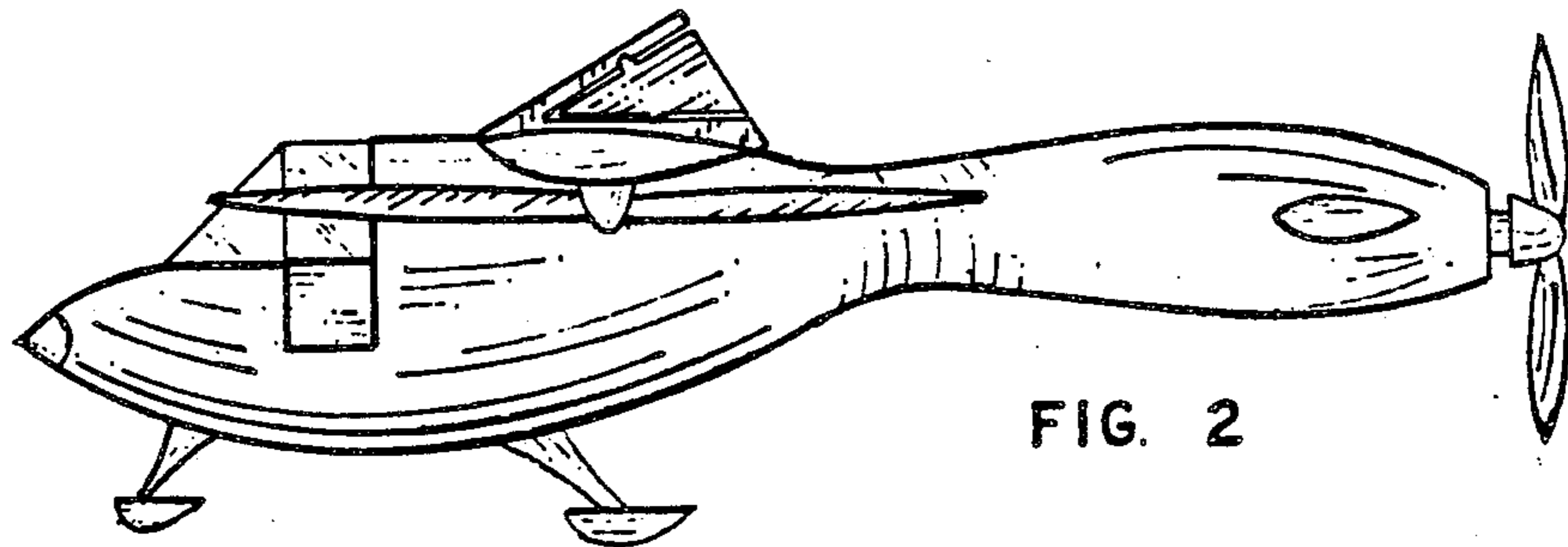

FIG. 2

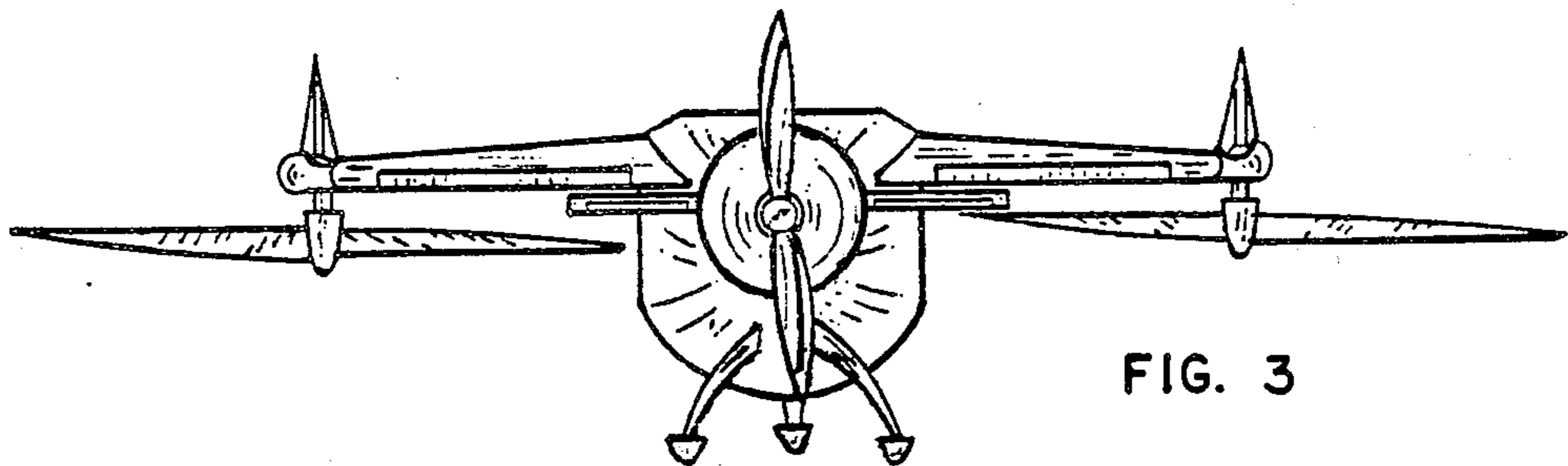

FIG. 3

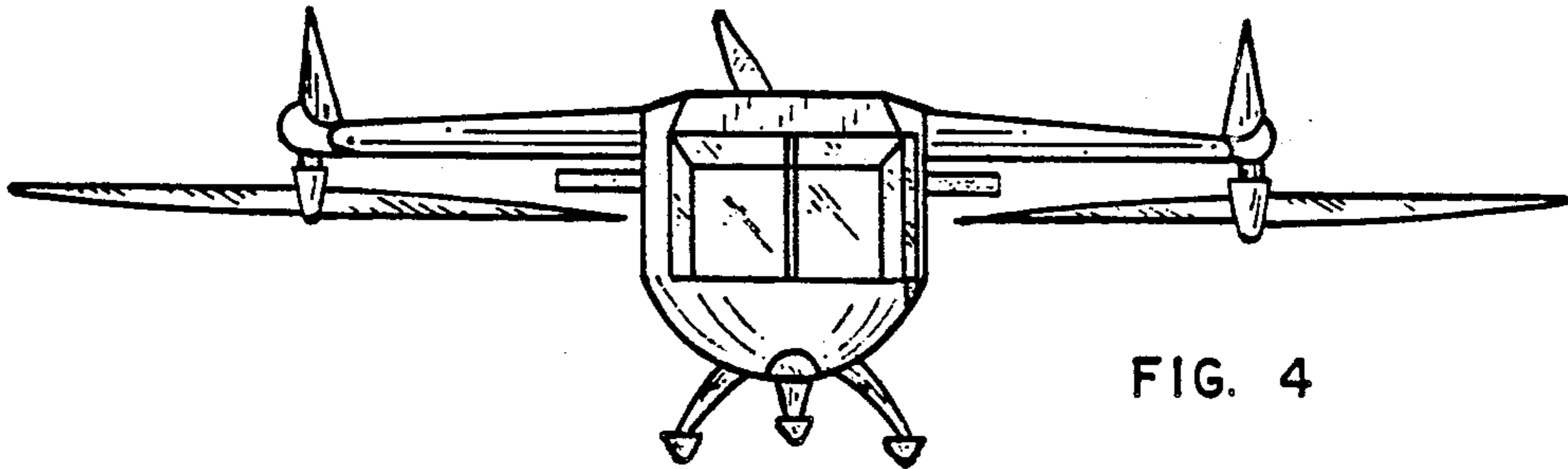

FIG. 4

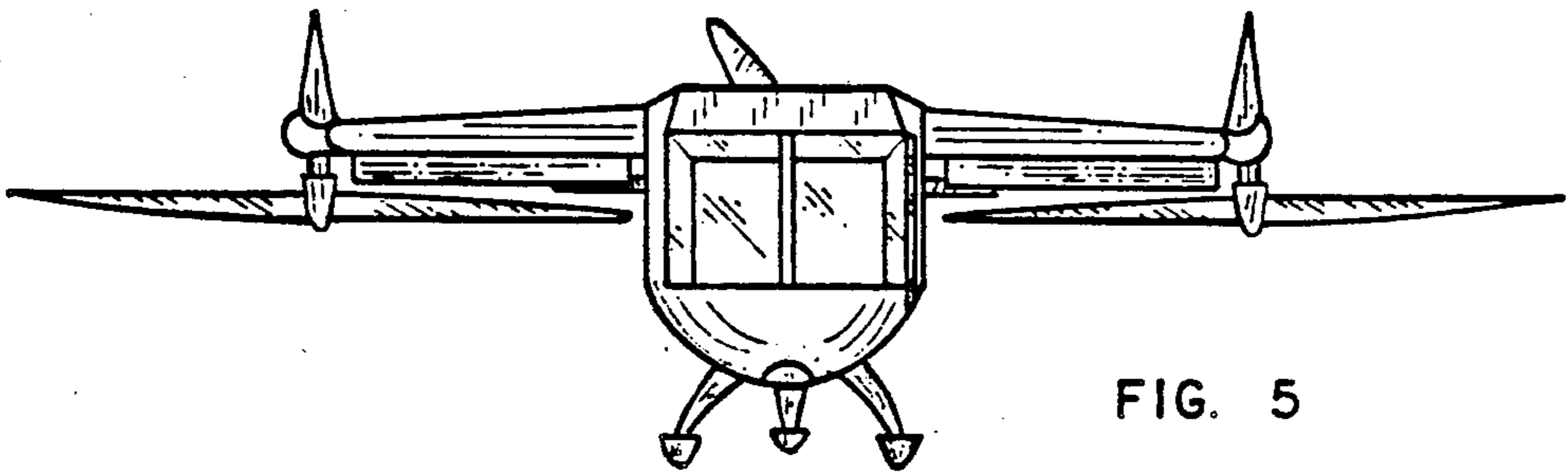

FIG. 5

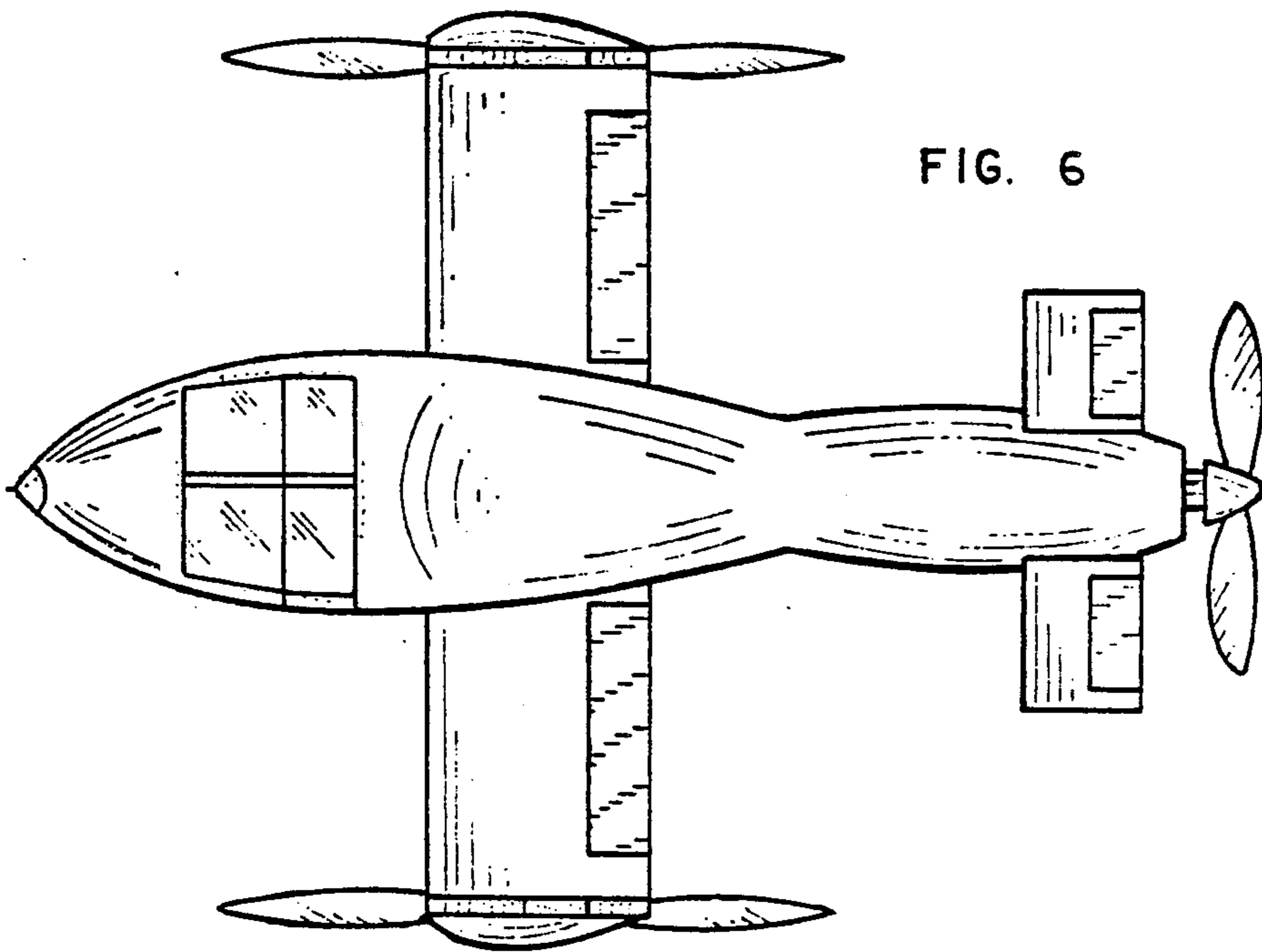

FIG. 6

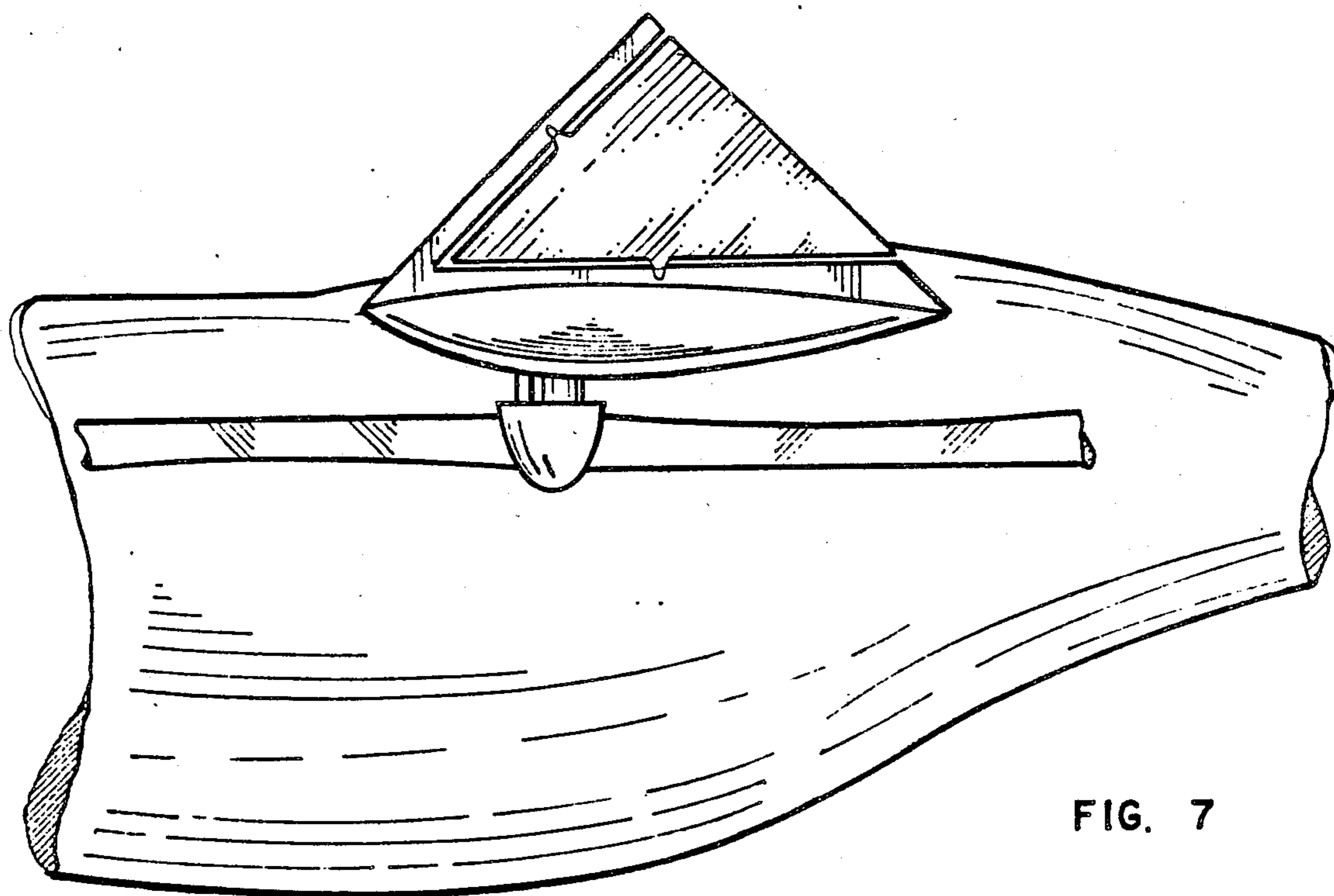

FIG. 7

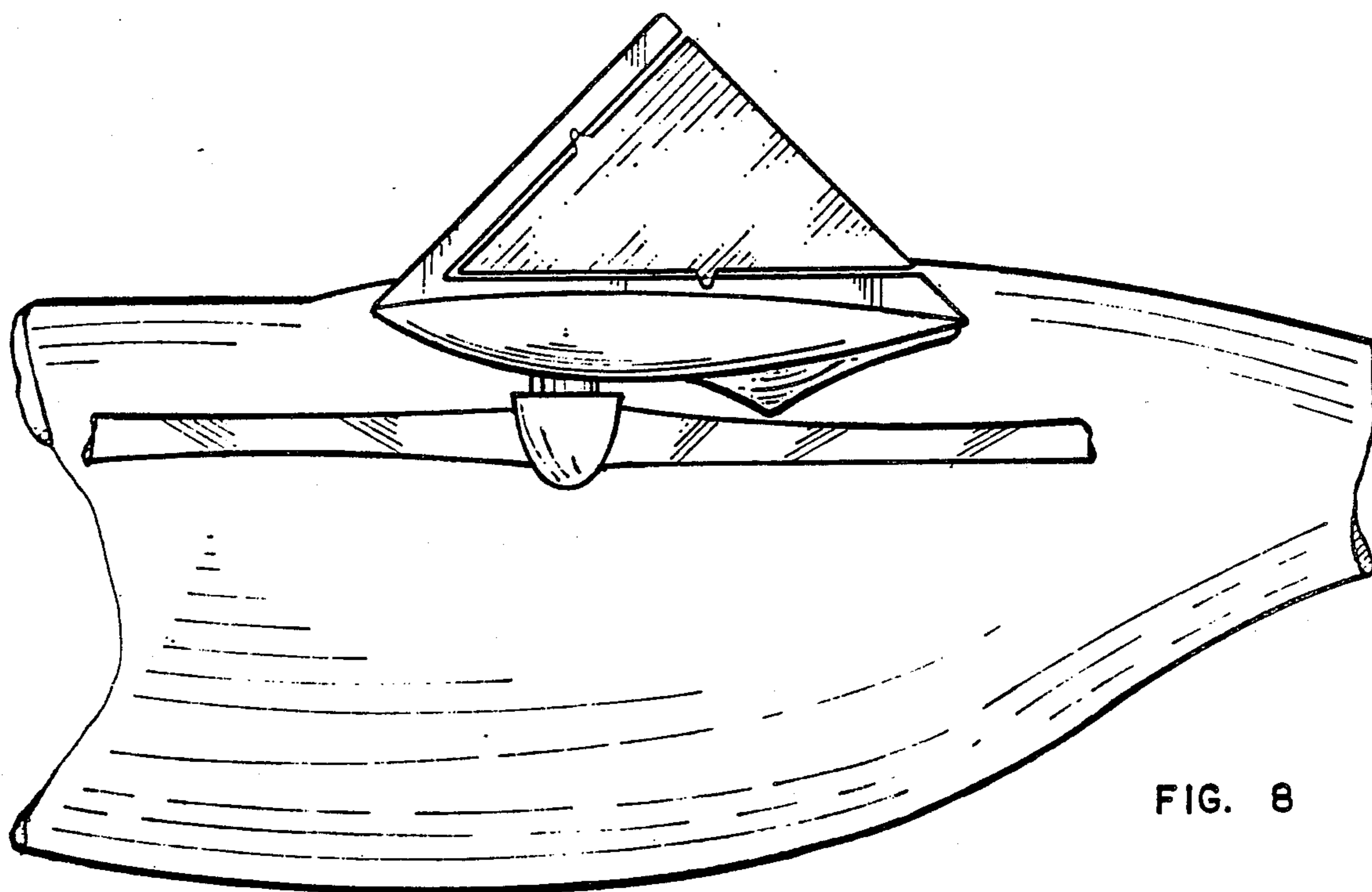

FIG. 8

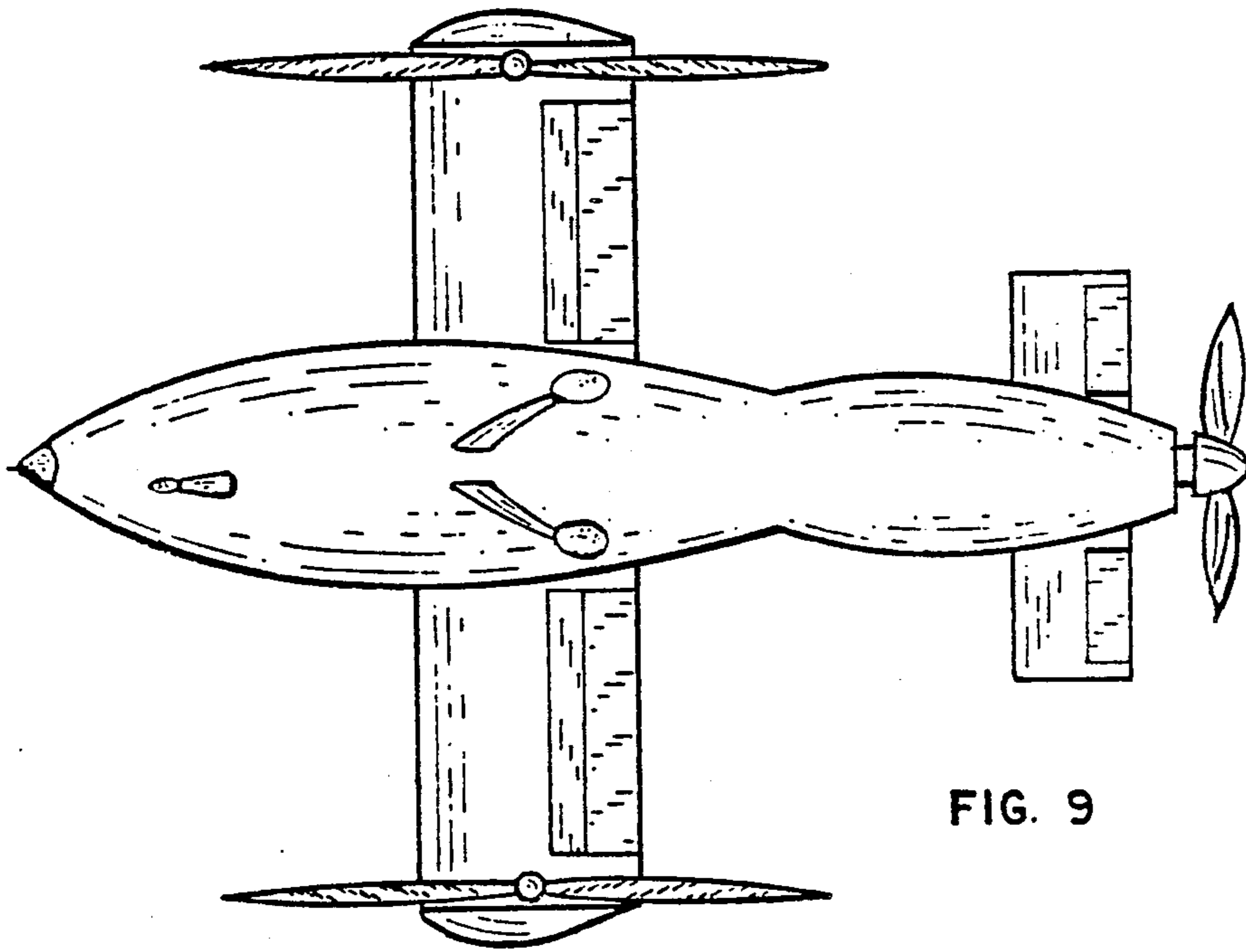

FIG. 9