

[54] VEHICLE BODY

[75] Inventors: Gary N. Clark, Taylor; Kirk H. Jones, Troy; Edward T. Welburn, Jr., Detroit, all of Mich.

[73] Assignee: General Motors Corporation, Detroit, Mich.

[**] Term: 14 Years

[21] Appl. No.: 776,129

[22] Filed: Sep. 13, 1985

[52] U.S. Cl. D12/90

[58] Field of Search D12/90-91,
D12/88; 296/1.5, 185

[56] References Cited
PUBLICATIONS

Motor Trend, 9/83, p. 80, Jaguar V-12, Prototype Coupe, center of page.
Road & Track, 10/84, p. 160, 1968 Porsche 908 Coupe, center right side of page.

Primary Examiner—James M. Gandy
Attorney, Agent, or Firm—Herbert Furman

[57] CLAIM

The ornamental design for a vehicle body, as shown and described.

DESCRIPTION

FIG. 1 is a side elevational view of a vehicle body showing our new design.

FIG. 2 is a top plan view.

FIG. 3 is a rear elevational view.

FIG. 4 is a front elevational view.

FIG. 5 is a front top perspective view, and

FIG. 6 is a rear quarter perspective view.

The broken lines in the drawing are for illustrative purposes only and form no part of the design claimed.

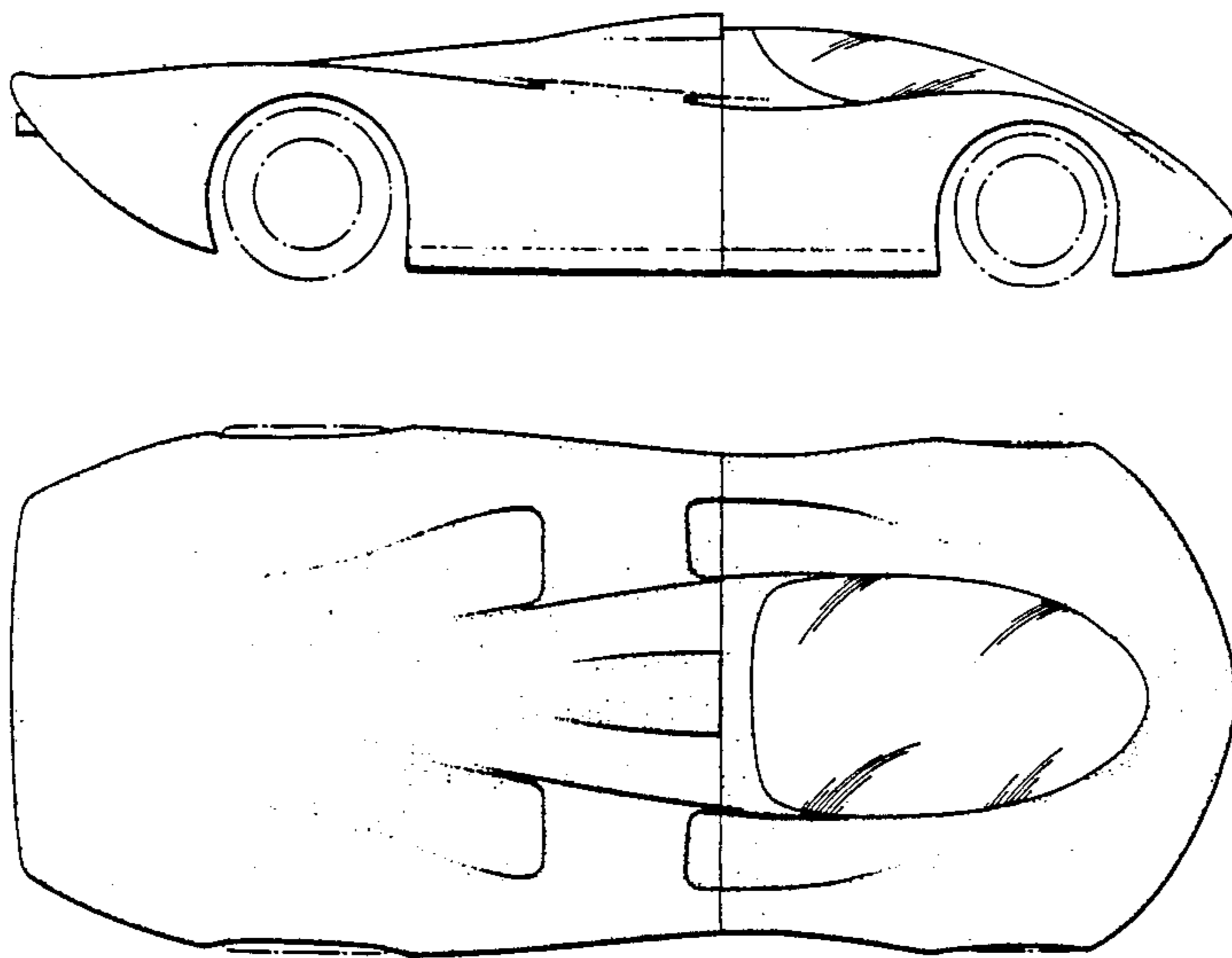

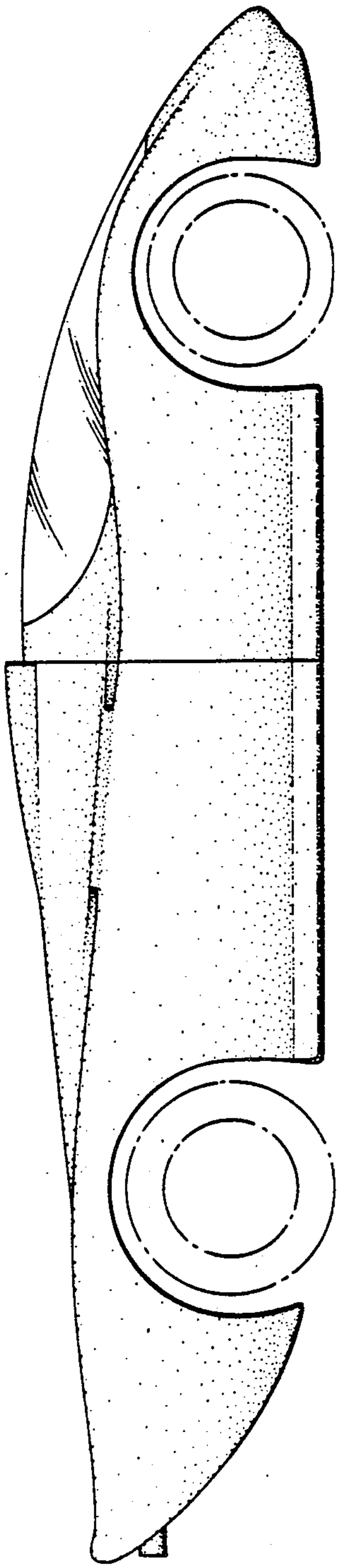

Fig. 1

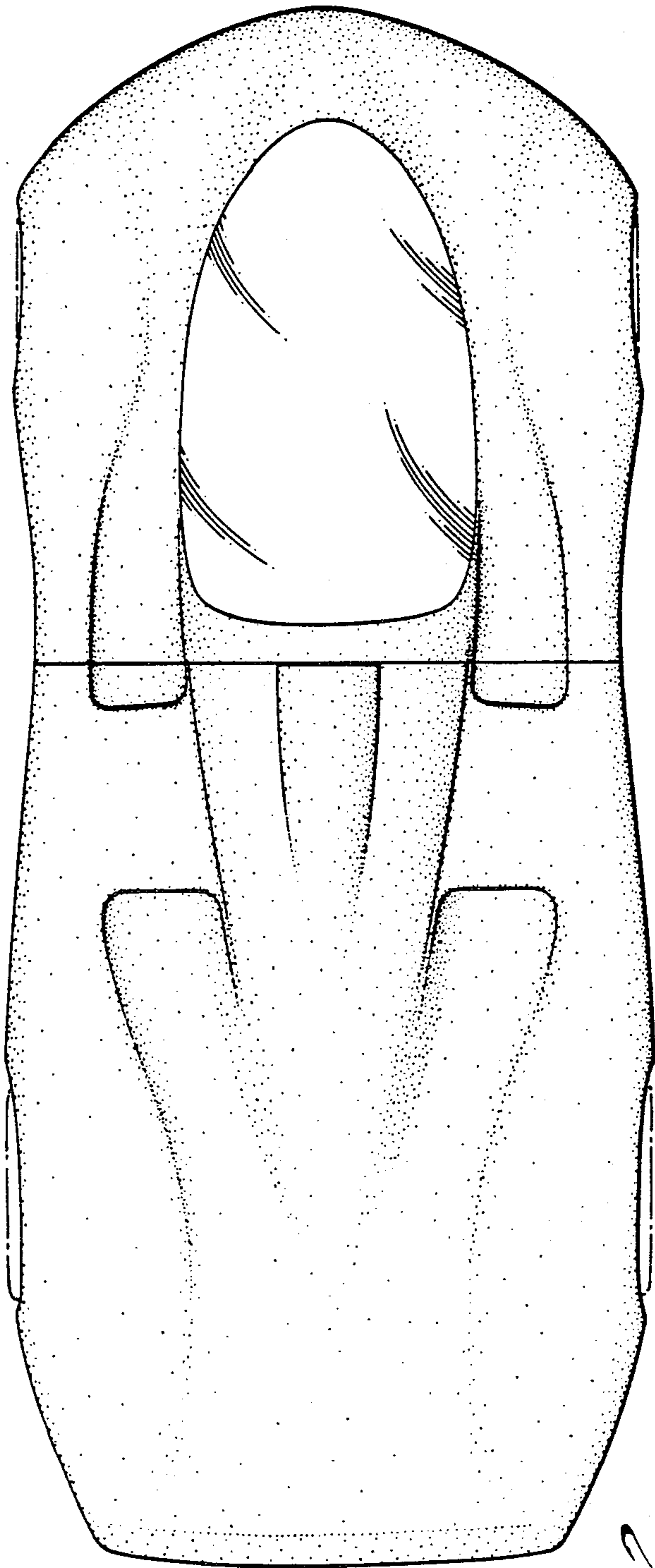

Fig. 2

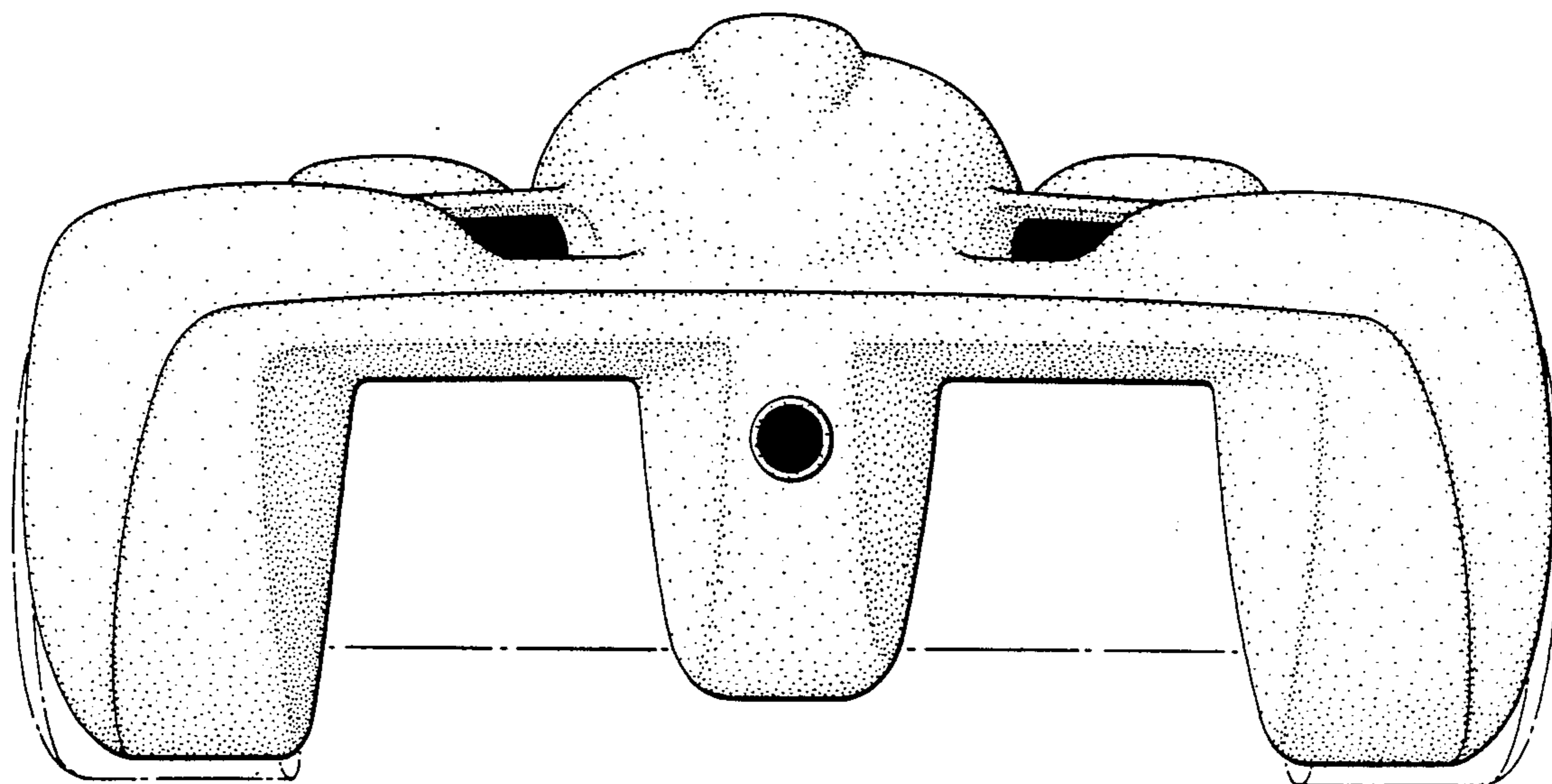

Fig. 3

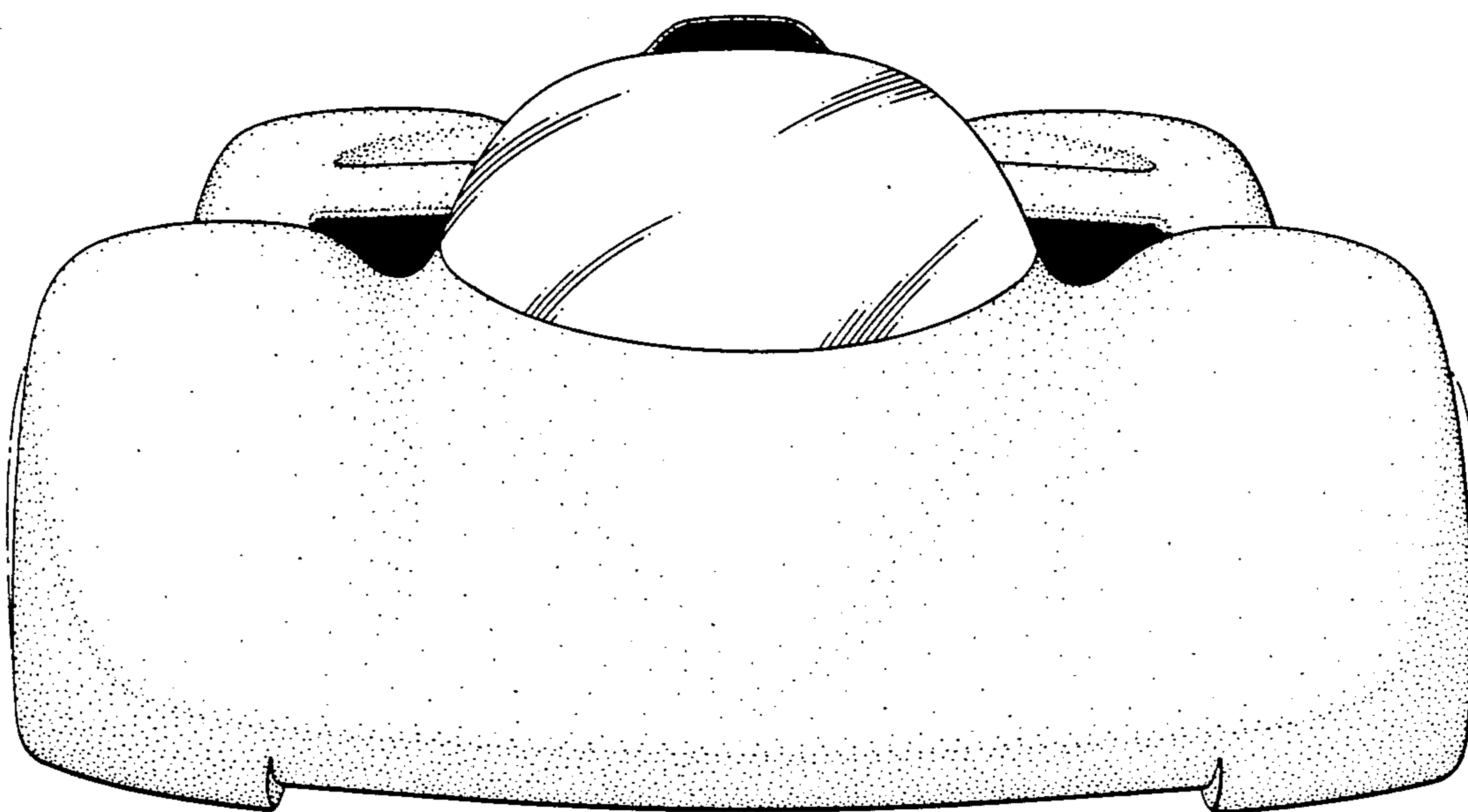

Fig. 4

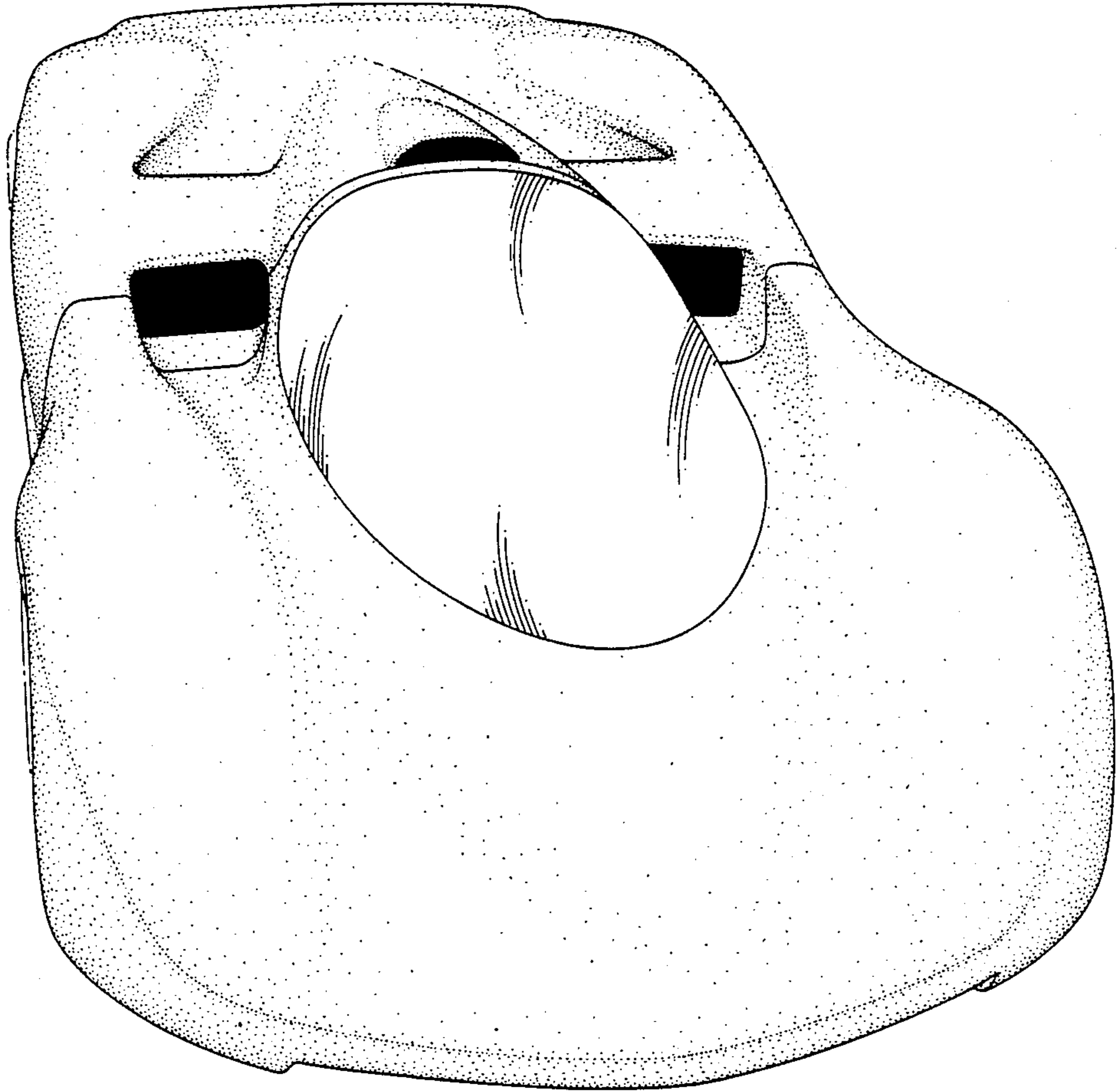

Fig. 5

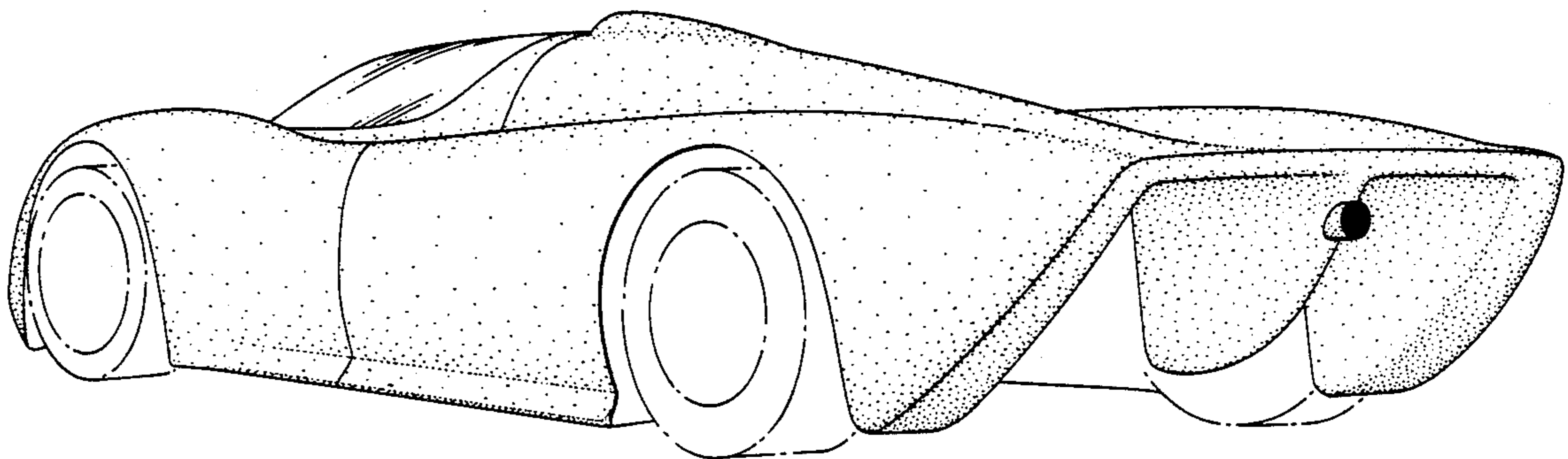

Fig. 6