

[54] COMBINED SPARE TIRE AND TRAILER  
HITCH FOR STANDARD RECEIVER BARS

[76] Inventor: Roland A. Smith, 2483 American  
Ave., Hayward, Calif. 94545

[\*\*] Term: 14 Years

[21] Appl. No.: 804,359

[22] Filed: Nov. 8, 1985

[52] U.S. Cl. .... D12/162; D12/202

[58] Field of Search ..... D12/162, 202;  
224/42.12, 42.15, 42.24; 280/511

[56] References Cited

U.S. PATENT DOCUMENTS

- D. 238,569 1/1976 Learn ..... D12/169
- D. 268,574 4/1983 Hampton ..... D12/162
- 3,730,556 5/1973 Aldape et al. .... 280/491 R

OTHER PUBLICATIONS

J. C. Whitney Catalog No. 451D, ©1984, p. 46, Front  
Tire Carriers, left side of page.

Primary Examiner—James M. Gandy  
Attorney, Agent, or Firm—Linval B. Castle

[57] CLAIM

The ornamental design of a combined spare tire and  
trailer hitch for standard receiver bars, as shown and  
described.

DESCRIPTION

FIG. 1 is a side elevational view of a combined spare  
tire and trailer hitch for standard receiver bars, showing  
my new design it being understood that the broken line  
illustration of a mounted spare tire and a typical re-  
ceiver bar are for illustrative purposes only and form no  
part of the claimed design;

FIG. 2 is the opposite side elevational view thereof;

FIG. 3 is a rear end elevational view thereof;

FIG. 4 is a front end elevational view thereof;

FIG. 5 is a top plan view thereof;

FIG. 6 is a bottom plan view thereof;

FIG. 7 is a perspective view thereof;

FIG. 8 is a side elevational view illustrating either side  
of a second embodiment of a combined spare tire and  
trailer hitch for standard receiver bars for supporting  
two spare tires;

FIG. 9 is a rear end elevational view of FIG. 8;

FIG. 10 is a front end elevational view of FIG. 8;

FIG. 11 is a top plan view of FIG. 8; and

FIG. 12 is a bottom plan view of FIG. 8.

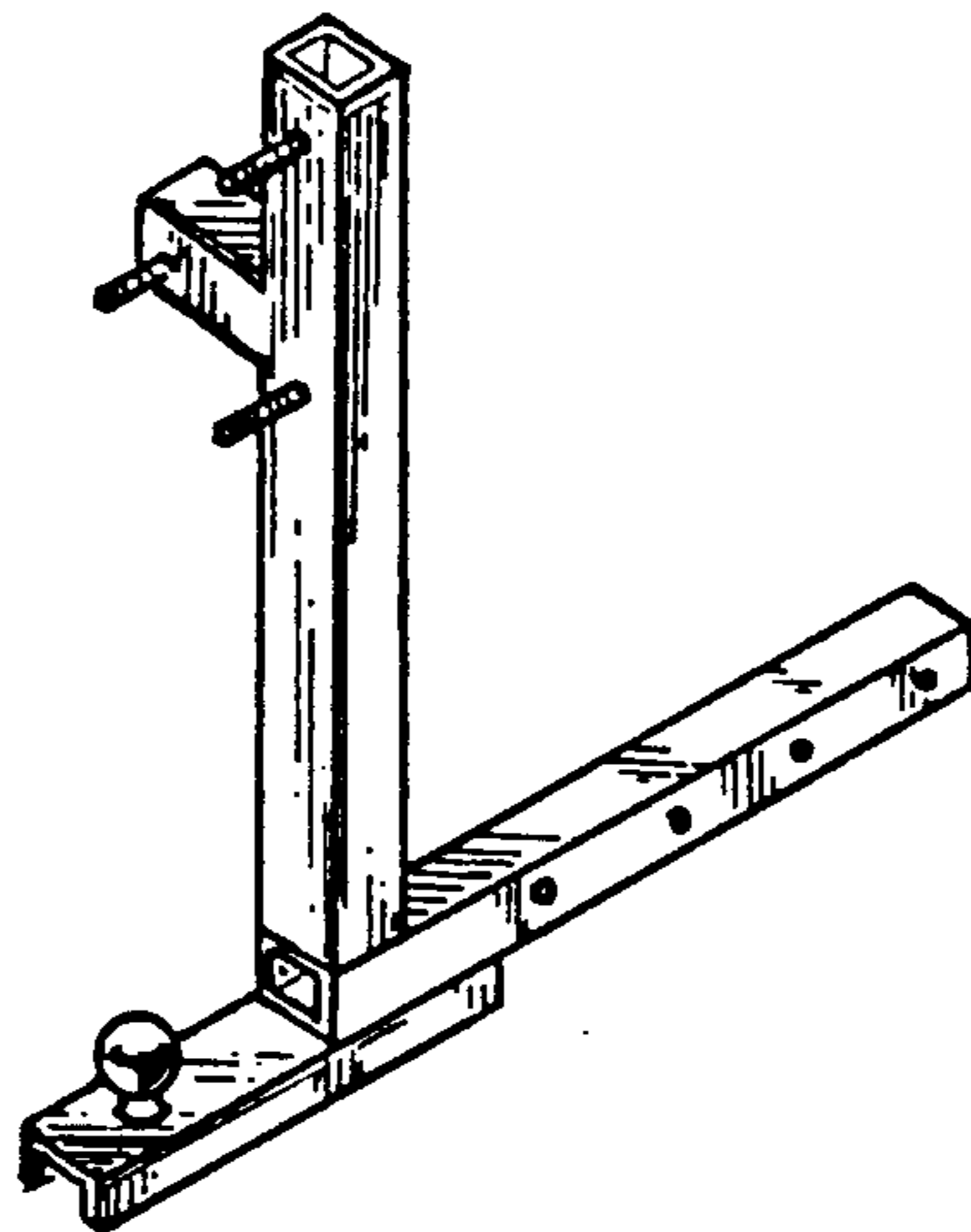

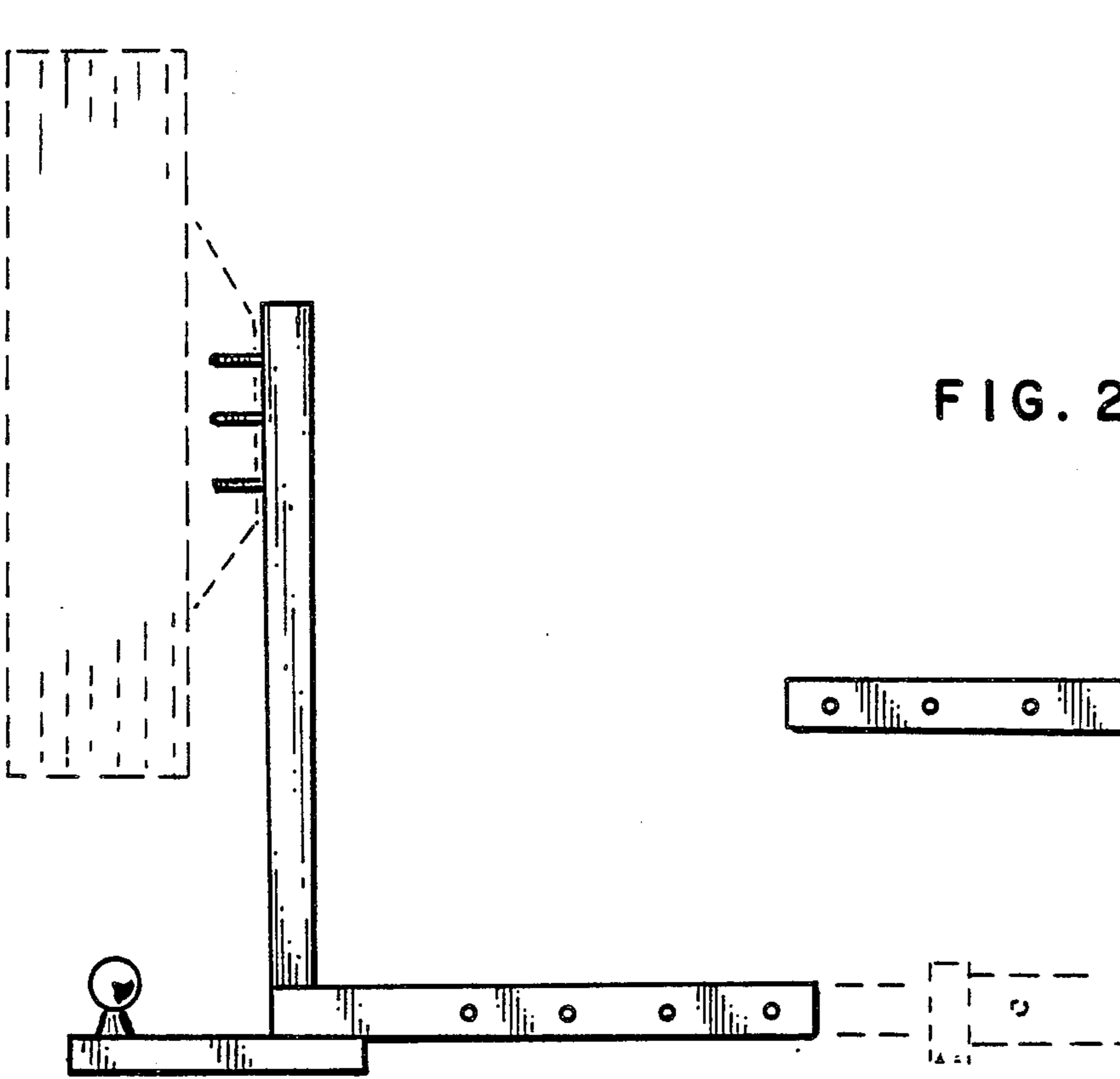

FIG. 1

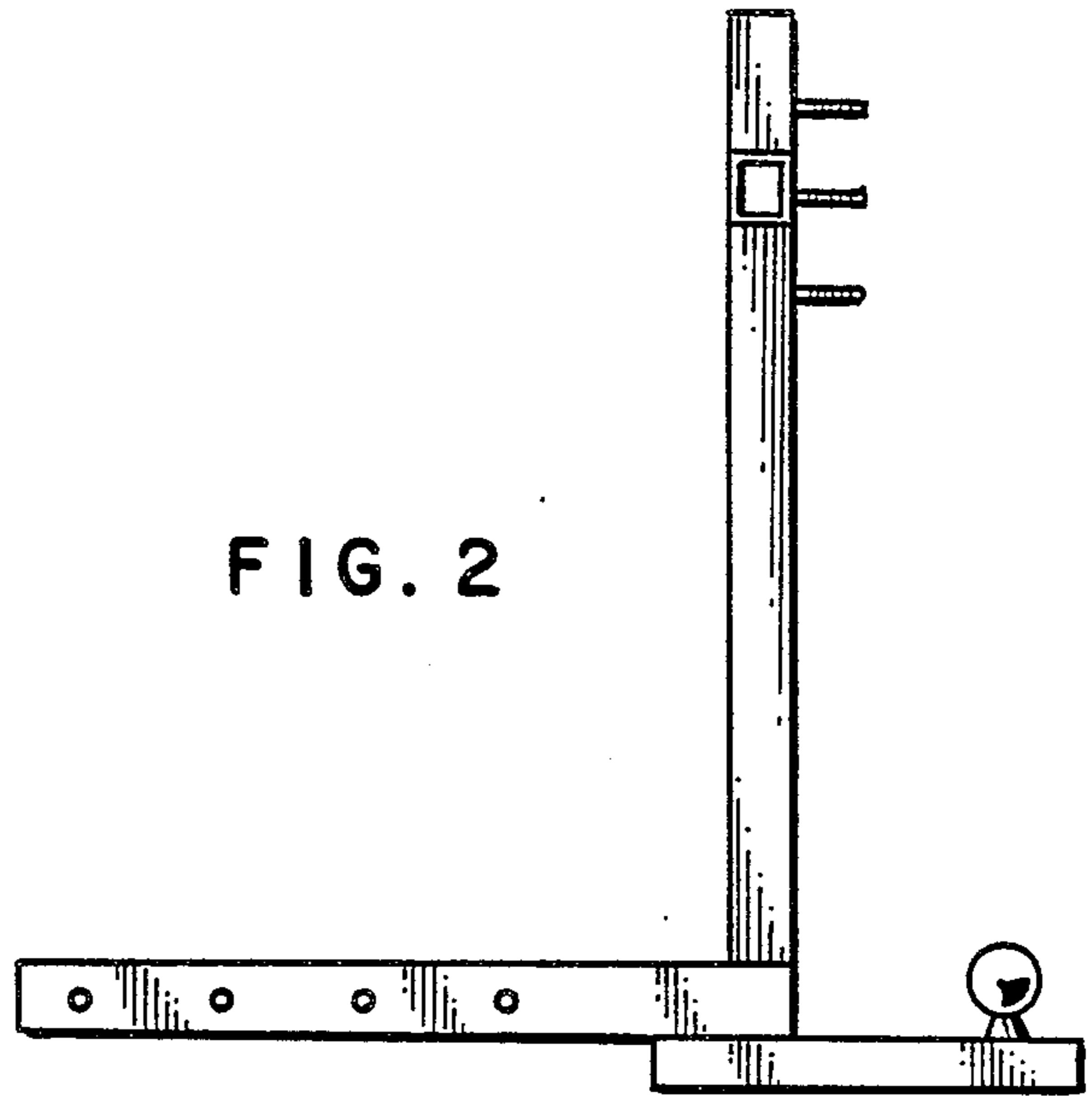

FIG. 2

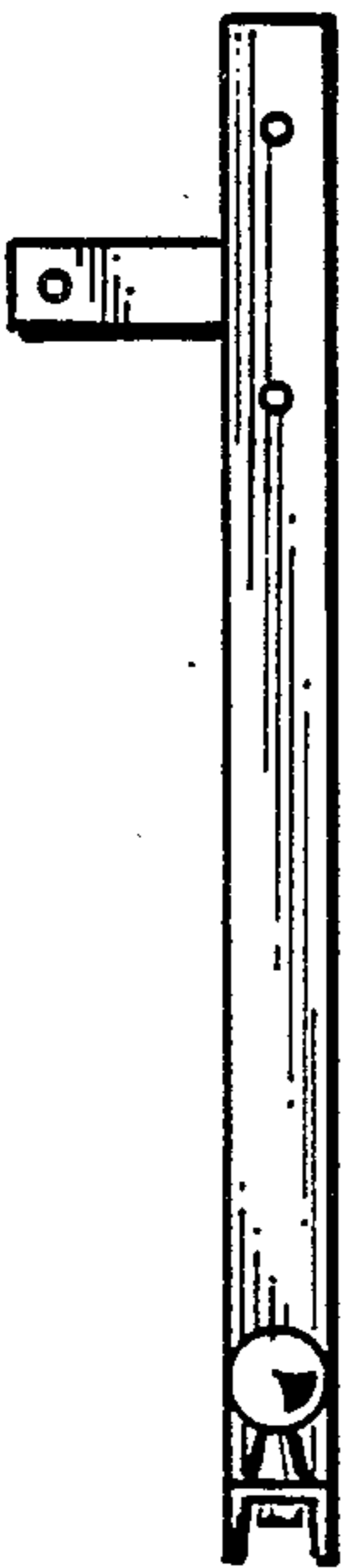

FIG. 3

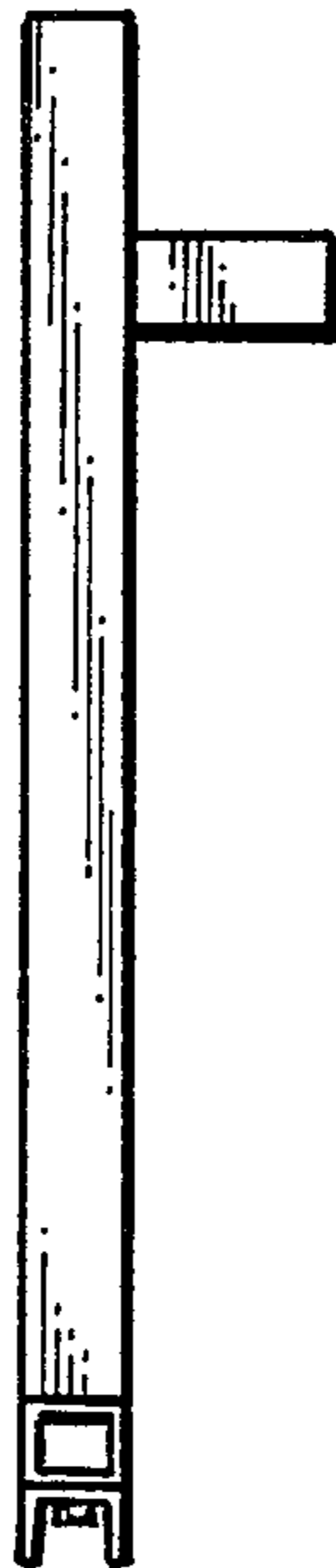

FIG. 4

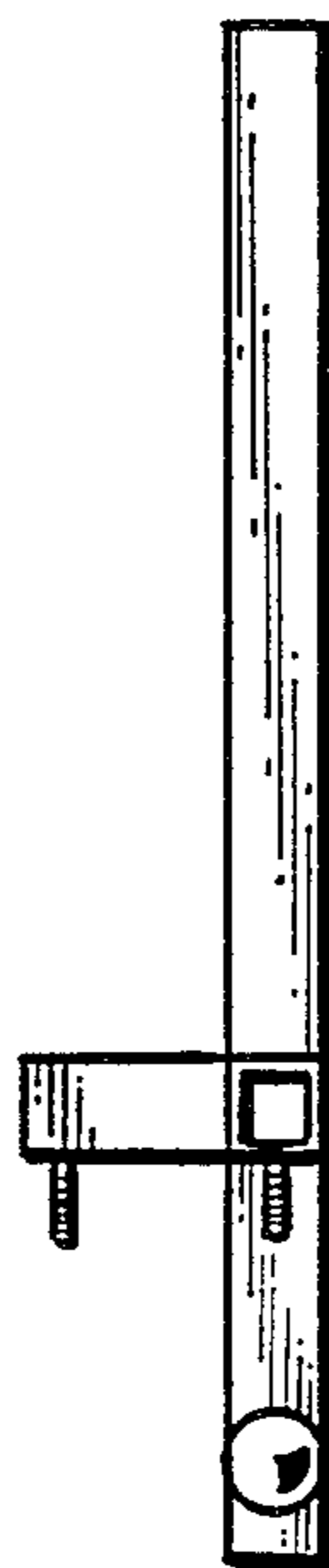

FIG. 5



FIG. 6

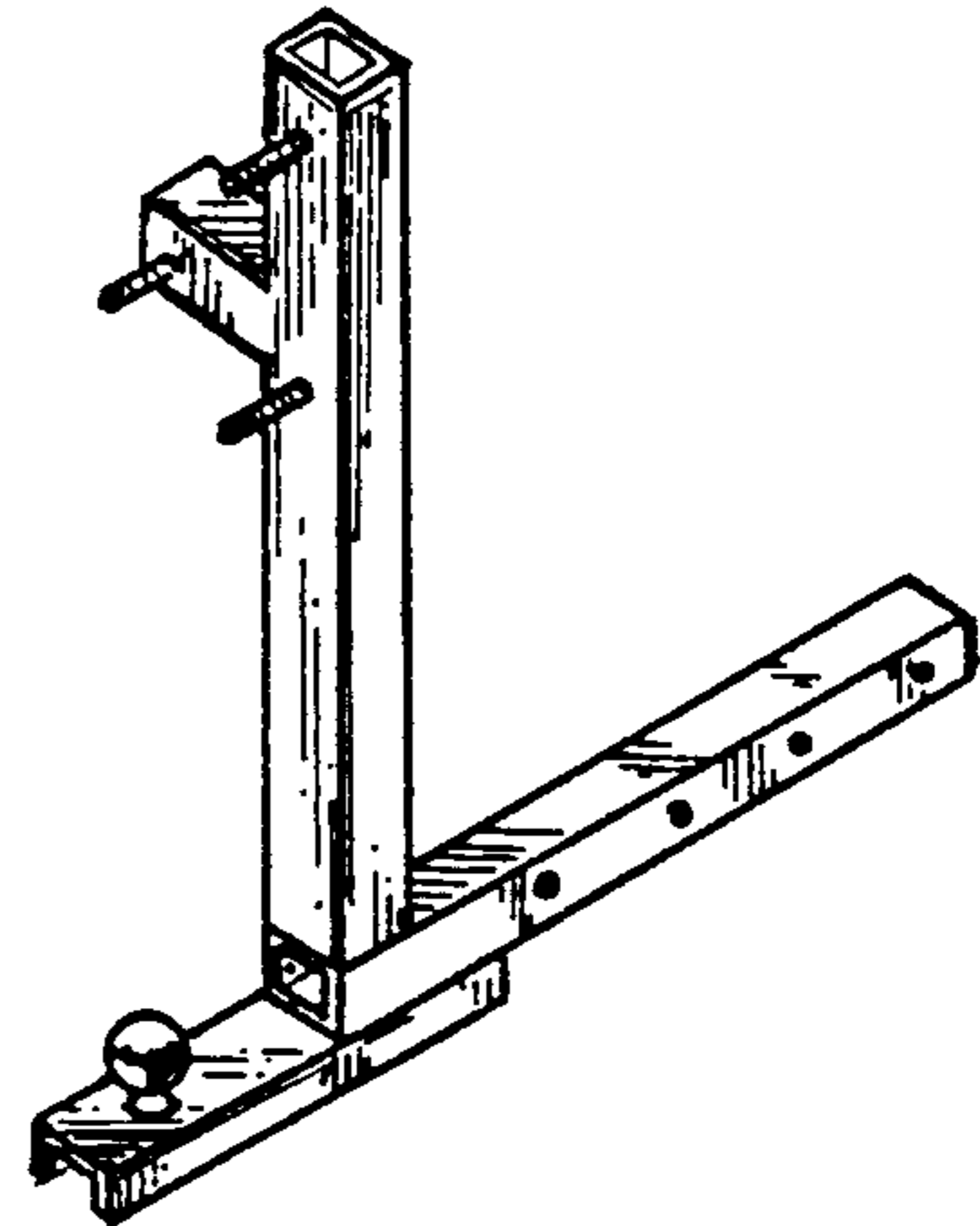

FIG. 7

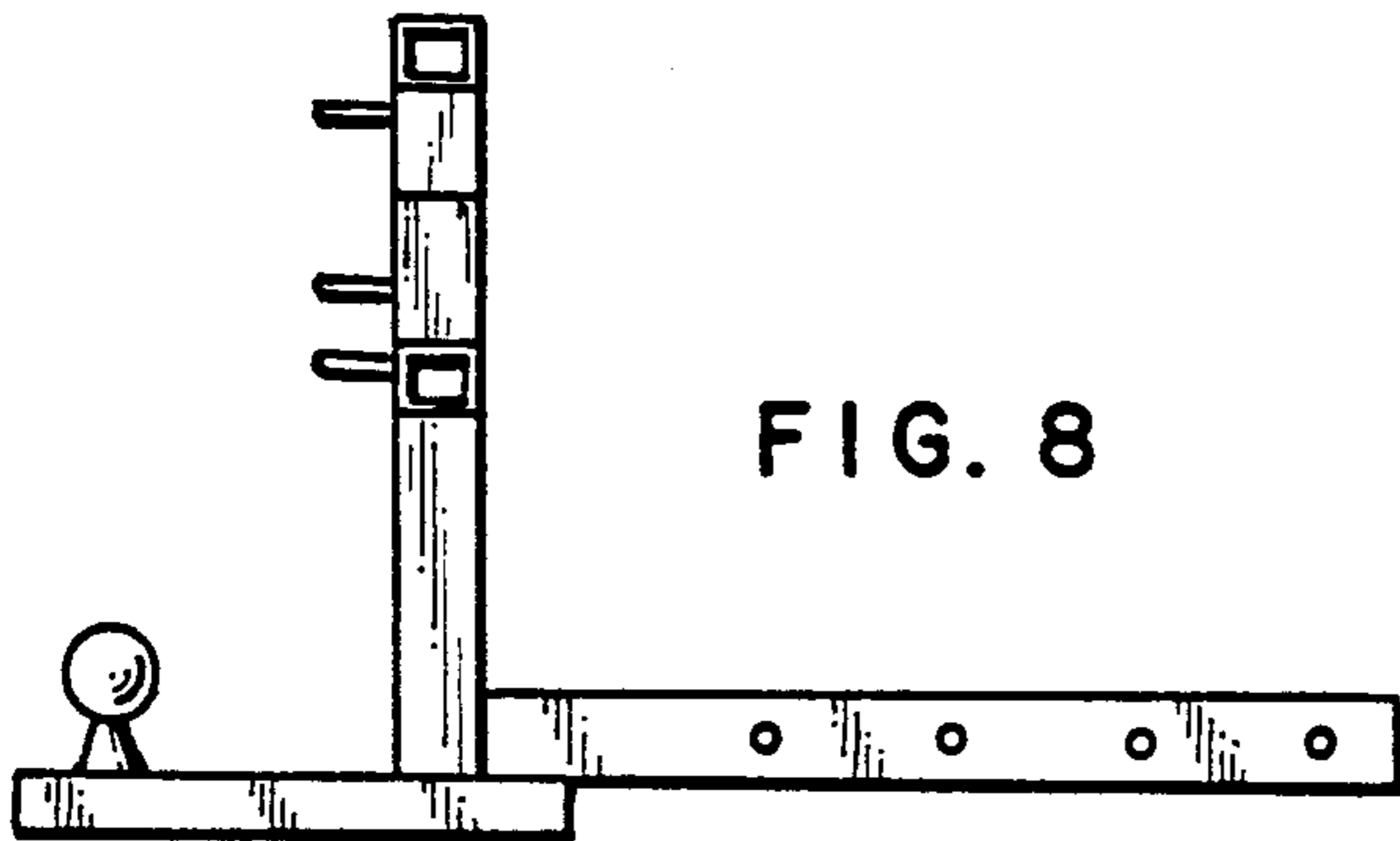

FIG. 8

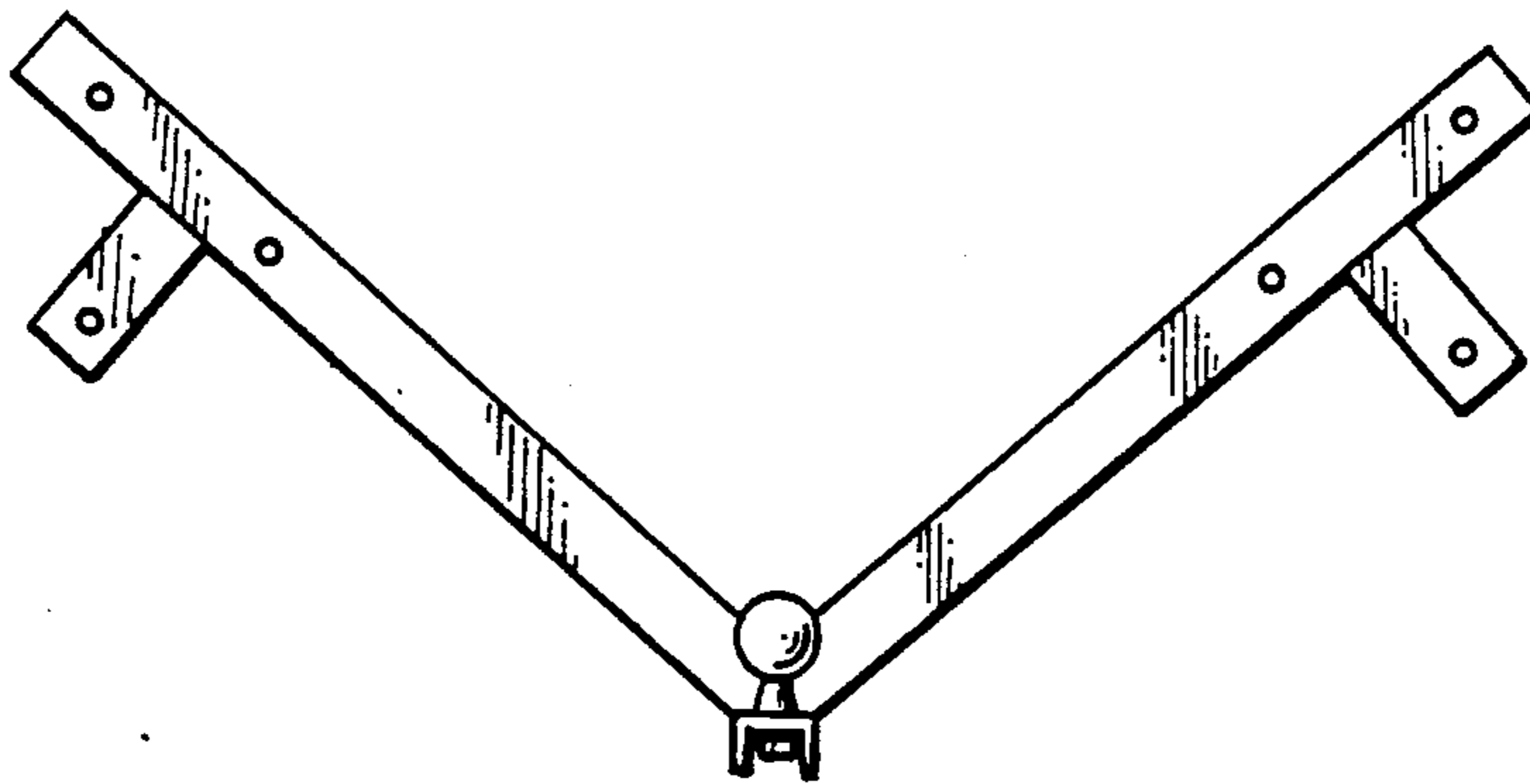

FIG. 9

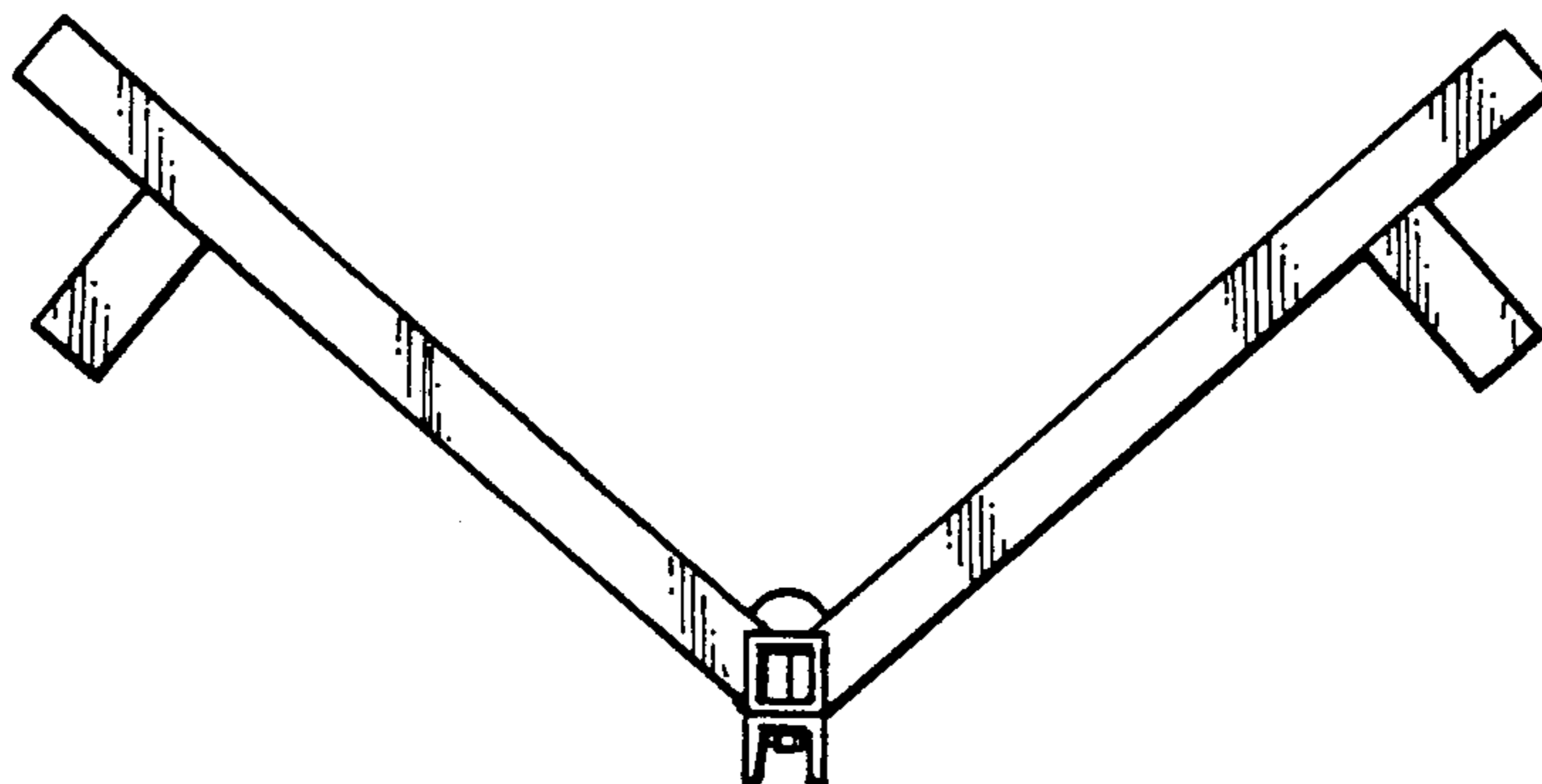

FIG. 10

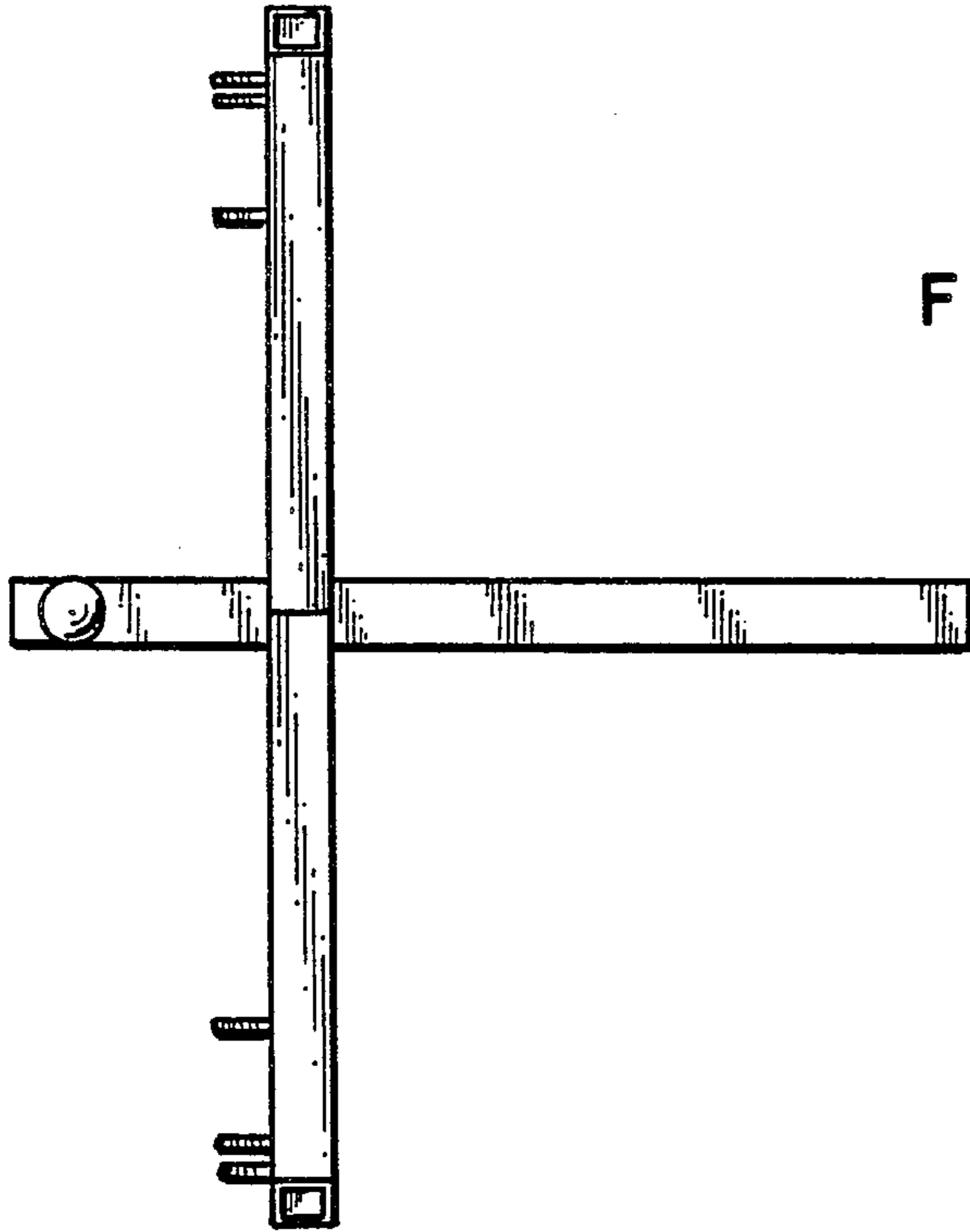

FIG. 11

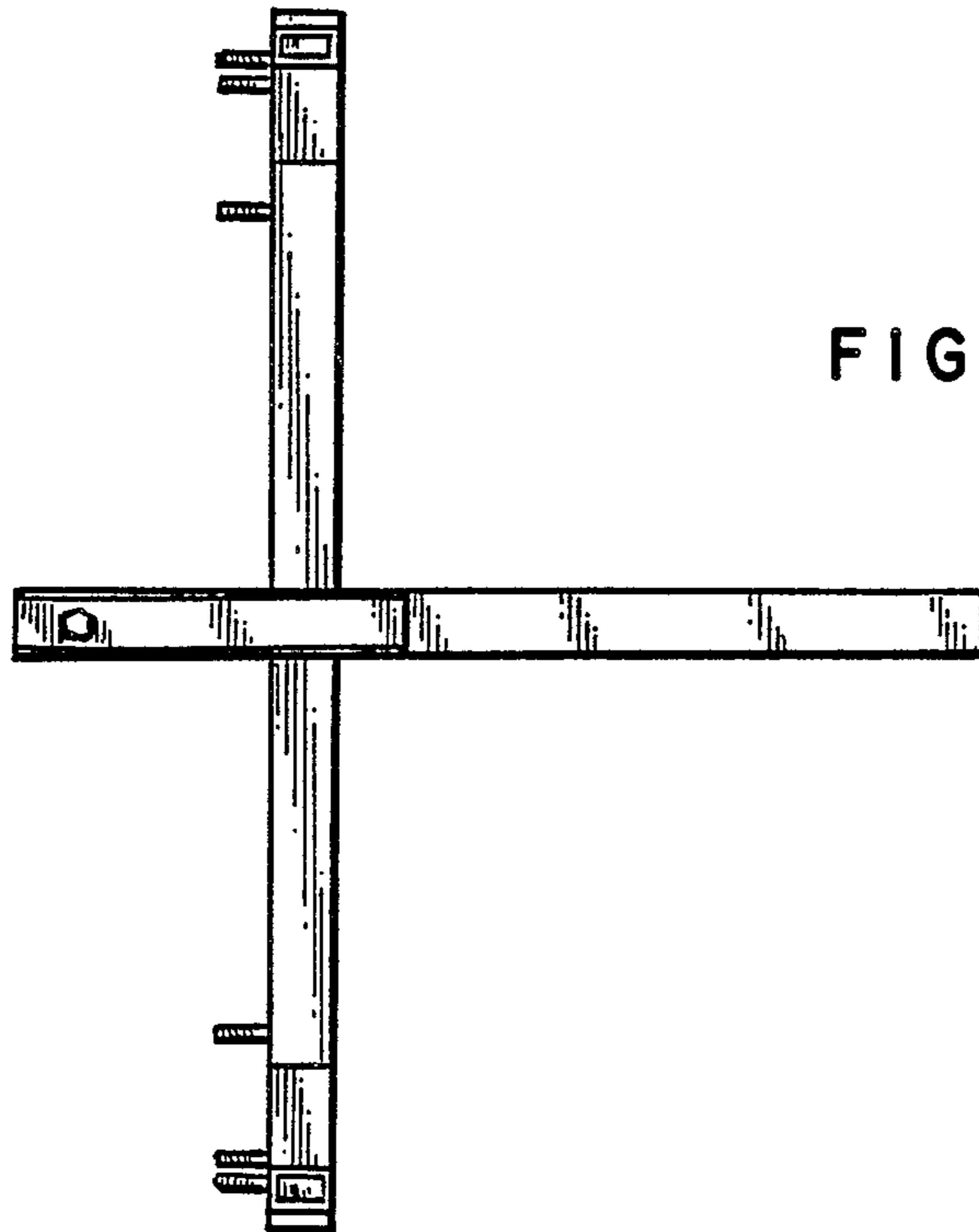

FIG. 12