

United States Patent [19]

Wedel

[11] Patent Number: Des. 293,148

[45] Date of Patent: ** Dec. 8, 1987

[54] CART

[75] Inventor: Hans Wedel, Menden, Fed. Rep. of Germany

[73] Assignee: Cramer GmbH & Co KG, Menden, Fed. Rep. of Germany

[**] Term: 14 Years

[21] Appl. No.: 702,372

[22] Filed: Feb. 15, 1985

[30] Foreign Application Priority Data

Sep. 11, 1984 [DE] Fed. Rep. of Germany MR1023

[52] U.S. Cl. D34/21; D34/24; D6/477; D6/481; 280/47.19; 312/250

[58] Field of Search D34/21, 12, 22, 23, D34/24, 25, 26, 19, 20; D6/432, 436, 477, 481; 280/47.17, 47.19, 47.24, 47.26, 47.35; 312/250; 108/59

[56] References Cited

U.S. PATENT DOCUMENTS

D. 99,804	5/1936	Hoffmann	D34/24
D. 221,748	9/1971	Bloomfield et al.	D34/21
D. 252,563	8/1979	Vredenburg	D6/477
D. 288,331	2/1987	Huldt	D34/21
D. 288,859	3/1987	Huldt	D34/21
3,178,198	4/1965	Hamilton	280/47.35
3,698,735	10/1972	Bloomfield et al.	280/47.35
4,635,613	1/1987	Tucker et al.	D34/24

Primary Examiner—James M. Gandy

Assistant Examiner—Kay H. Chin

Attorney, Agent, or Firm—Collard, Roe & Galgano

[57] CLAIM

The ornamental design for a cart, substantially as shown.

DESCRIPTION

FIG. 1 is a perspective view of a cart showing my new design;

FIG. 2 is a right side elevational view thereof;

FIG. 3 is a top plan view thereof;

FIG. 4 is a left side elevational view thereof;

FIG. 5 is a rear elevational view thereof; and

FIG. 6 is a front elevational view thereof.

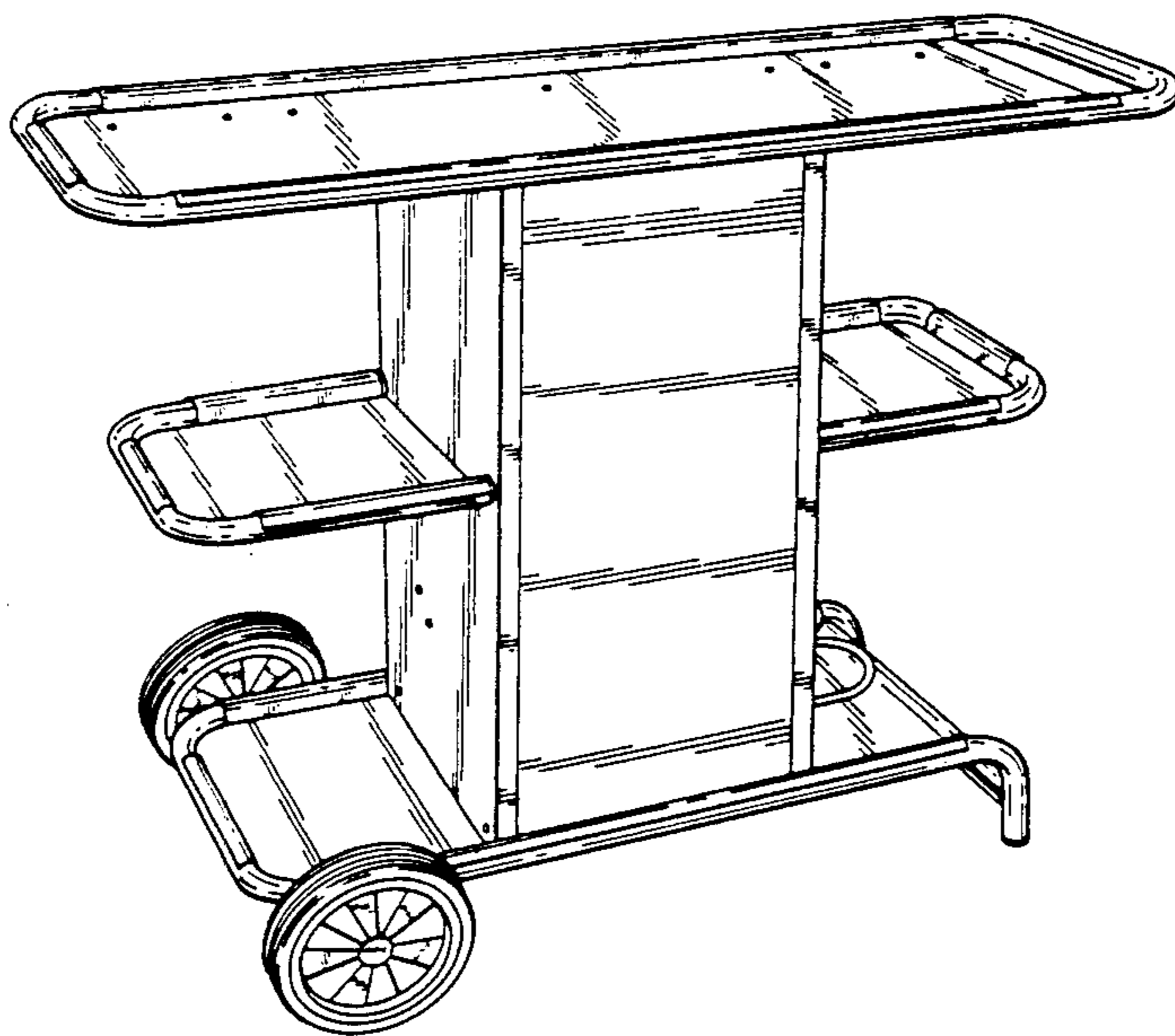

FIG. 1

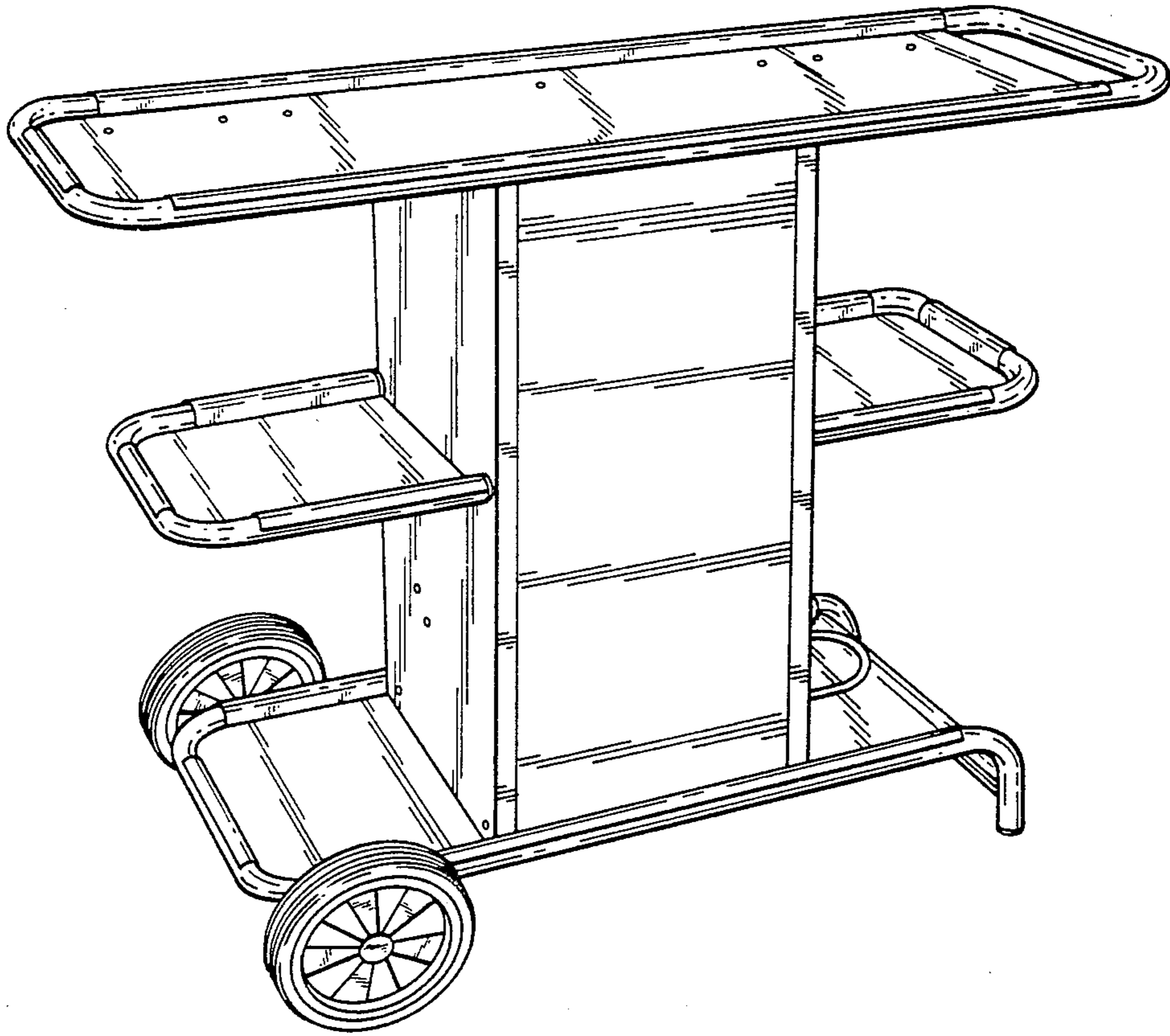
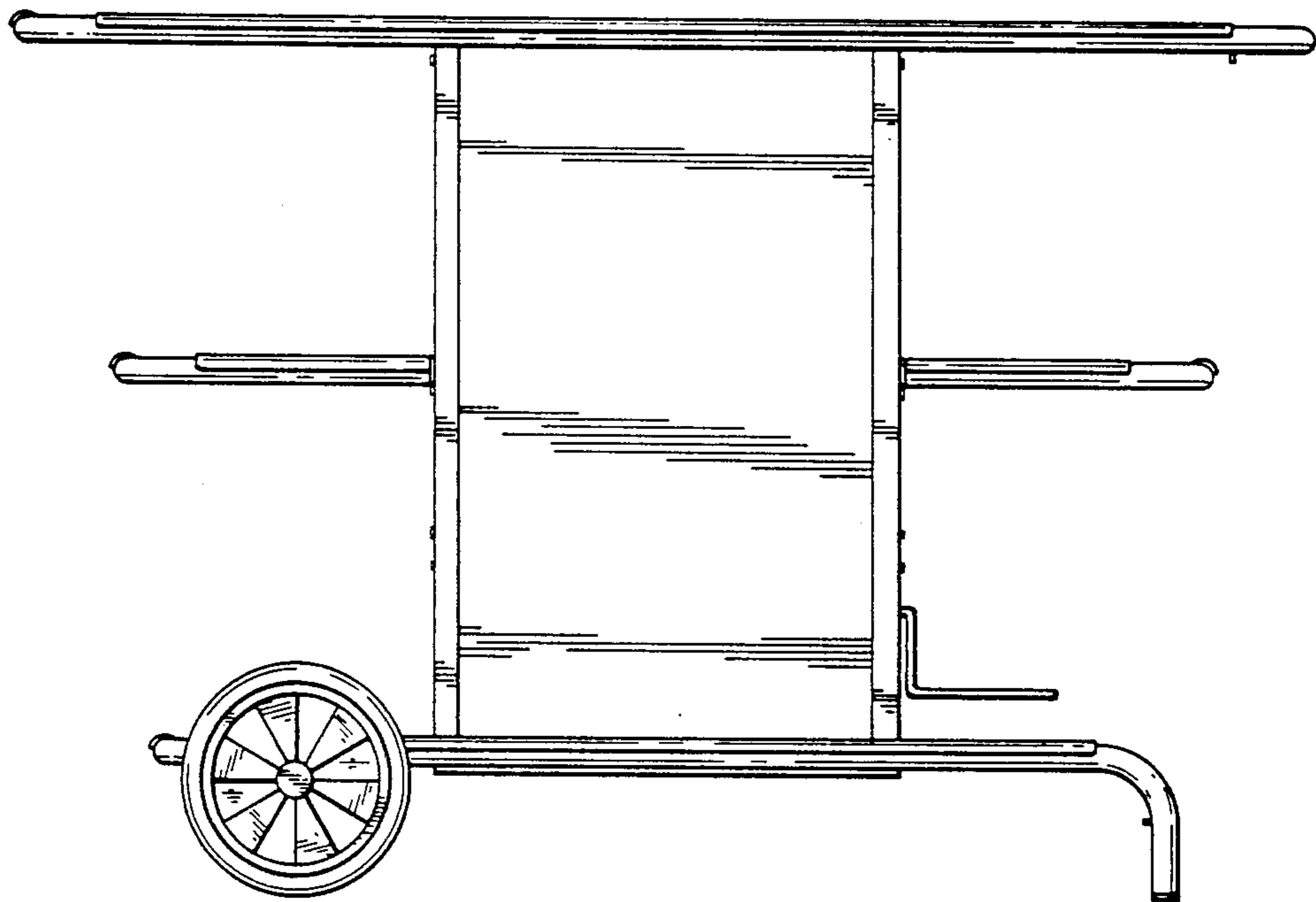

FIG. 2



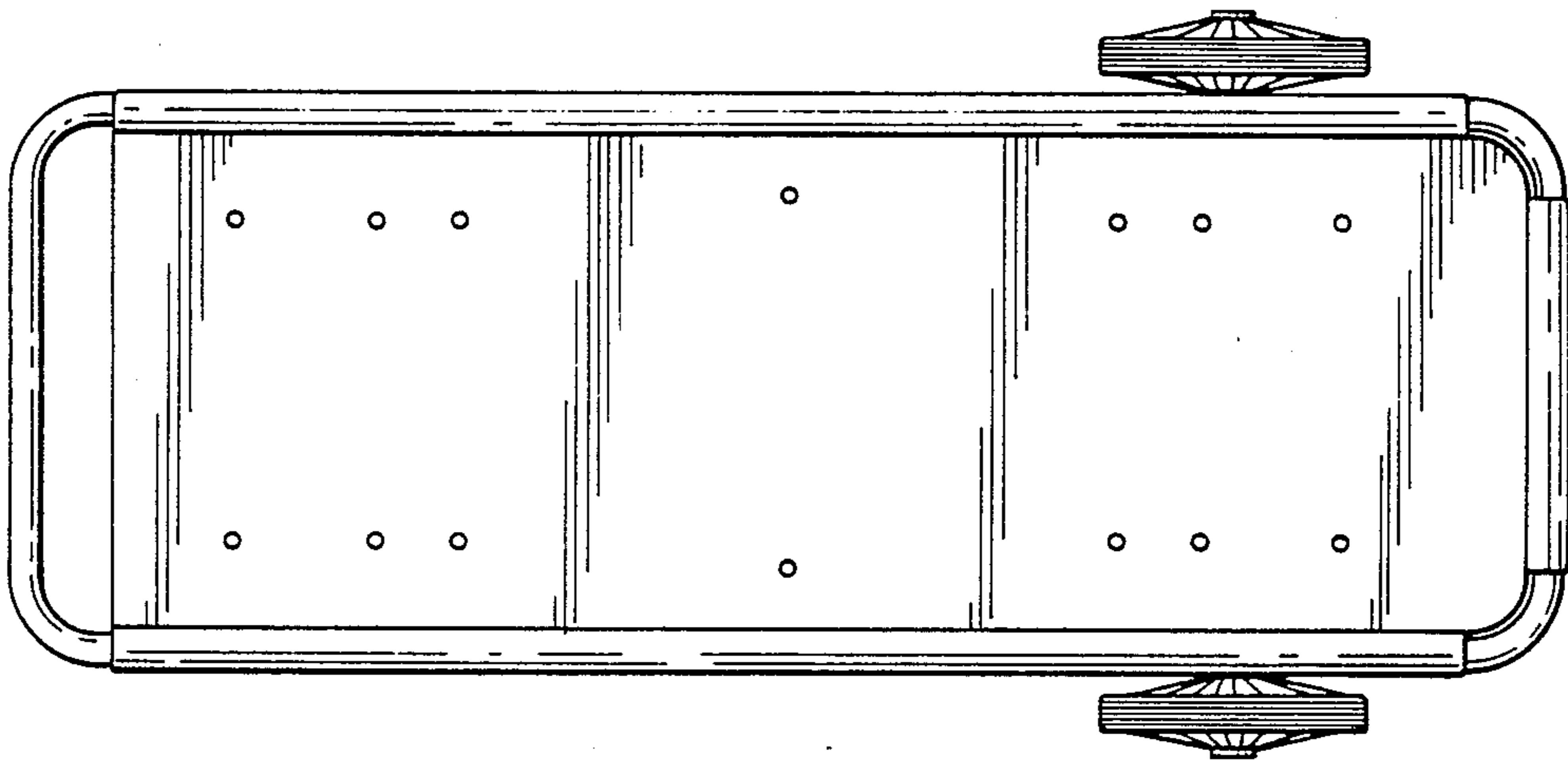

FIG. 3

FIG. 4

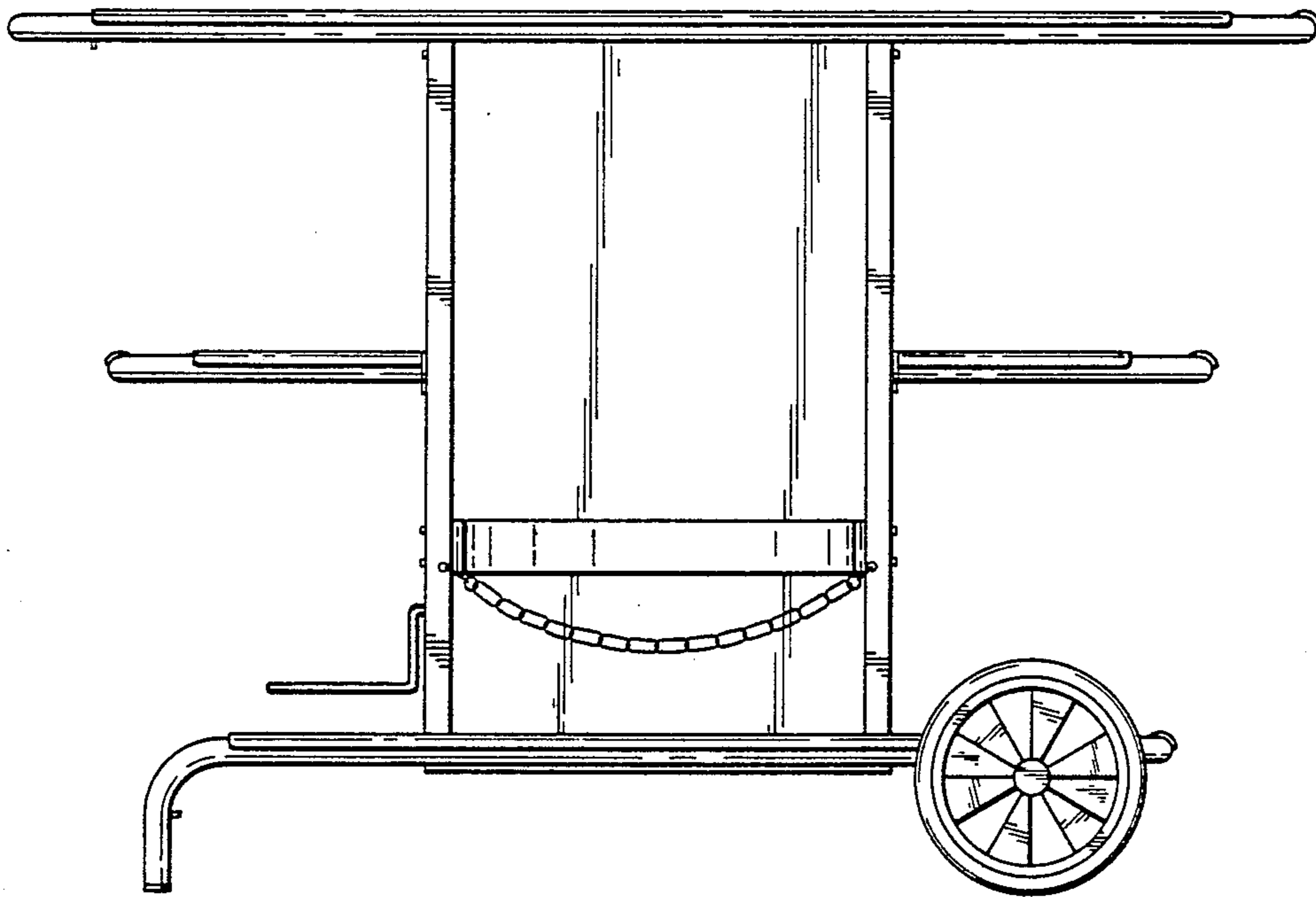

FIG. 5

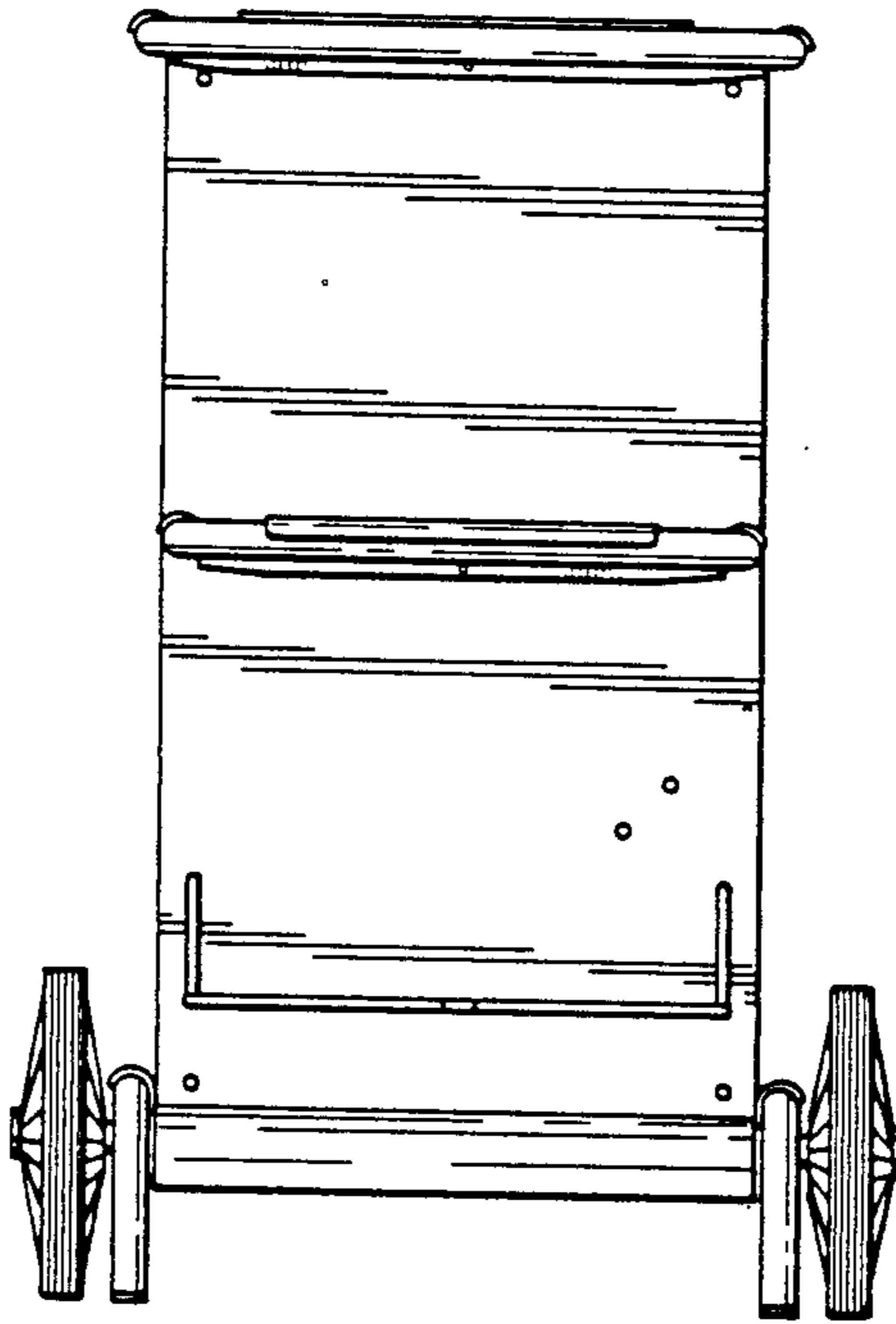

FIG. 6

