

United States Patent [19]
Brogdon

[11] **Patent Number: Des. 293,114**
[45] **Date of Patent: ** Dec. 8, 1987**

[54] **ENGINE**
[75] **Inventor: J. William Brogdon, Daphne, Ala.**
[73] **Assignee: Teledyne Industries, Inc., Los Angeles, Calif.**
[**] **Term: 14 Years**
[21] **Appl. No.: 906,649**
[22] **Filed: Sep. 11, 1986**

Related U.S. Application Data

[63] Continuation of Ser. No. 646,302, Aug. 31, 1984, abandoned.
[52] **U.S. Cl. D15/1**
[58] **Field of Search D15/1-9; 123/56 B, 56 BC, 56 BA, 41.66, 41.67, 41.7, 195 C, 198 E**

[56] **References Cited**

U.S. PATENT DOCUMENTS

D. 116,981 10/1939 Ohlsson et al. D15/3

D. 179,236 11/1956 Bernard D15/1
D. 224,169 7/1972 Rudd D15/1
D. 239,329 3/1976 Schramm D15/1
D. 277,485 2/1985 Iwakura et al. D15/3
D. 277,756 2/1985 Davidson D15/3
3,242,913 3/1966 Fiedler 123/41.67
4,429,668 2/1984 Nakagawa et al. 123/56 BA

Primary Examiner—Wallace R. Burke
Assistant Examiner—Brian N. Vinson
Attorney, Agent, or Firm—Gifford, Groh, VanOphem, Sheridan, Sprinkle and Dolgorukov

[57] **CLAIM**

The ornamental design for an engine, as shown.

DESCRIPTION

FIG. 1 is a top, front perspective view of an engine showing my new design;
FIG. 2 is a right side elevational view thereof;
FIG. 3 is a front and left side perspective view thereof;
FIG. 4 is a rear and right side perspective view thereof;
FIG. 5 is a rear and left side perspective view thereof;
and
FIG. 6 is a rear elevational view thereof.

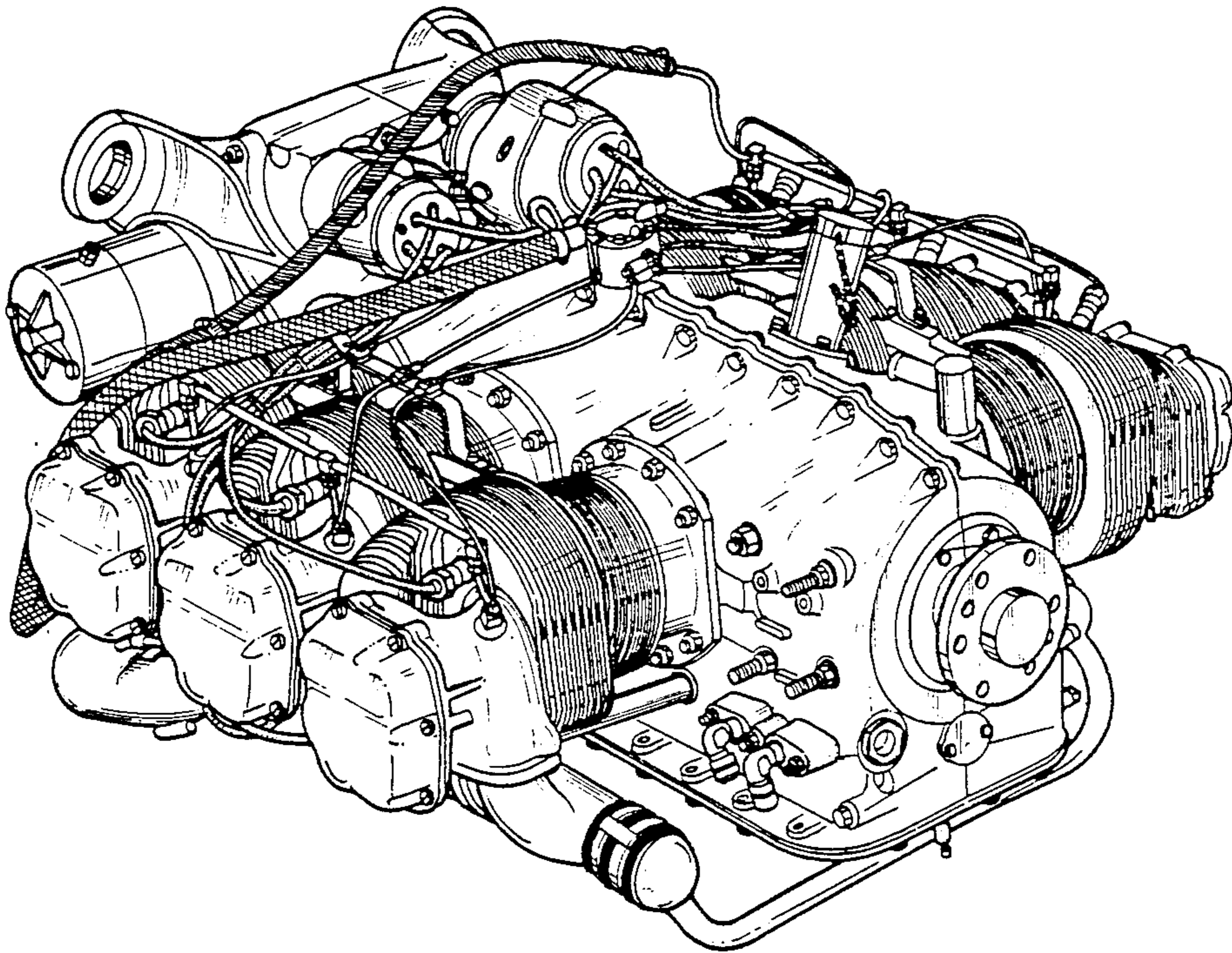

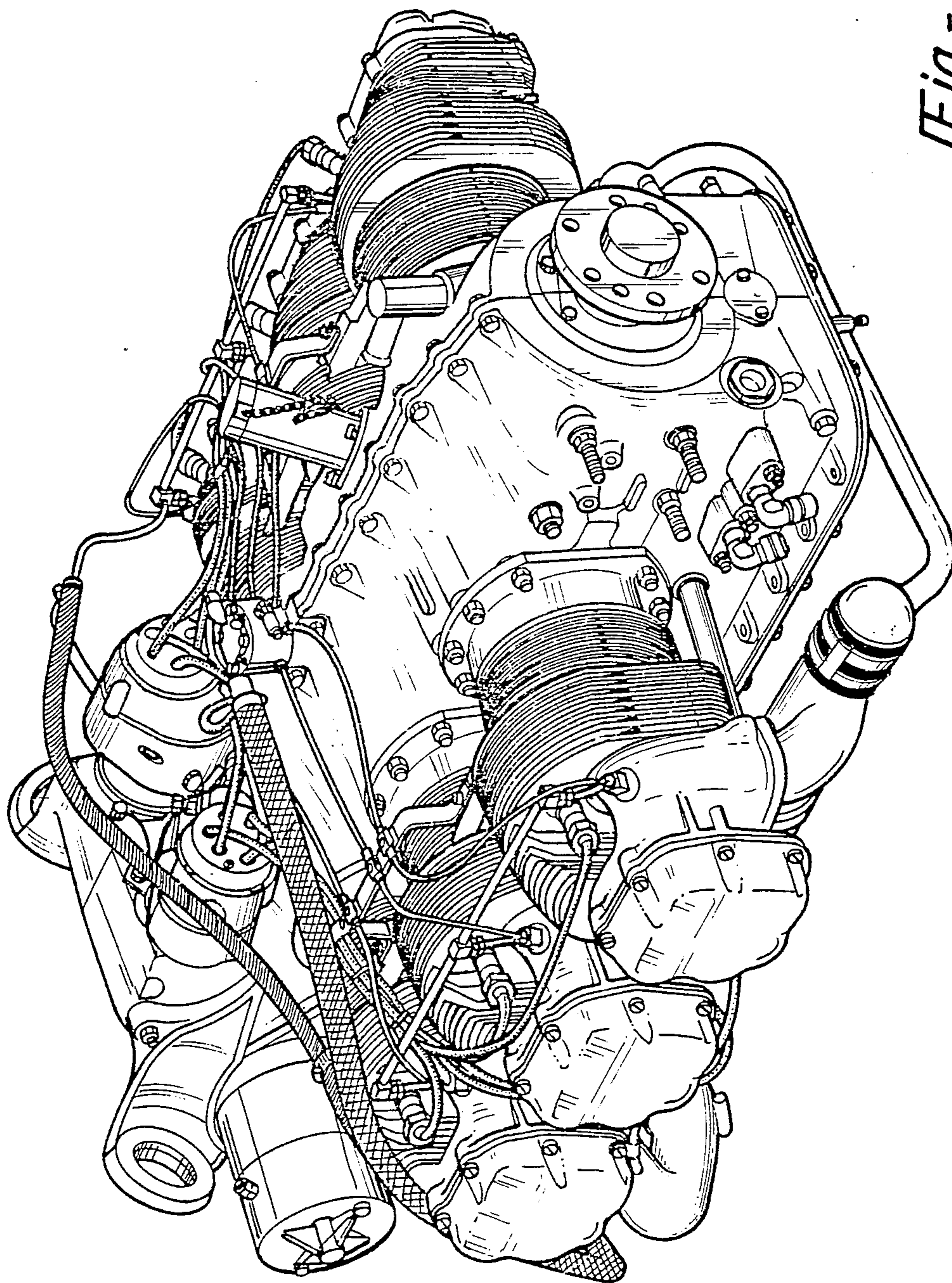
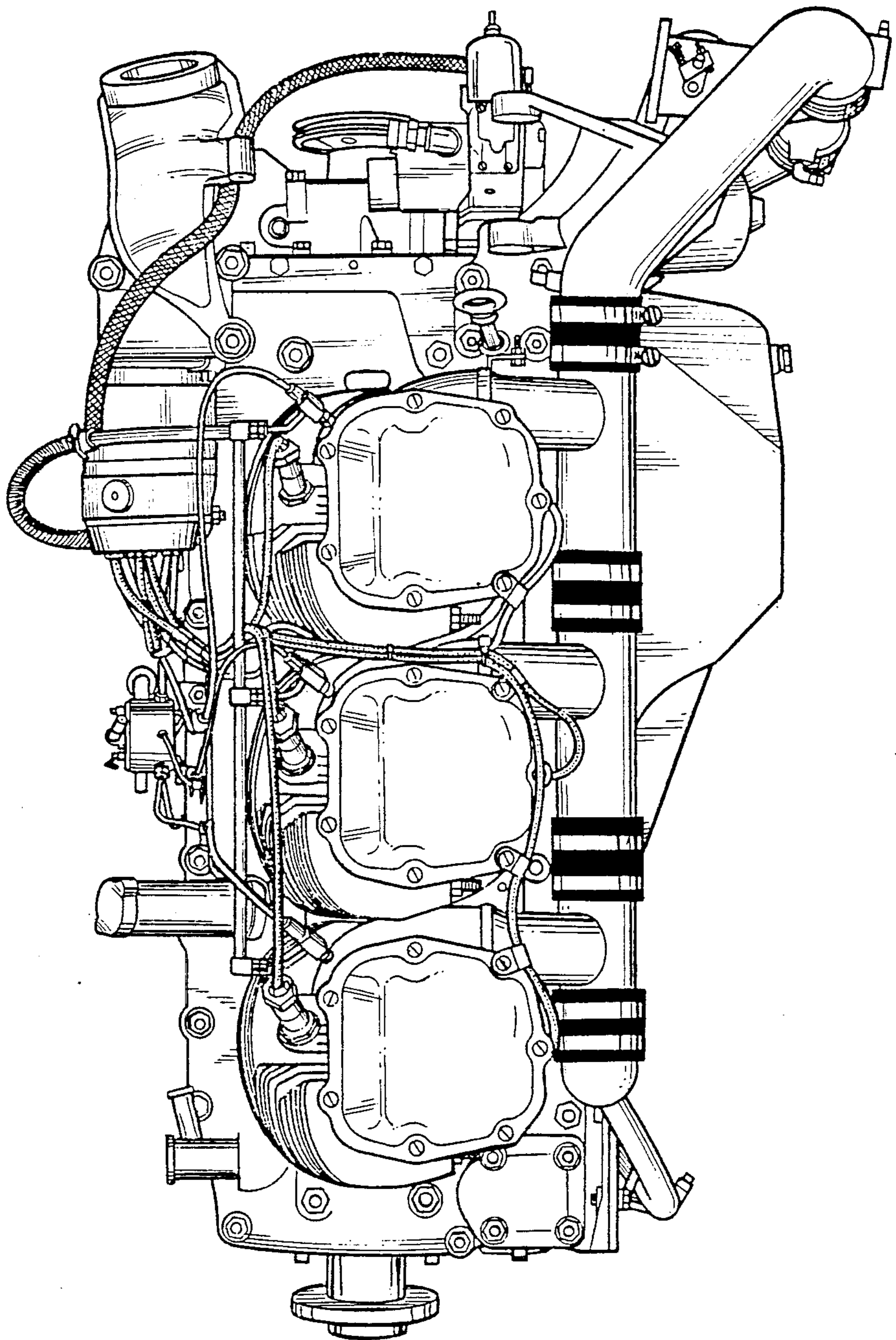

Fig - 1

Fig-2



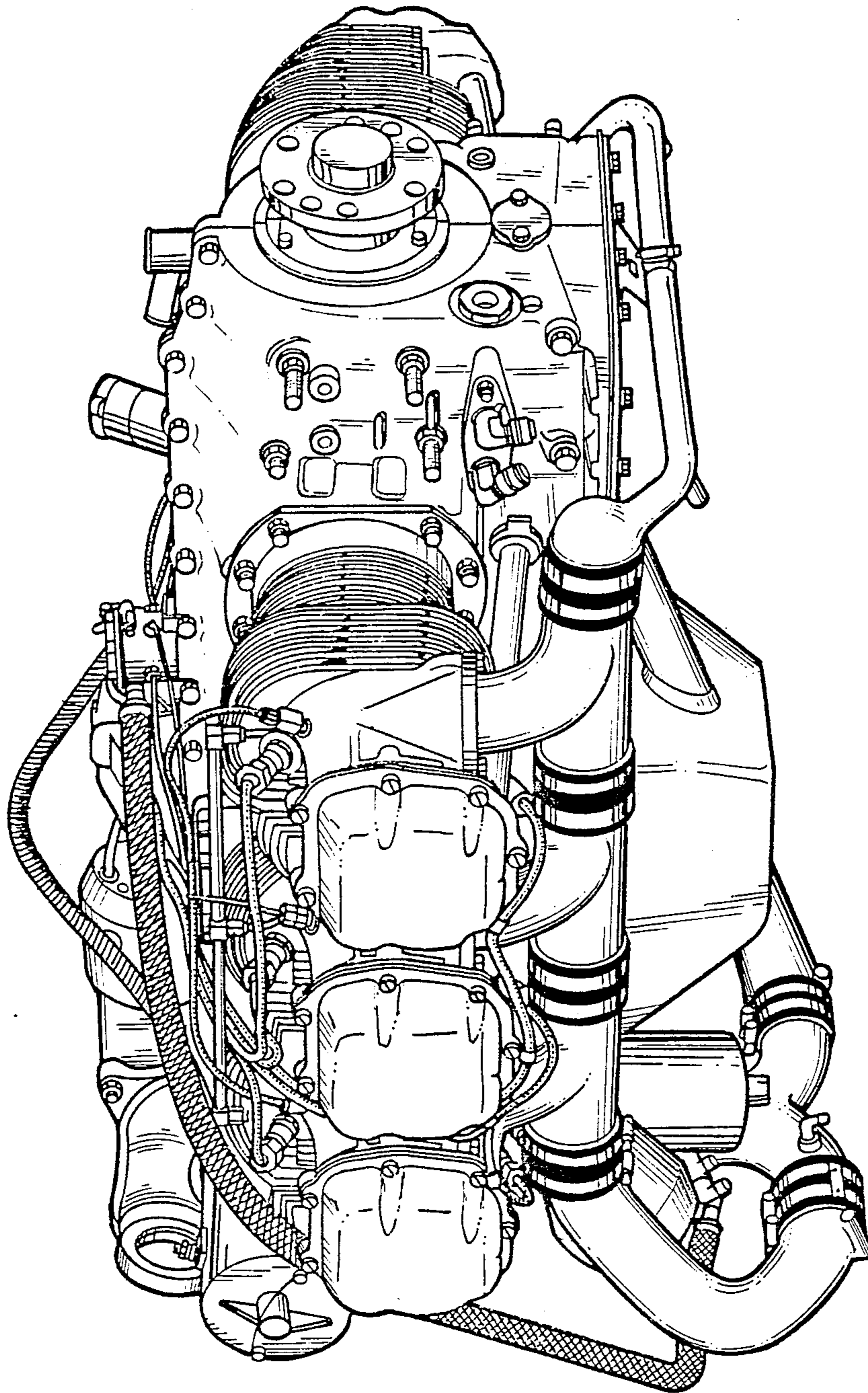

Fig - 3

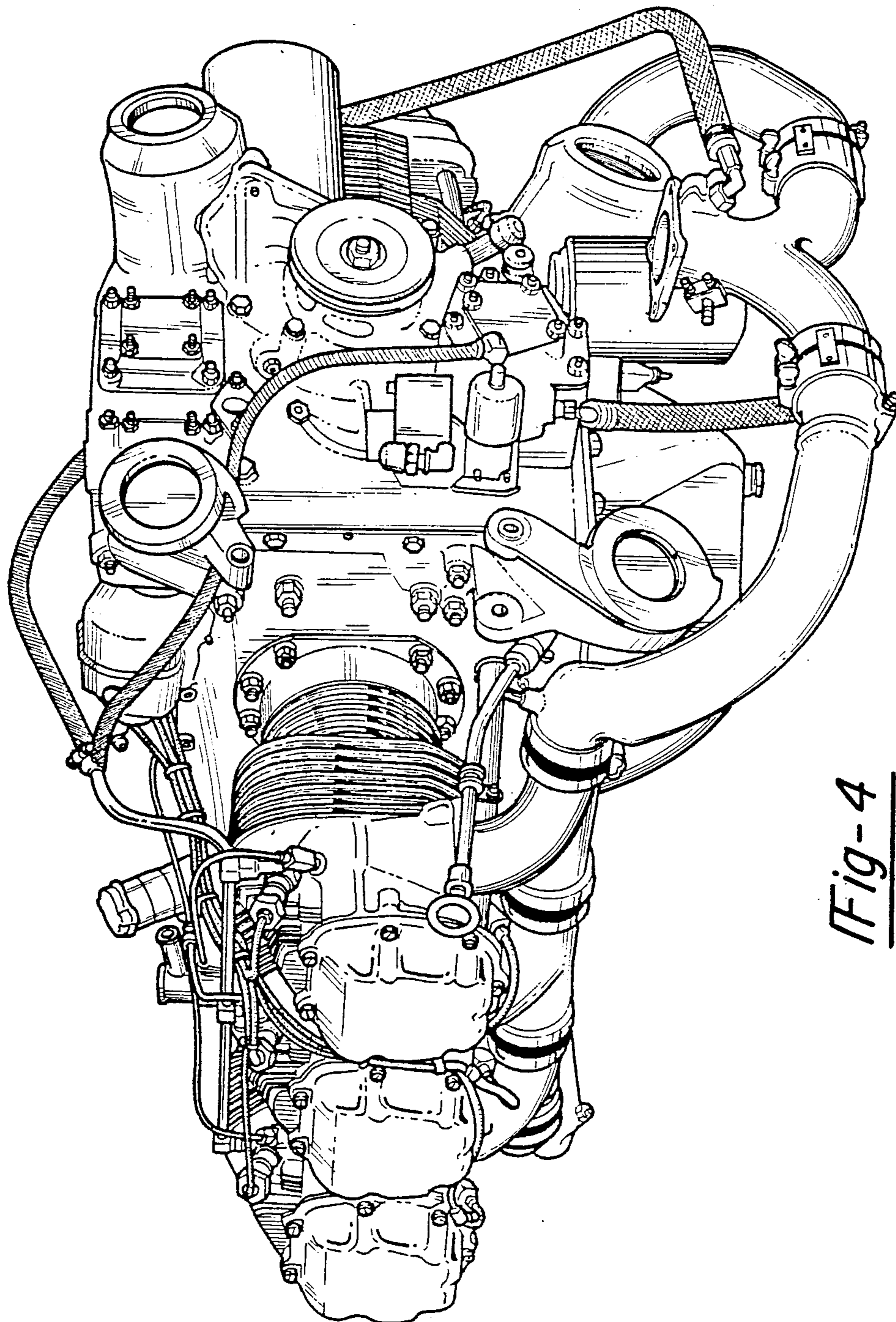

Fig-4

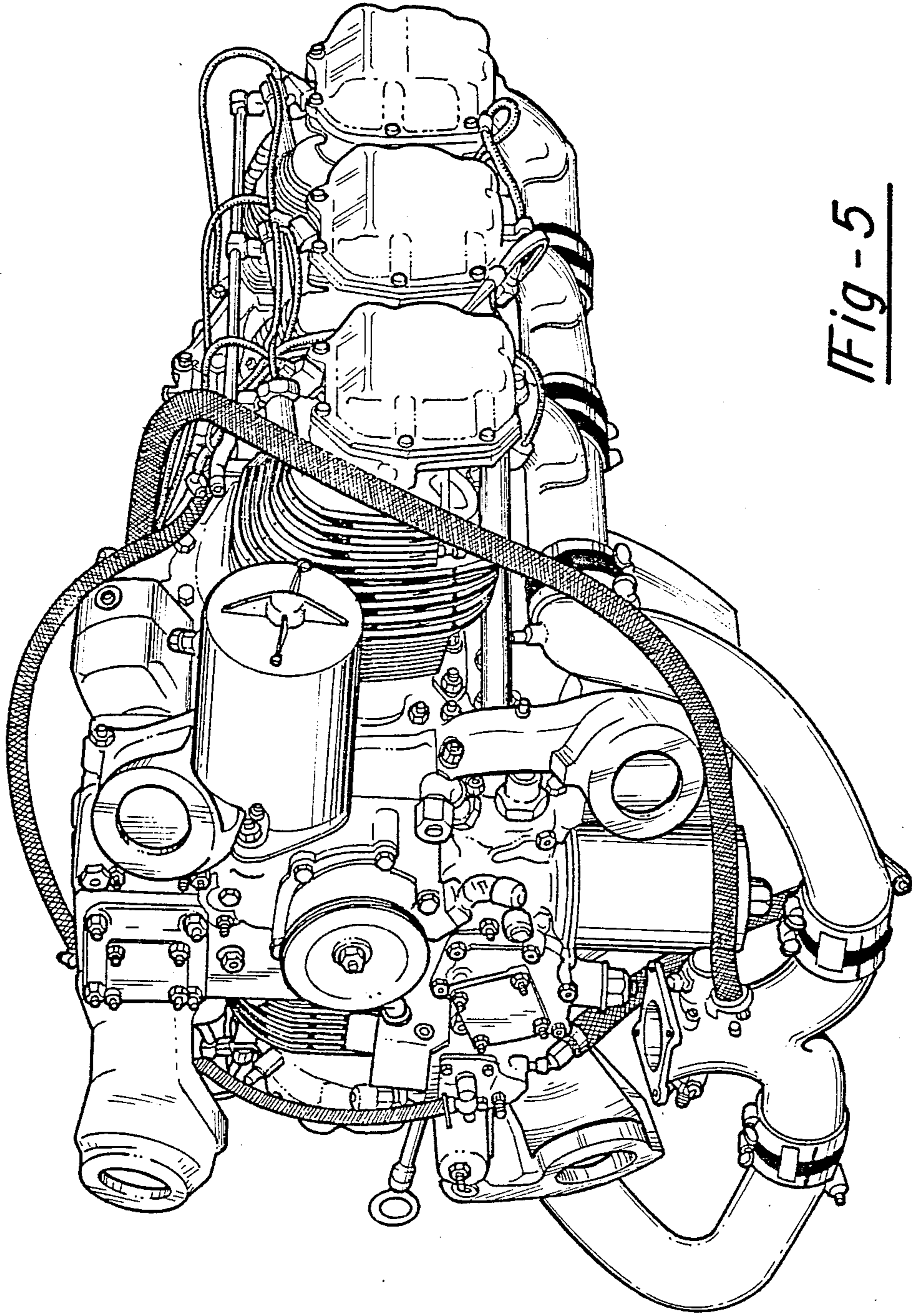

Fig - 5

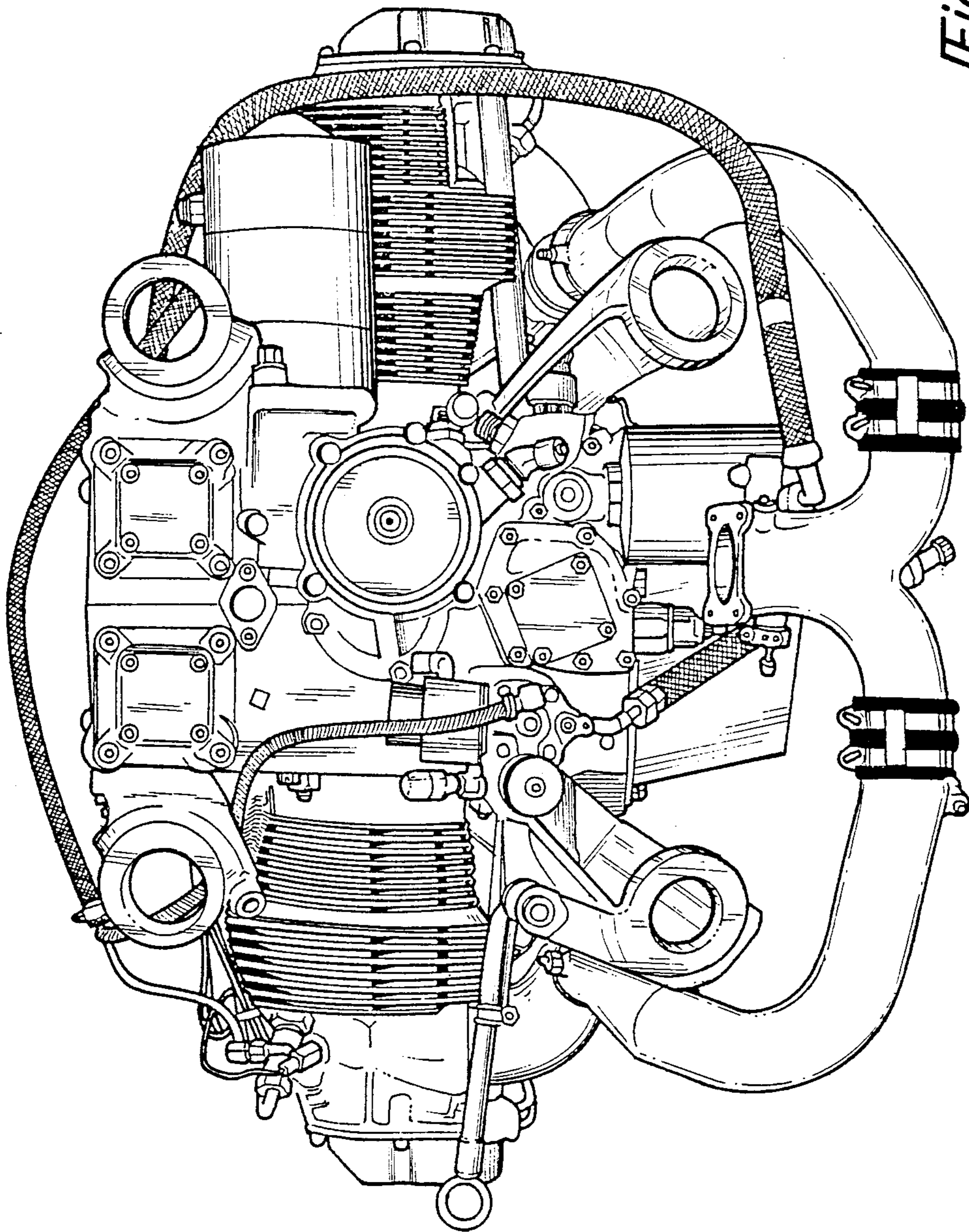

Fig - 6