

# United States Patent [19]

Keller

[11] Patent Number: Des. 293,096

[45] Date of Patent: \*\* Dec. 8, 1987

[54] SAILING VEHICLE

[76] Inventor: Robert N. Keller, 10388 Enterprise, Davisburg, Mich. 48019

[\*\*] Term: 14 Years

[21] Appl. No.: 899,322

[22] Filed: Aug. 22, 1986

[52] U.S. Cl. .... D12/304

[58] Field of Search ..... D12/300, 302, 303, 304; 114/61, 39.2, 39

[56] References Cited

## U.S. PATENT DOCUMENTS

D. 225,904	1/1973	Critcher	.....	D12/304
D. 268,577	4/1983	Gillberg	.....	D12/304
D. 274,238	6/1984	Mellinger et al.	.....	D12/304
D. 278,138	3/1985	Enfedaque	.....	D12/304
3,812,805	5/1974	Forssell et al.	.....	114/61
4,437,424	3/1984	Lord	.....	114/61
4,466,373	8/1984	Prade et al.	.....	114/39.2

4,569,301 2/1986 Pyburn ..... 114/61

## FOREIGN PATENT DOCUMENTS

2541648 8/1984 France ..... 114/61

*Primary Examiner*—James M. Gandy  
*Assistant Examiner*—Kay H. Chin  
*Attorney, Agent, or Firm*—Gifford, Groh, VanOphem, Sheridan, Sprinkle and Dolgorukov

[57] CLAIM

The ornamental design for a sailing vehicle, as shown.

## DESCRIPTION

FIG. 1 is a perspective view of a sailing vehicle showing my new design;  
FIG. 2 is a top plan view thereof;  
FIG. 3 is a left side elevational view thereof;  
FIG. 4 is a bottom plan view thereof;  
FIG. 5 is a front elevational view thereof;  
FIG. 6 is a rear elevational view thereof; and  
FIG. 7 is a right side elevational view thereof.

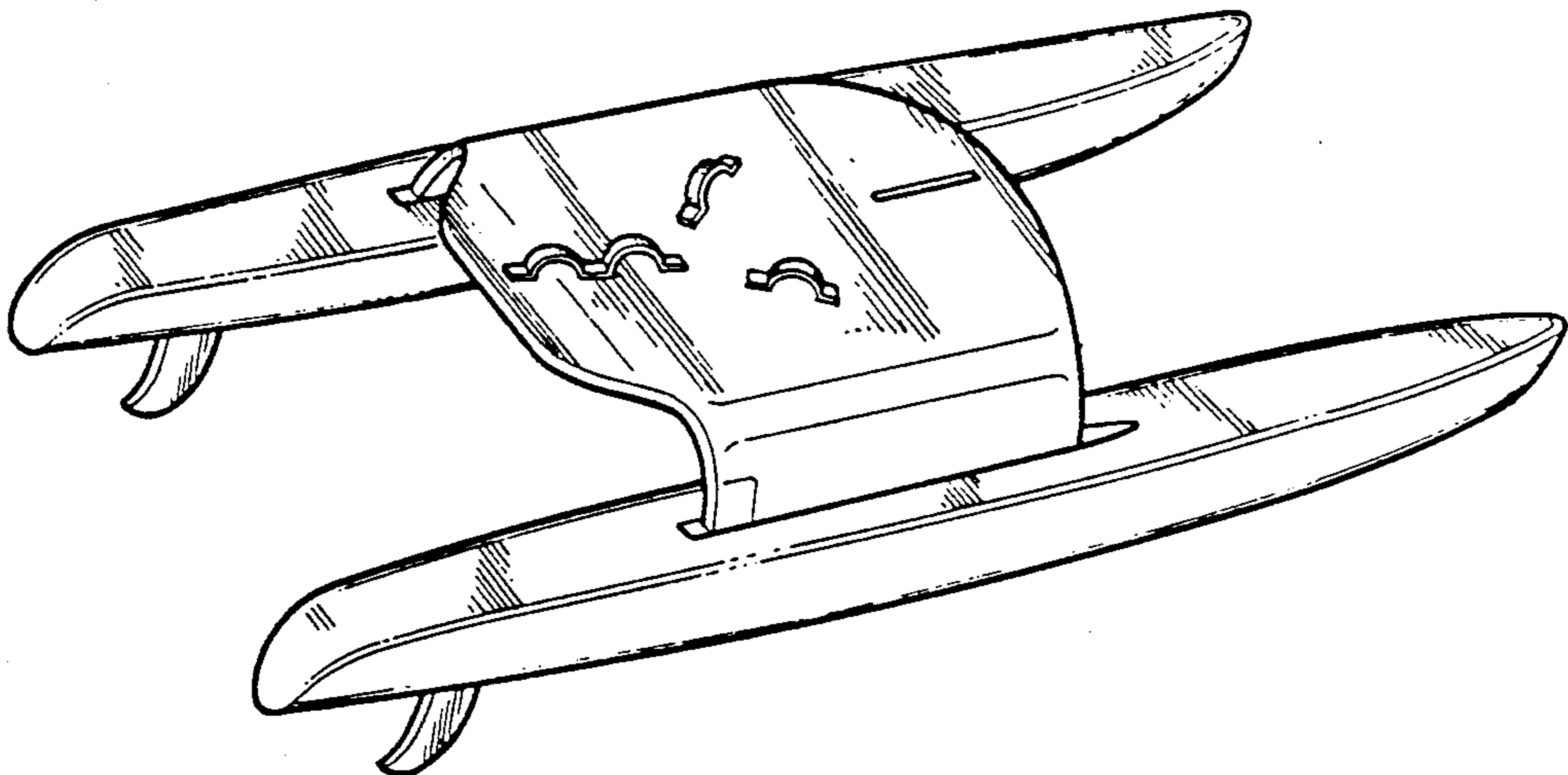

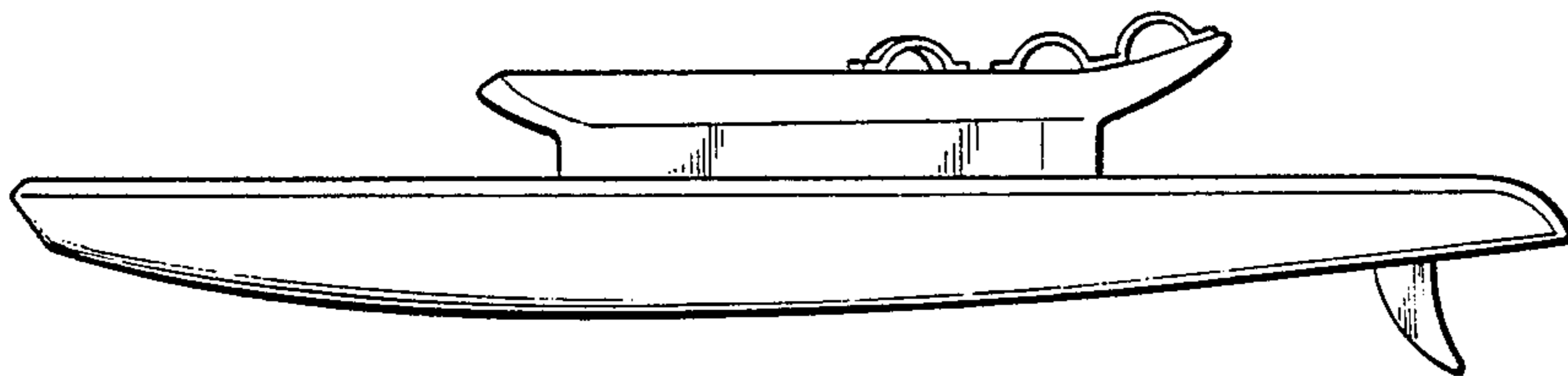
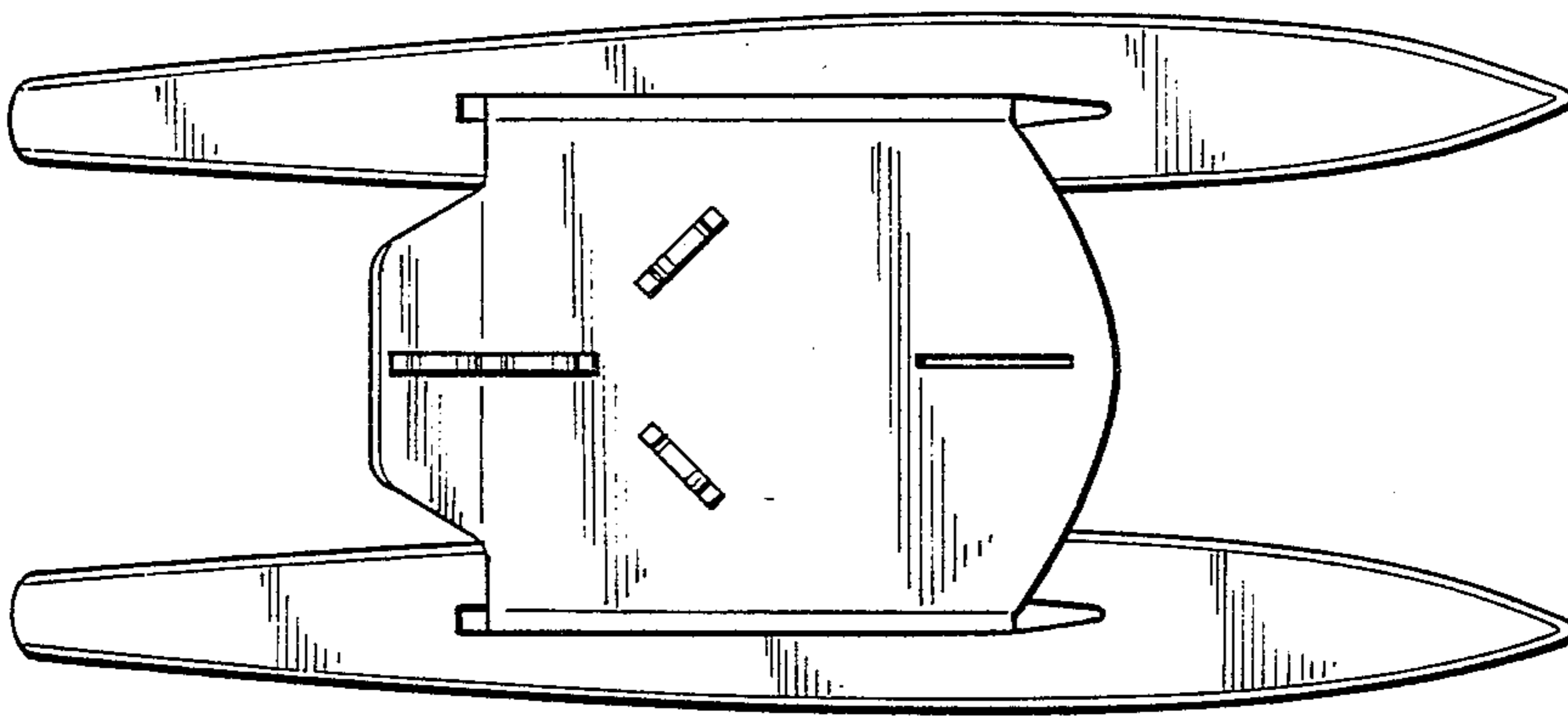
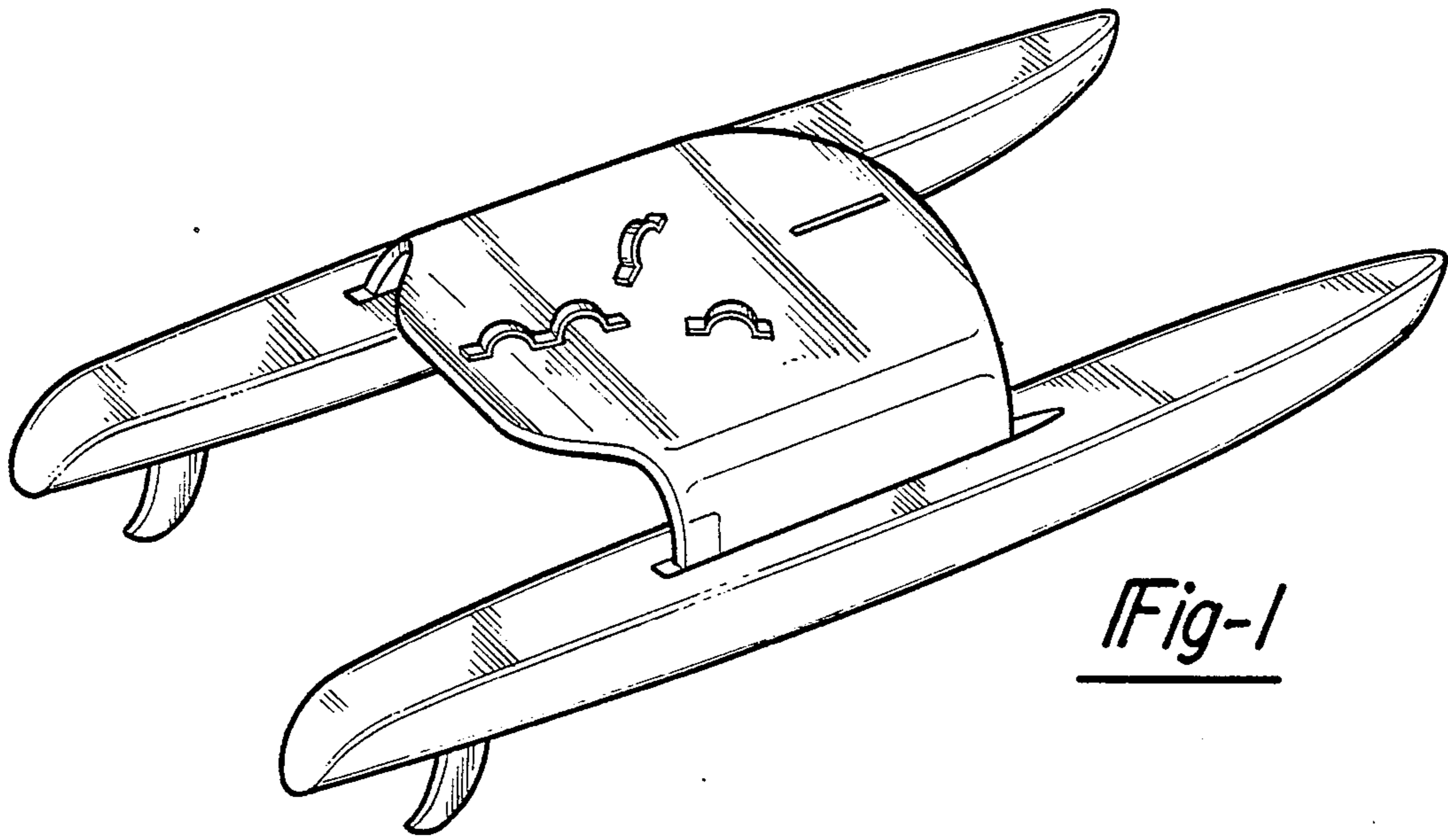

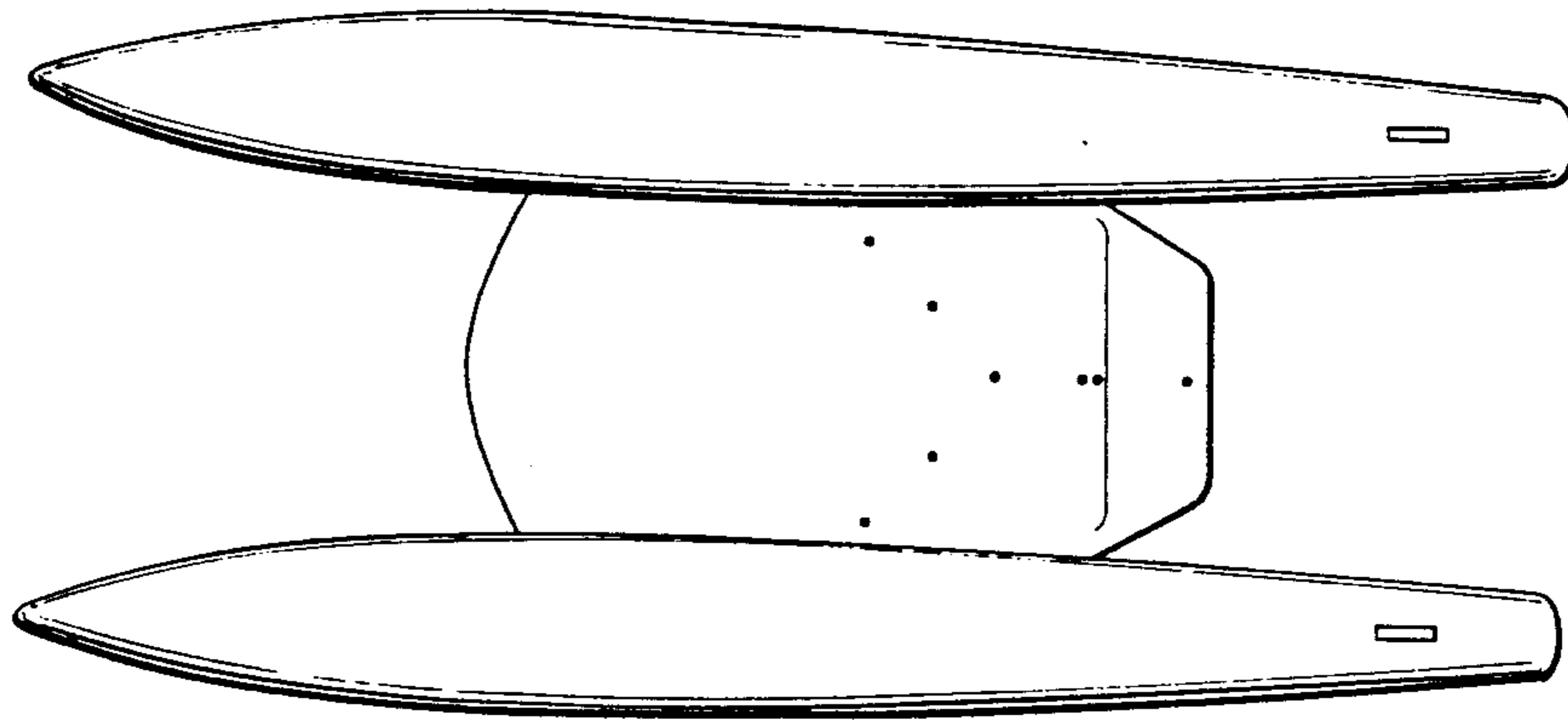

Fig-4

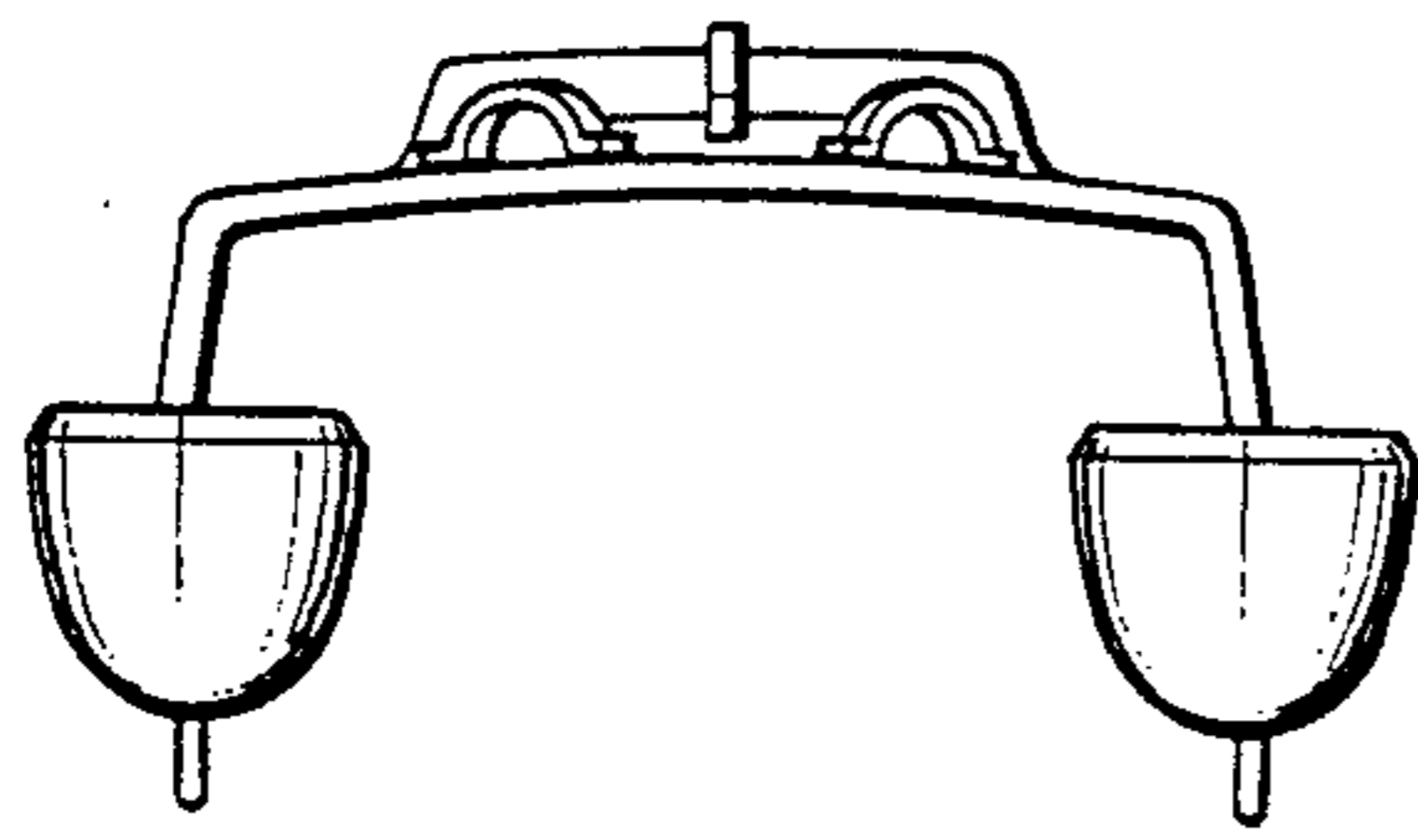

Fig-5

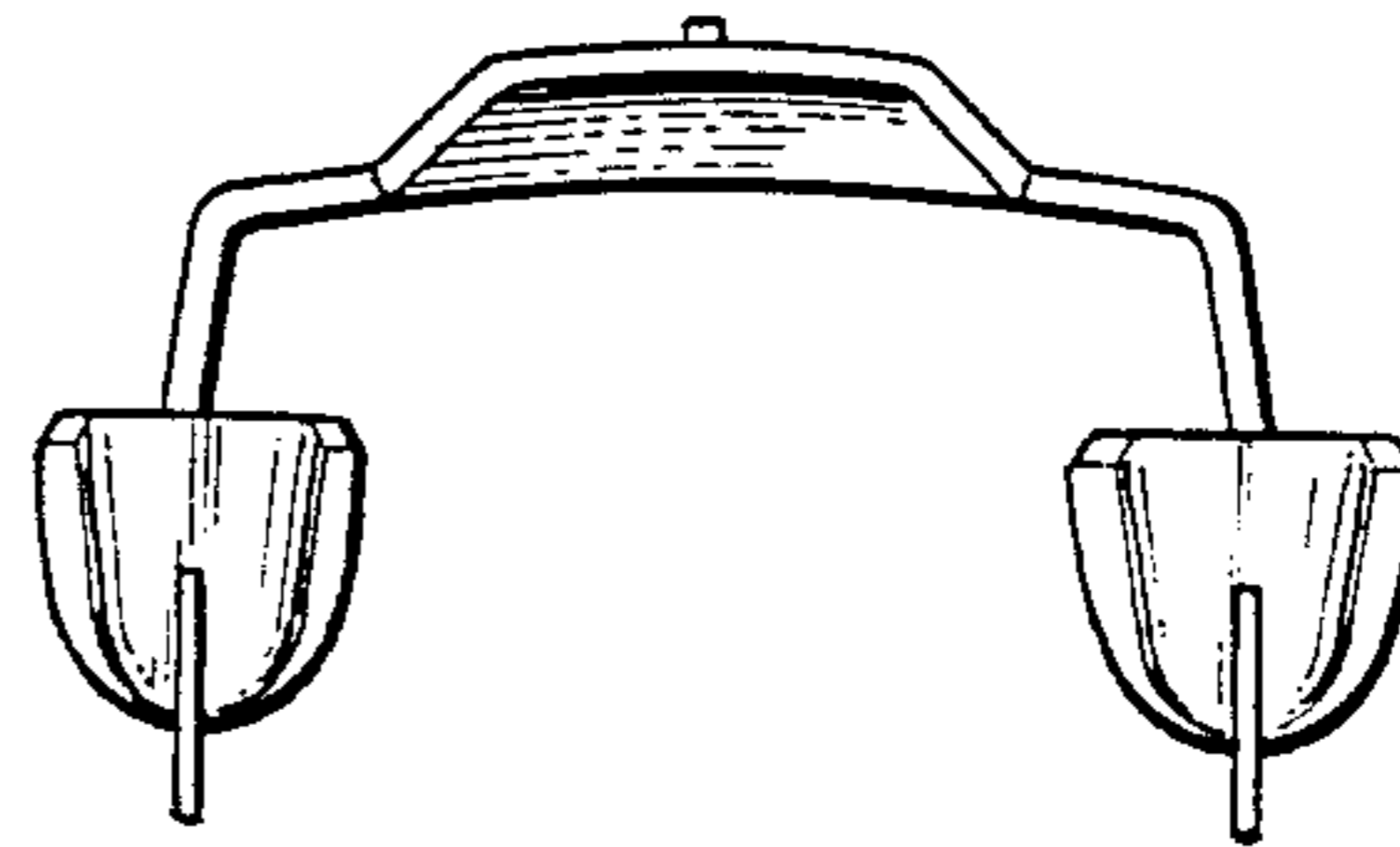

Fig-6

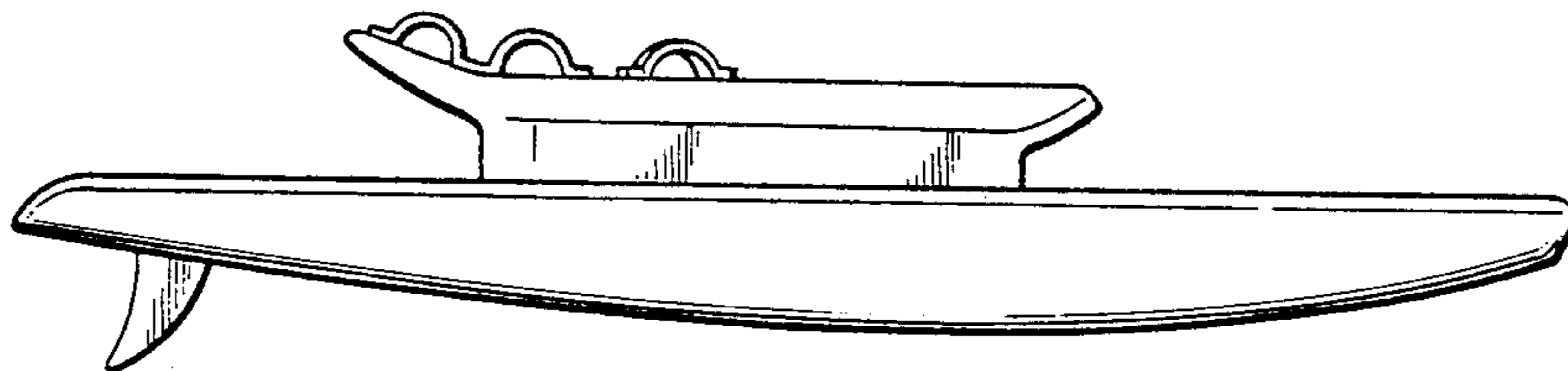

Fig-7