

# United States Patent [19]

Lessel

[11] Patent Number: Des. 292,973

[45] Date of Patent: \*\* Dec. 1, 1987

[54] WETBIKE WATER INLET MANIFOLD

4,628,852 12/1986 Nishida ..... 114/270

[76] Inventor: Chris L. Lessel, 15205 Raymer St.,  
Van Nuys, Calif. 91405

### FOREIGN PATENT DOCUMENTS

144270 6/1985 France ..... 114/270

[\*\*] Term: 14 Years

[21] Appl. No.: 879,795

[22] Filed: Jun. 27, 1986

[52] U.S. Cl. .... D12/317; D12/307

[58] Field of Search ..... D12/317, 318, 307;  
440/47, 38; 114/270

Primary Examiner—James M. Gandy  
Assistant Examiner—Kay H. Chin  
Attorney, Agent, or Firm—Richard D. Slehofer

### [57] CLAIM

The ornamental design for a wetbike water inlet manifold, as shown and described.

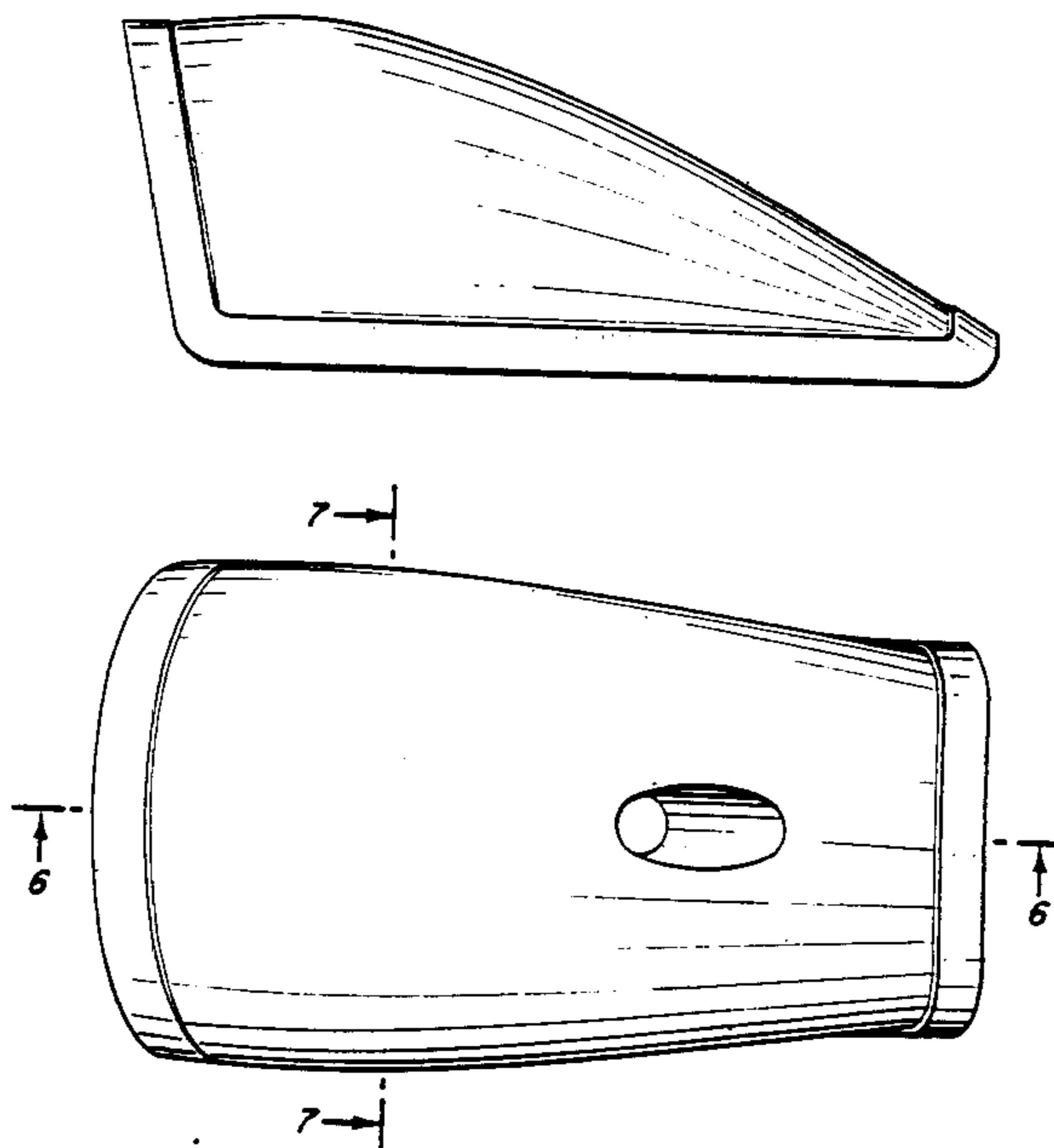
### [56] References Cited

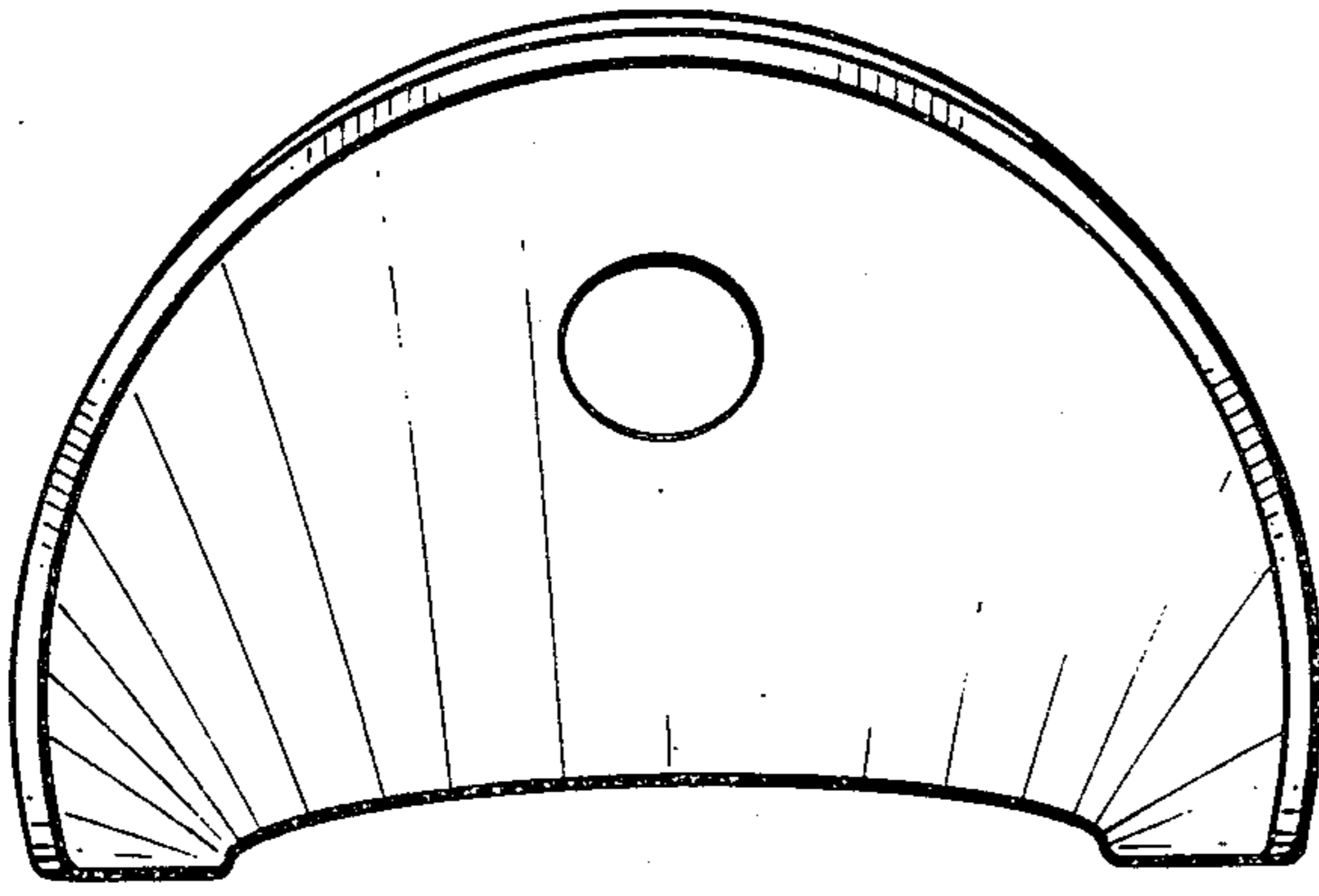
#### U.S. PATENT DOCUMENTS

D. 242,782	12/1976	Tyler	.....	D12/307
3,174,454	3/1965	Kenefick	.....	440/47
3,280,786	10/1966	Rowell	.....	440/38/
3,324,822	6/1967	Carter	.....	440/38
3,369,518	2/1968	Jacobson	.....	440/38
3,840,319	10/1974	Rhoda	.....	440/38
3,934,538	1/1976	Canazzi	.....	440/43
3,943,876	3/1976	Kiekhaefer	.....	440/38
4,237,812	12/1980	Richardson	.....	440/38

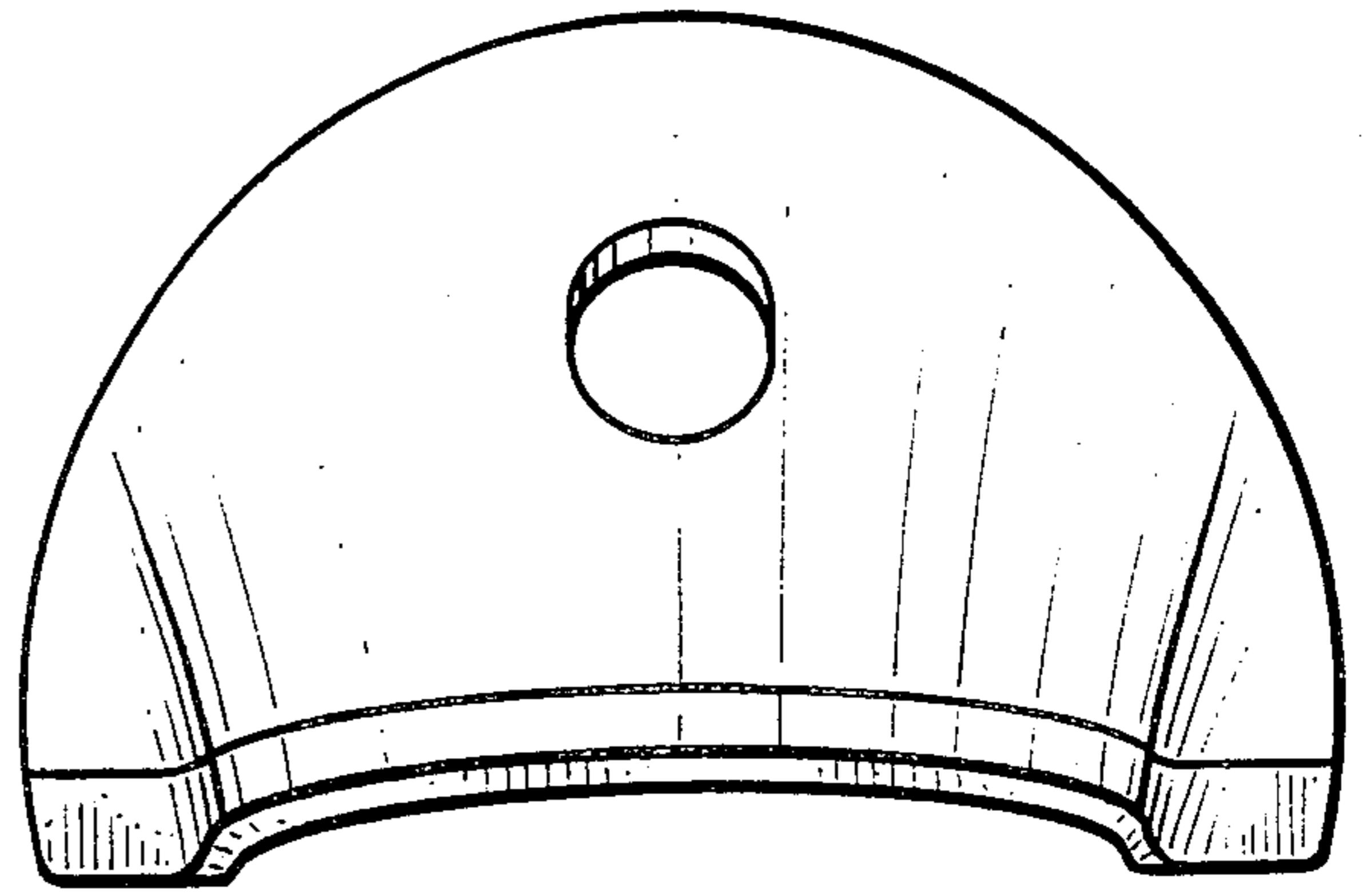
### DESCRIPTION

FIG. 1 is a front-elevational view of a wetbike water inlet manifold showing my new design;  
FIG. 2 is a side elevational view thereof;  
FIG. 3 is a rear elevational view thereof;  
FIG. 4 is a top plan view thereof;  
FIG. 5 is a bottom plan view thereof;  
FIG. 6 is a sectional view taken along line 6—6 of FIG. 4; and,  
FIG. 7 is a sectional view taken along line 7—7 of FIG. 4.

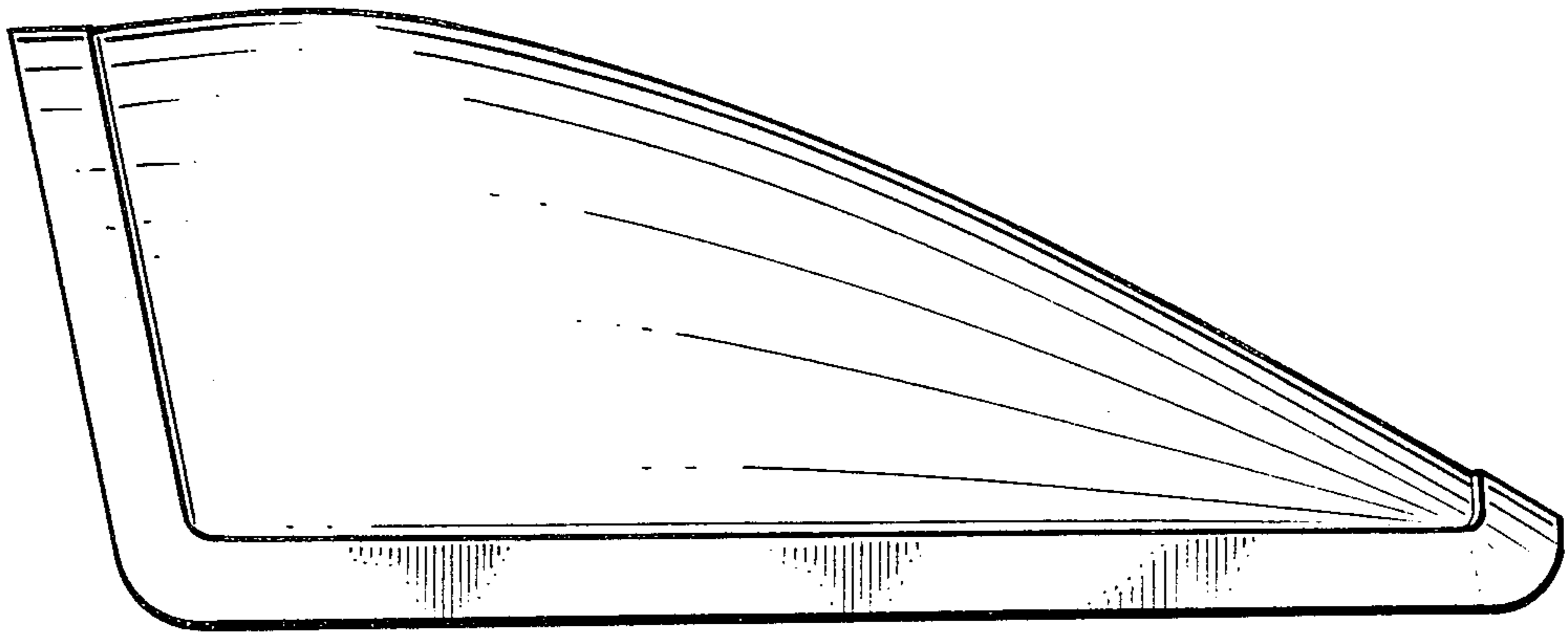




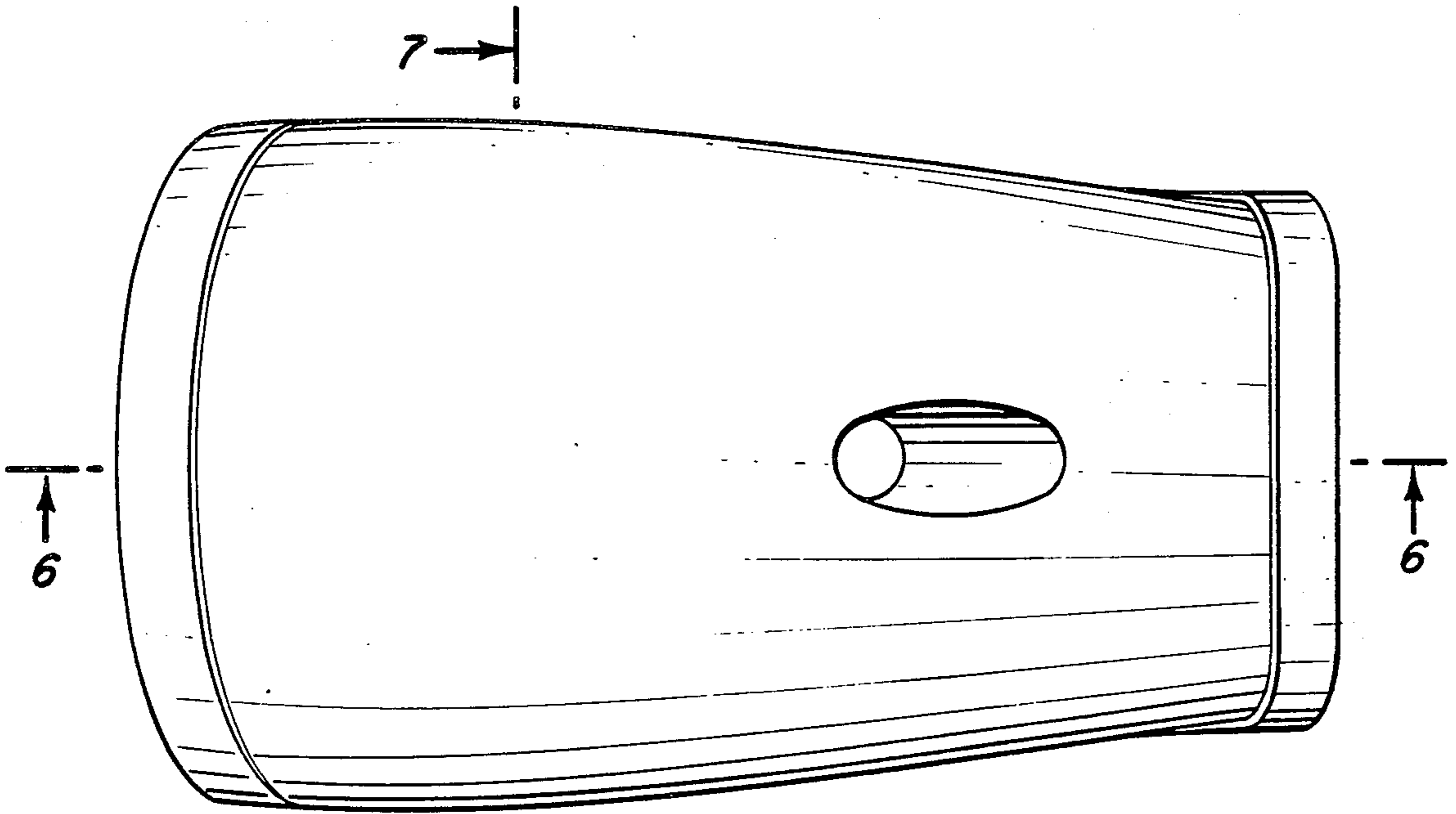
*Fig. 1.*



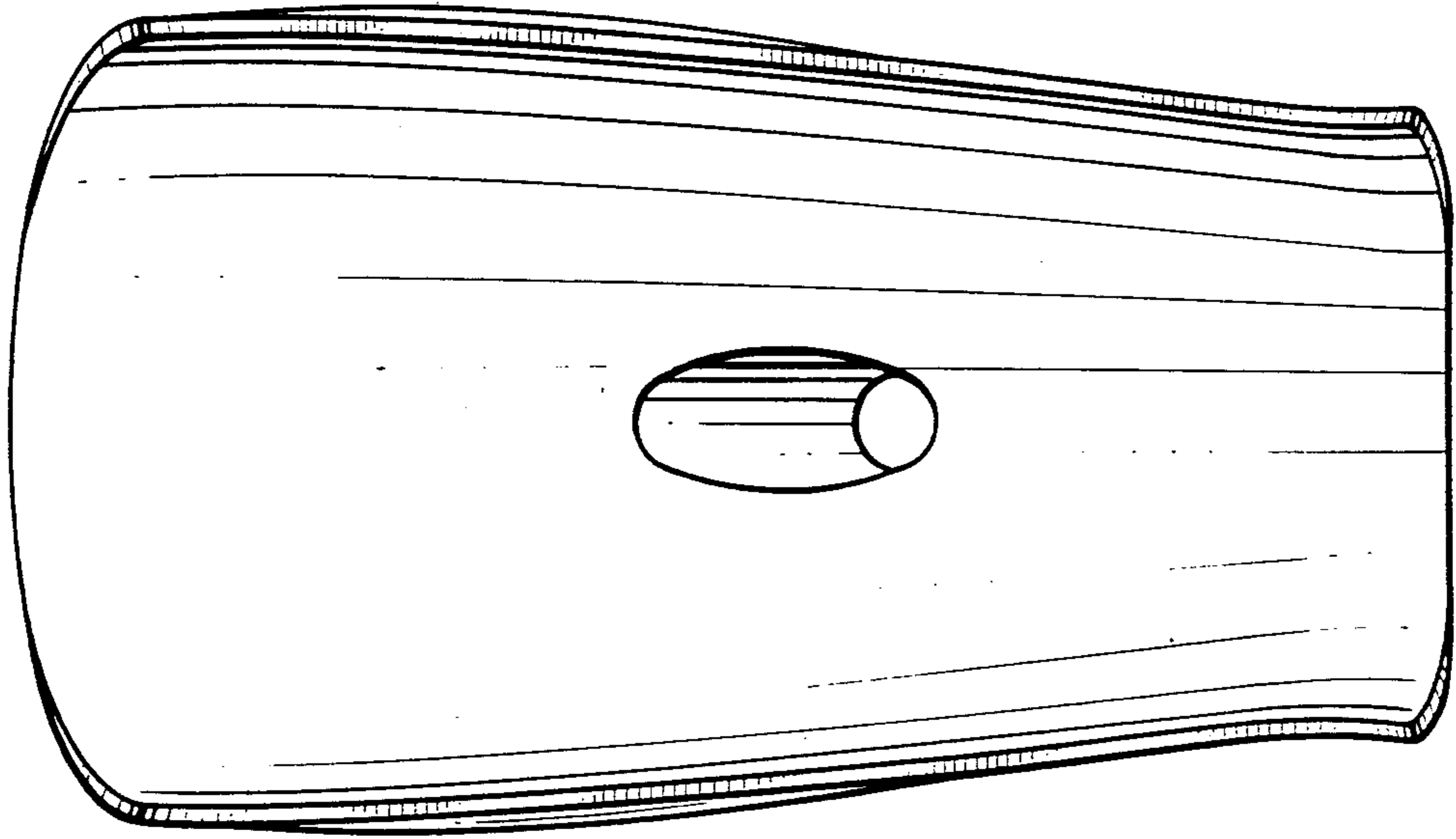
*Fig. 3.*



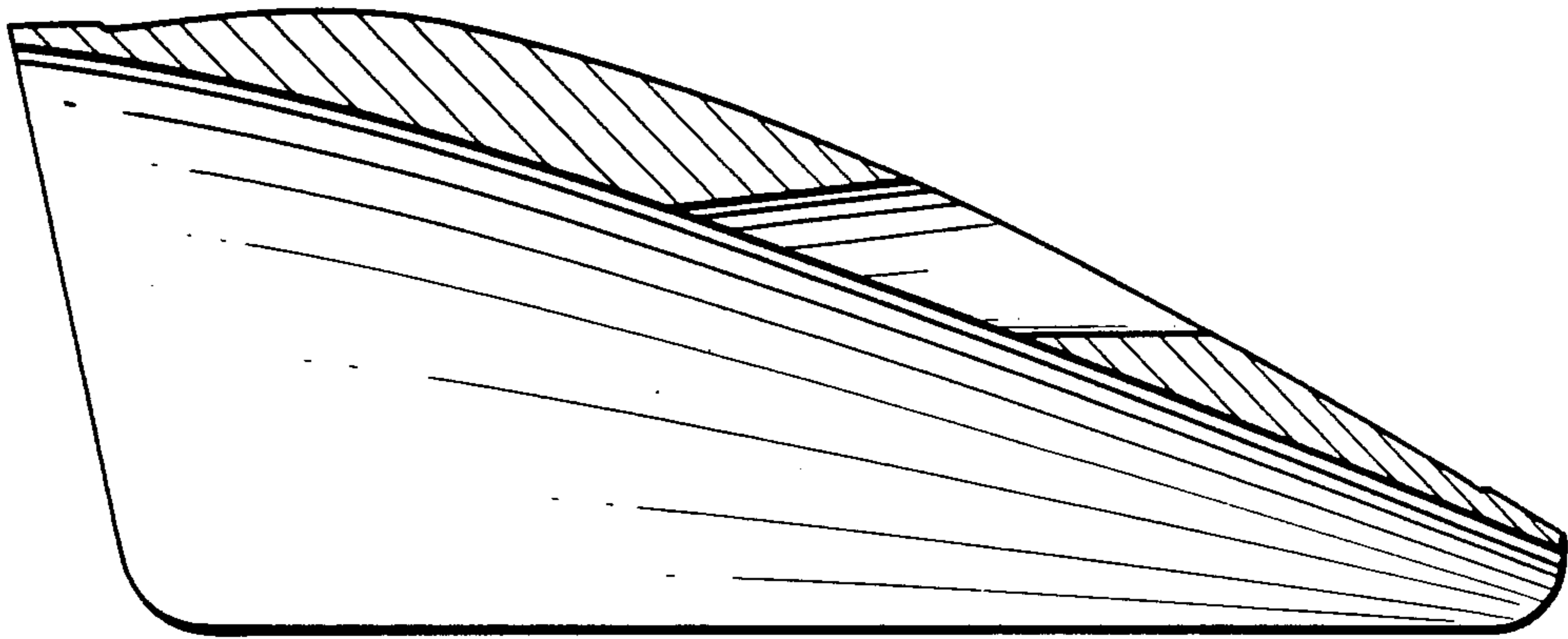
*Fig. 2.*



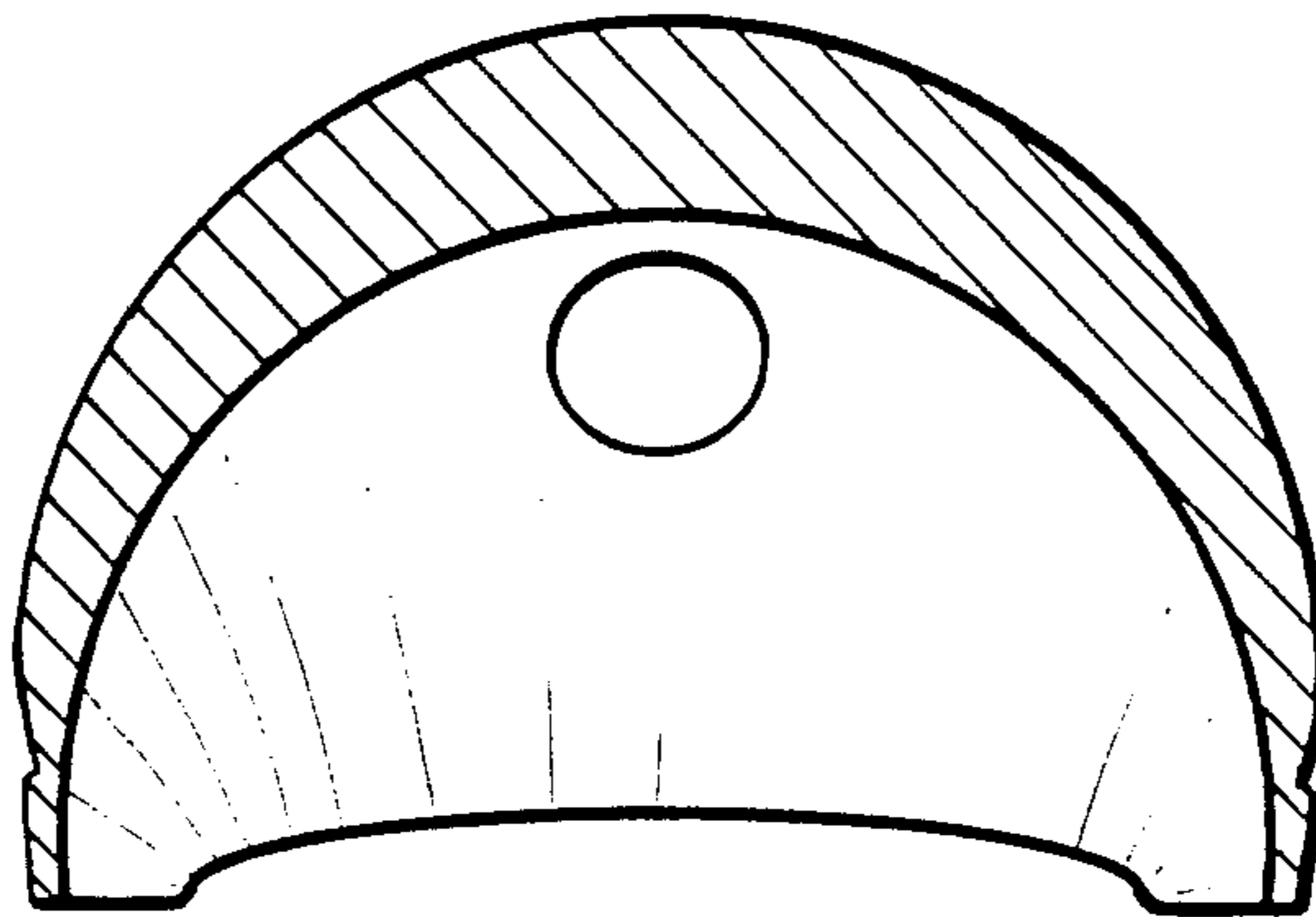
*Fig. 4.*



*Fig. 5.*



*Fig. 6.*



*Fig. 7.*