

United States Patent [19]

Drake

[11] Patent Number: **Des. 292,909**

[45] Date of Patent: **** Nov. 24, 1987**

[54] AIRPLANE

D. 276,995 1/1985 Drake D12/339

[76] Inventor: **Anthony F. Drake**, P.O. Box 31192,
Santa Barbara, Calif. 93130-1192

OTHER PUBLICATIONS

Jane's Pocket Book of Light Aircraft, edited by J. W. R. Taylor, (1976), p. 107, FFA AS.202 Bravo.
Flight Int'l., Feb. 1984, p. 453, Trago Mills, SAH 1.
Flight Int'l., Aug. 1985, p. 26, Oshkosh '85, (top).

[**] Term: **14 Years**

Primary Examiner—James M. Gandy
Assistant Examiner—Kay H. Chin

[21] Appl. No.: **727,578**

[22] Filed: **Apr. 26, 1985**

[52] U.S. Cl. **D12/319; D12/344**

[58] Field of Search **D12/319, 322, 336, 337,
D12/338; 244/13**

[57] CLAIM

The ornamental design for an airplane, as shown.

[56] References Cited

U.S. PATENT DOCUMENTS

D. 131,295	2/1942	Burton et al.	D12/336
D. 146,162	12/1946	Woods	D12/343
D. 150,692	8/1948	Glasgow et al.	D12/339
D. 158,817	5/1950	Thieblot	D12/341
D. 179,348	12/1956	Johnson	D12/342 X
D. 183,675	10/1958	Begin et al.	D12/342
D. 191,019	8/1961	Thieblot	D12/342 X

DESCRIPTION

FIG. 1 is a top plan view of an airplane showing my new design;

FIG. 2 is a left side elevation view thereof;

FIG. 3 is a right side elevation view thereof;

FIG. 4 is a bottom plan view thereof;

FIG. 5 is a front elevation view thereof;

FIG. 6 is a rear elevation view thereof.

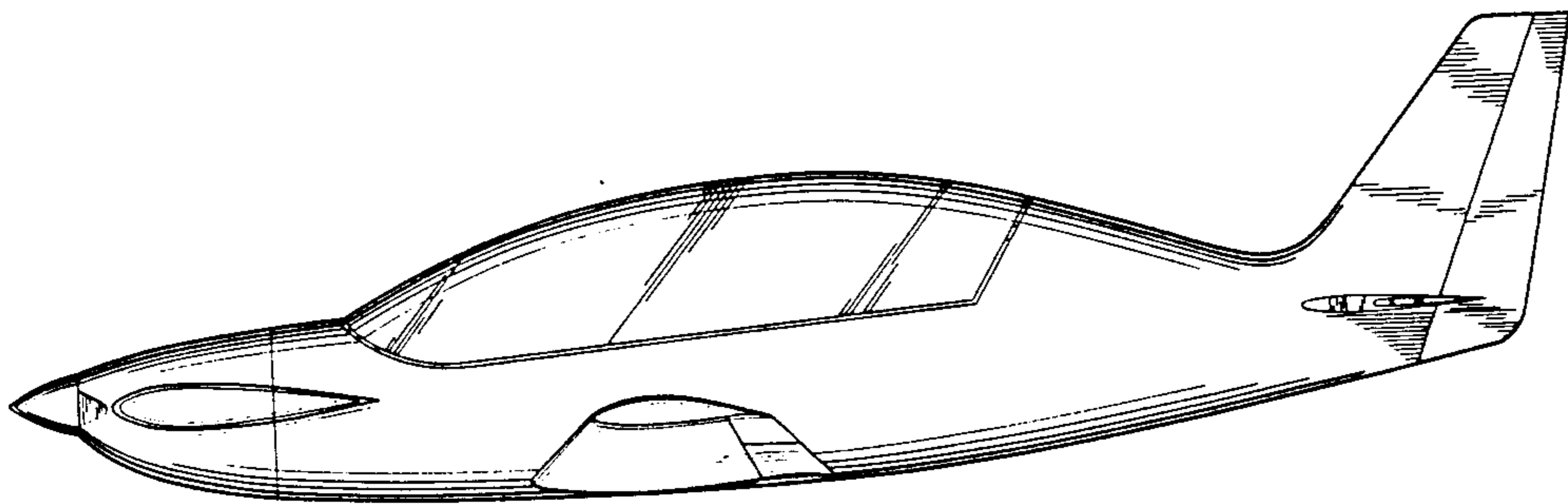
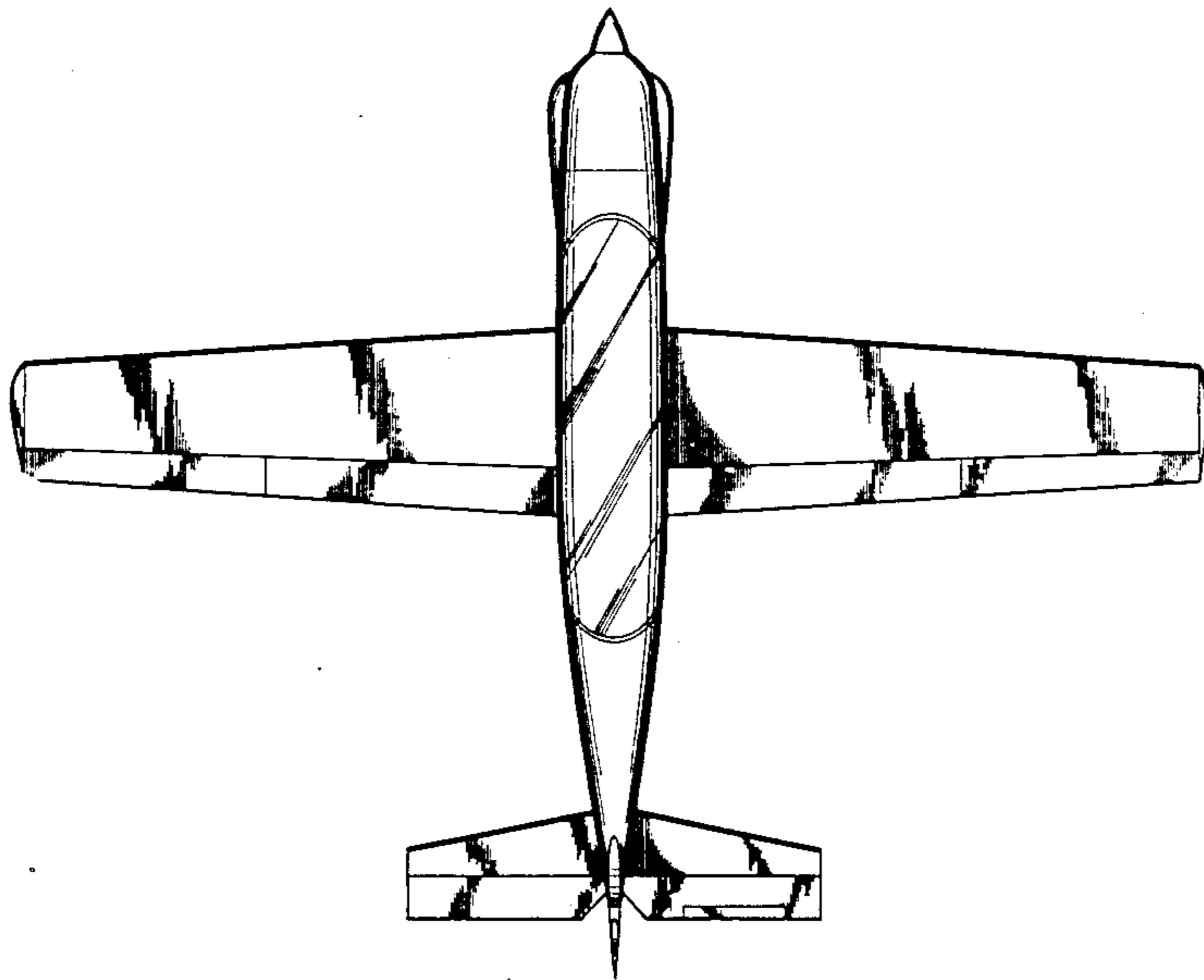

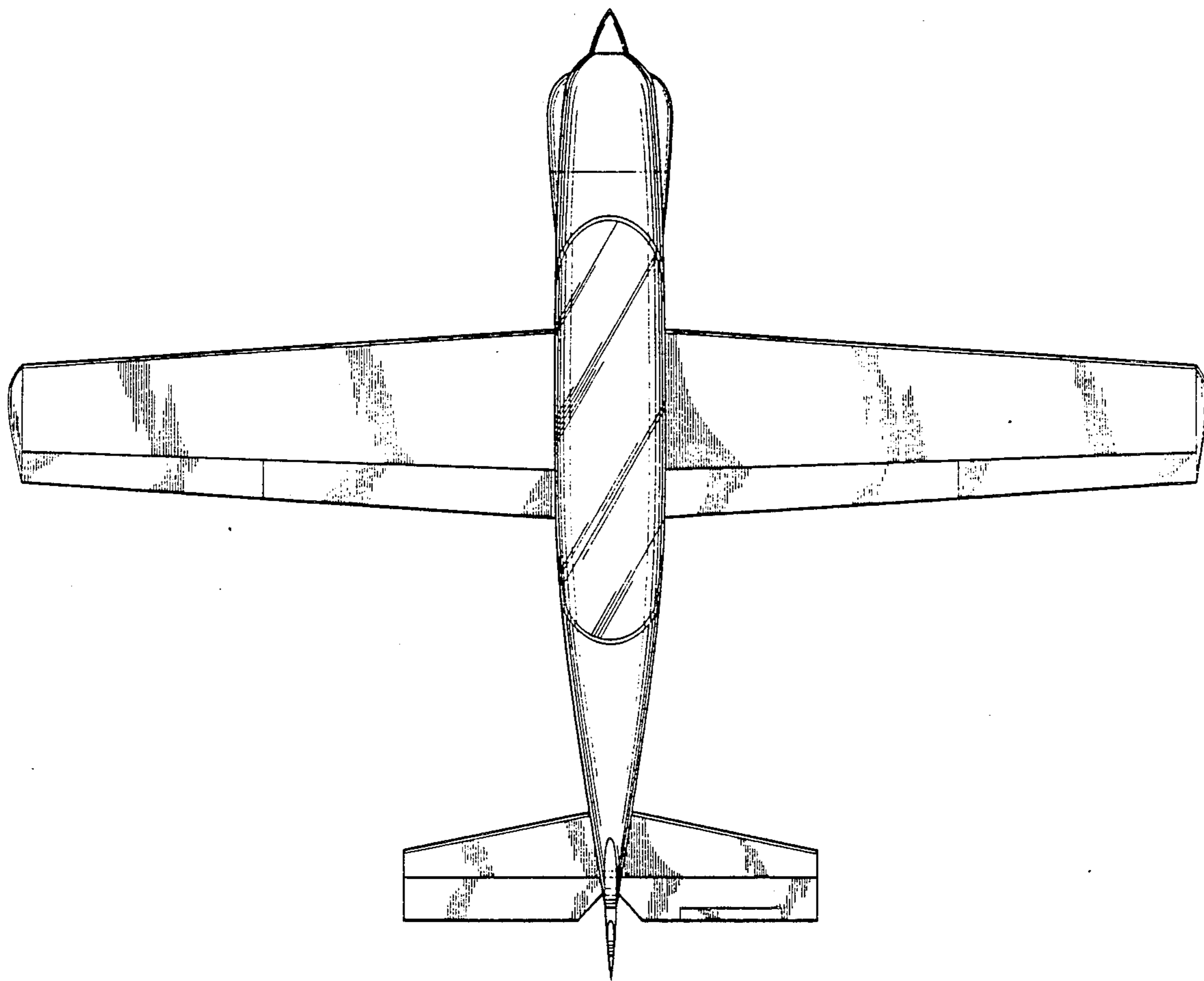

FIG 1

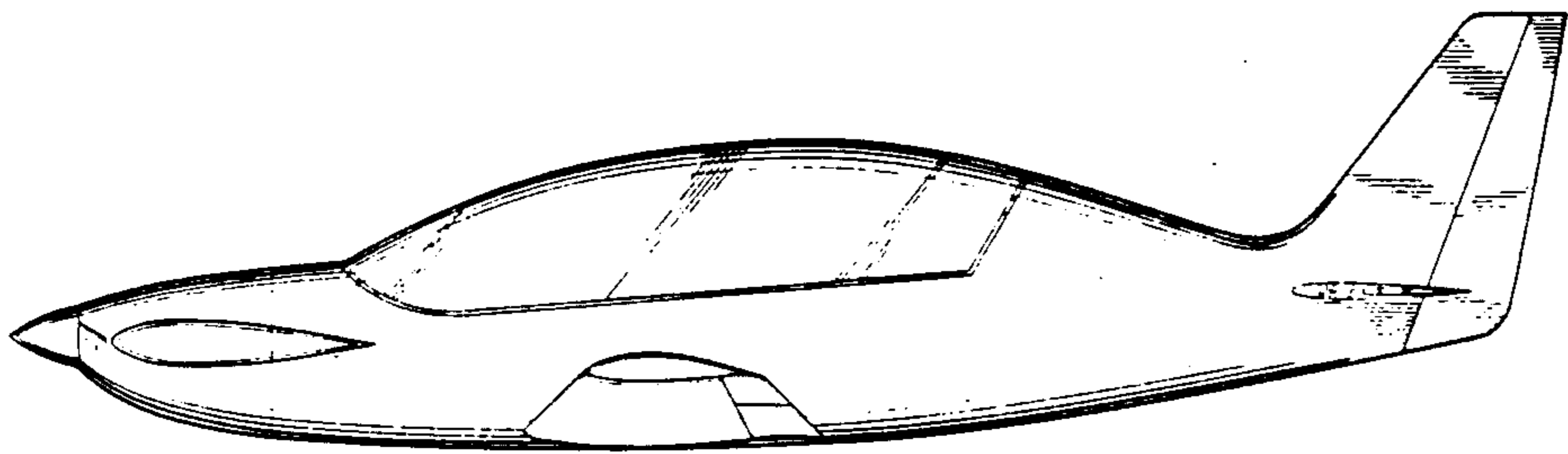

FIG 2

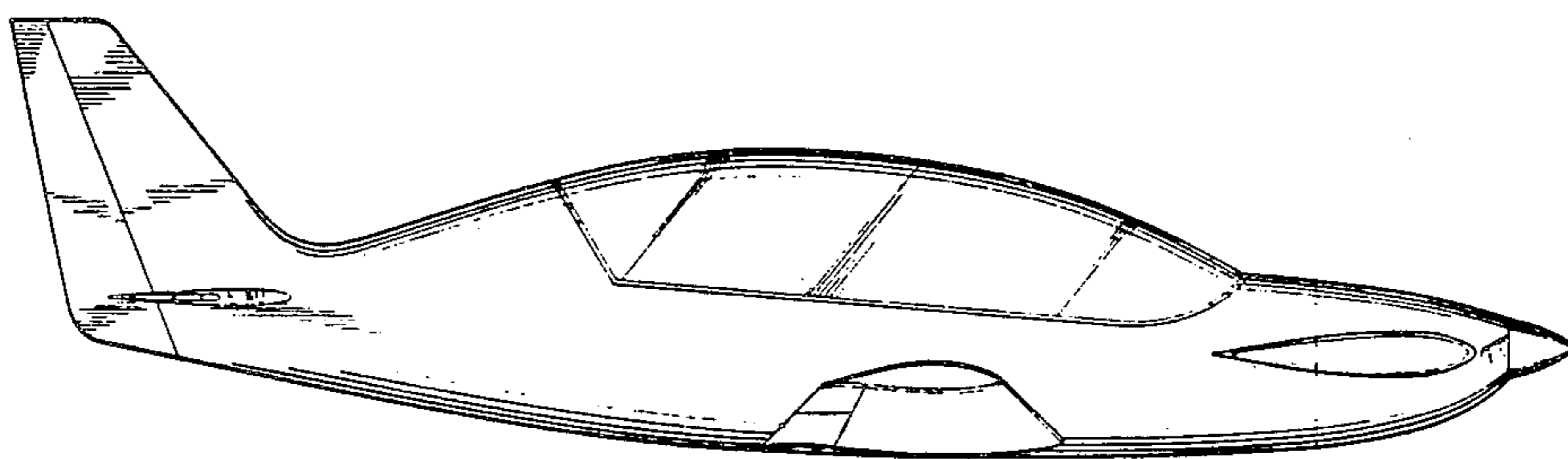

FIG 3

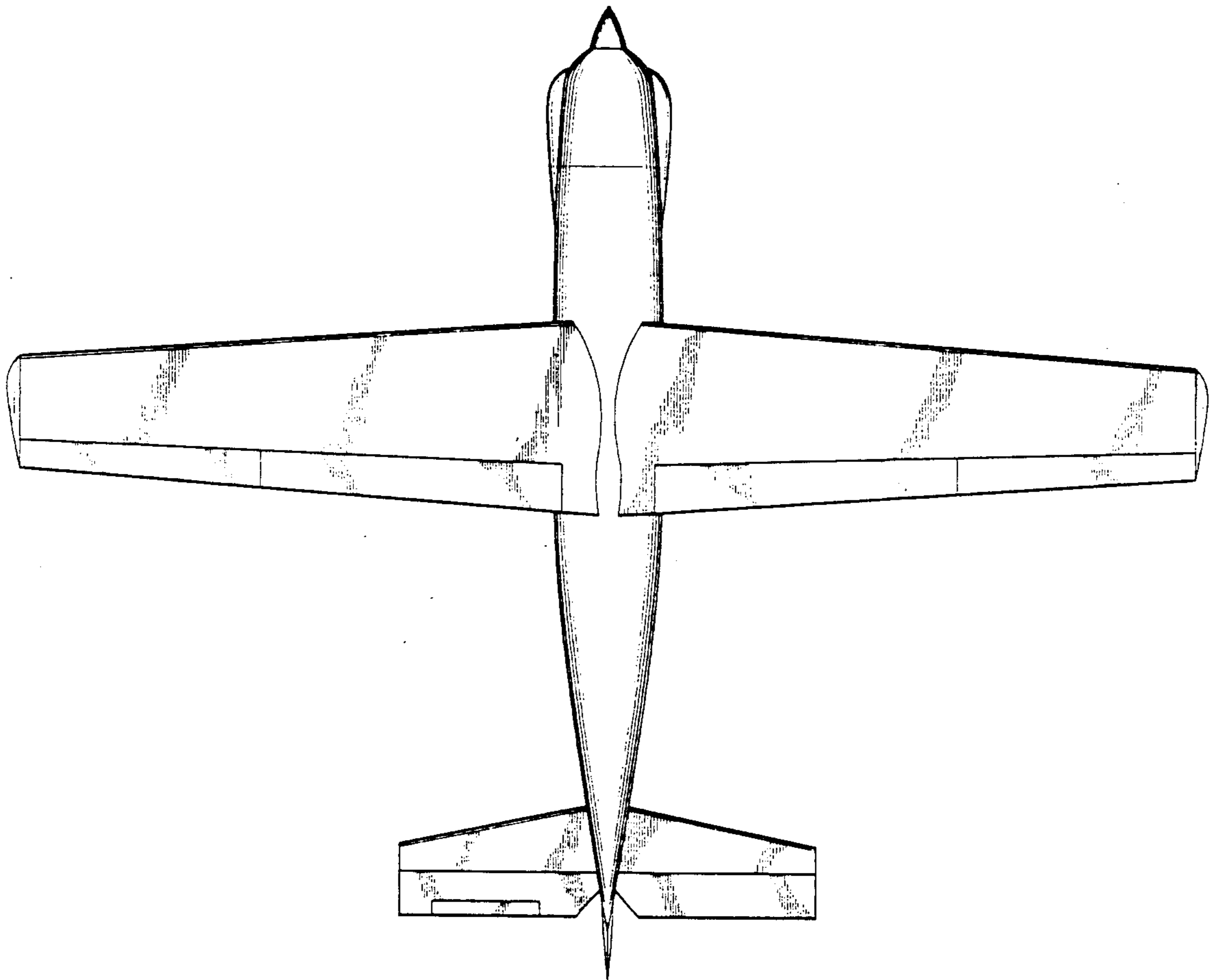

FIG 4

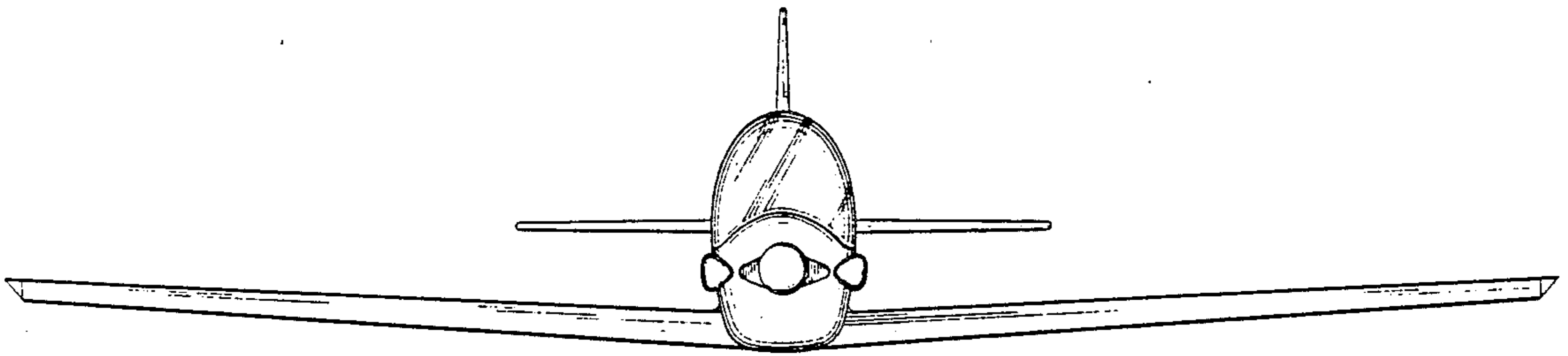

FIG 5

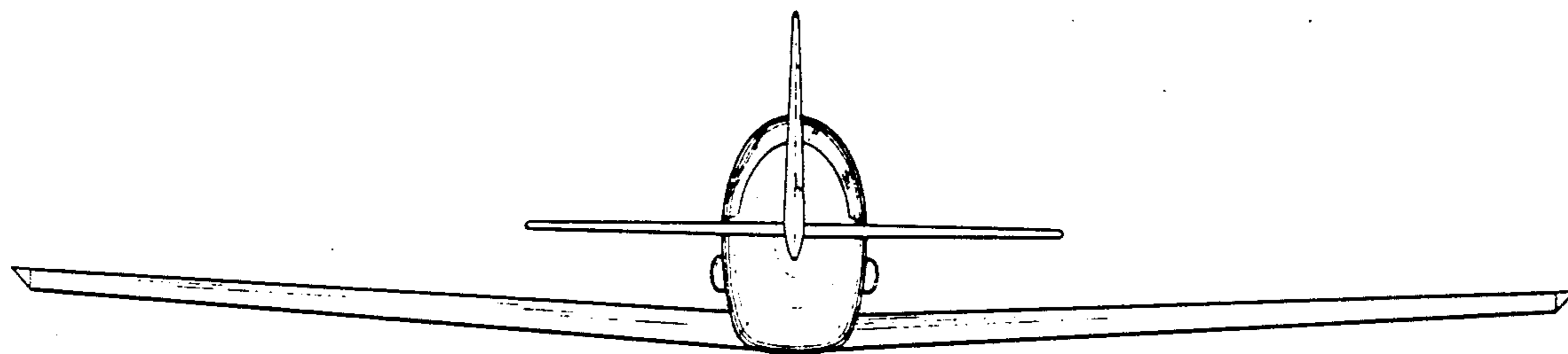

FIG 6