

[54] WHEEL SPIDER

Attorney, Agent, or Firm—Barnes & Thornburg

[75] Inventor: Stephen L. Gatsos, Indianapolis, Ind.

[57] CLAIM

[73] Assignee: Indus Wheel Company, Indianapolis, Ind.

The ornamental design for a wheel spider, as shown and described.

[\*\*] Term: 14 Years

DESCRIPTION

[21] Appl. No.: 766,549

FIG. 1 is a front elevational view of a wheel spider showing my new design, it being understood that the broken lines are for illustrative purposes only;

[22] Filed: Aug. 19, 1985

FIG. 2 is a right side elevational view thereof;

[52] U.S. Cl. .... D12/211

FIG. 3 is a cross-sectional view thereof taken along the line 3—3 of FIG. 1;

[58] Field of Search ..... D12/209, 211; 301/37 R, 301/63 R, 64 R, 64 SD, 65

FIG. 4 is a back elevational view thereof;

[56] References Cited

U.S. PATENT DOCUMENTS

- D. 215,652 10/1969 Griffith ..... D12/211
- D. 216,191 12/1969 Parker ..... D12/211
- D. 252,925 9/1979 Harty, Jr. .... D12/211
- D. 277,274 1/1985 Frazee et al. .... D12/211

FIG. 5 is a front elevational view of a wheel spider showing a second embodiment of my new design, it being understood that the broken lines are for illustrative purposes only;

FIG. 6 is a right side elevational view of FIG. 5;

FIG. 7 is a cross-sectional view taken along the line 7—7 of FIG. 5; and

FIG. 8 is a back elevational view of FIG. 5.

Primary Examiner—James M. Gandy

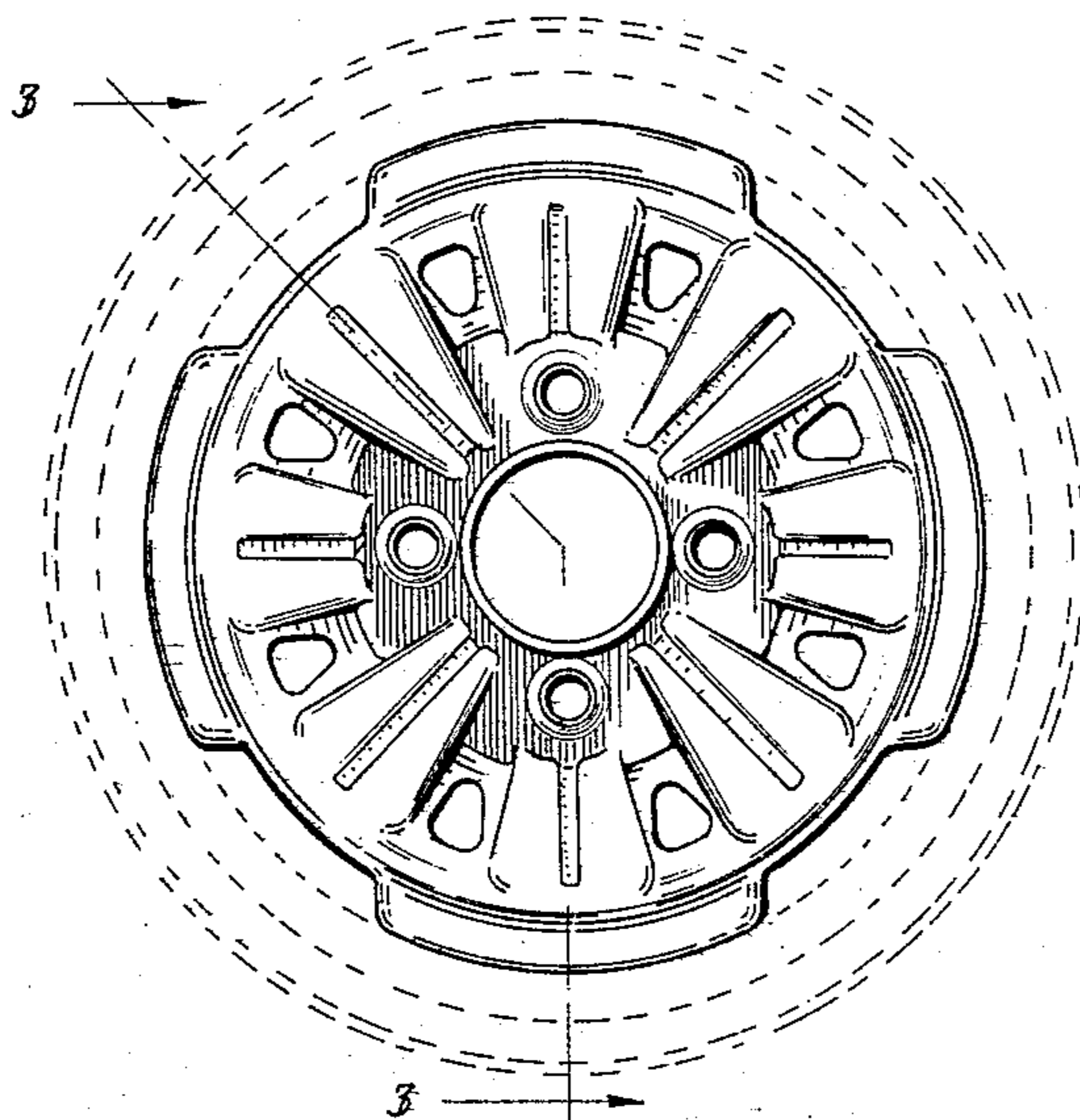

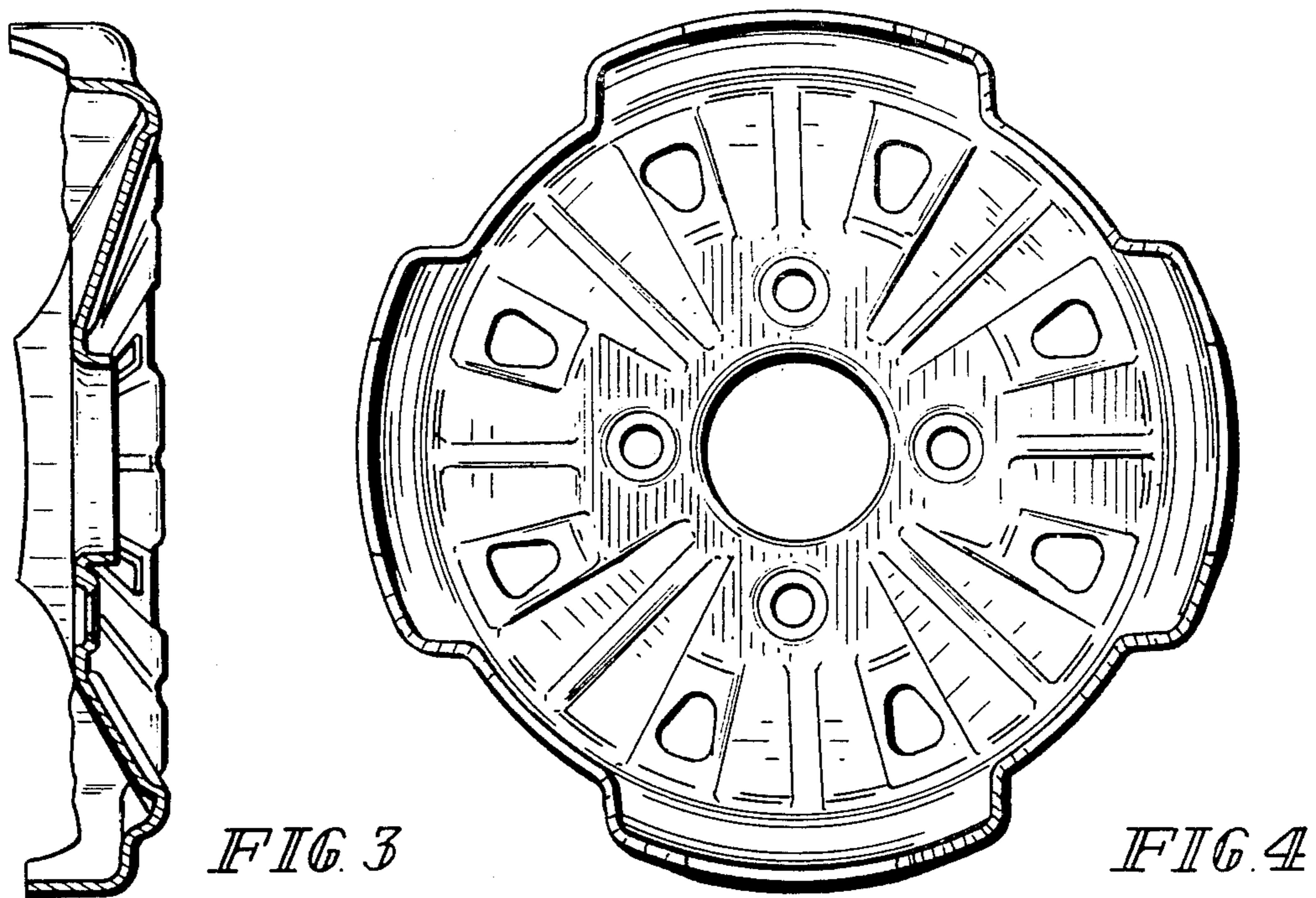
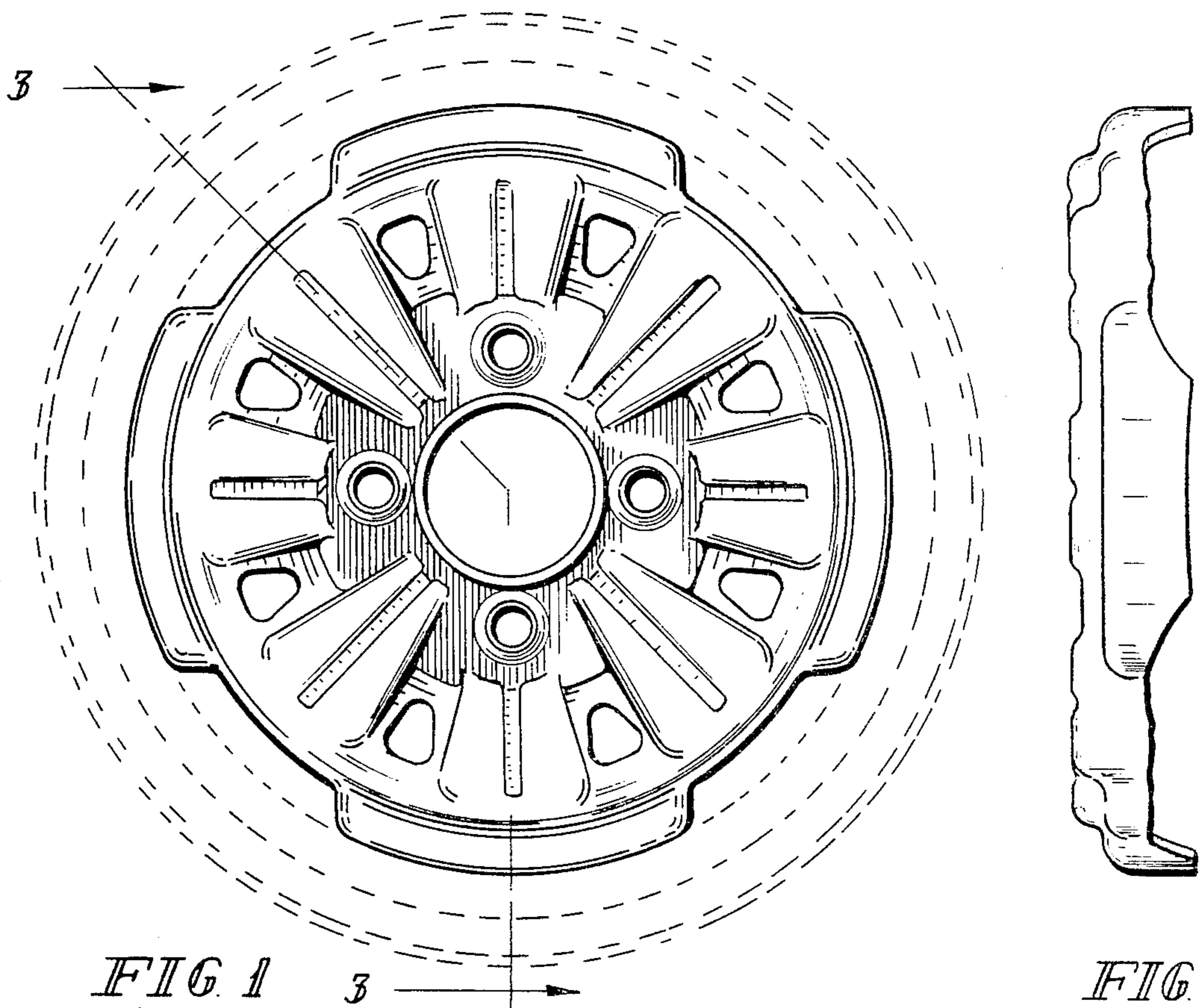



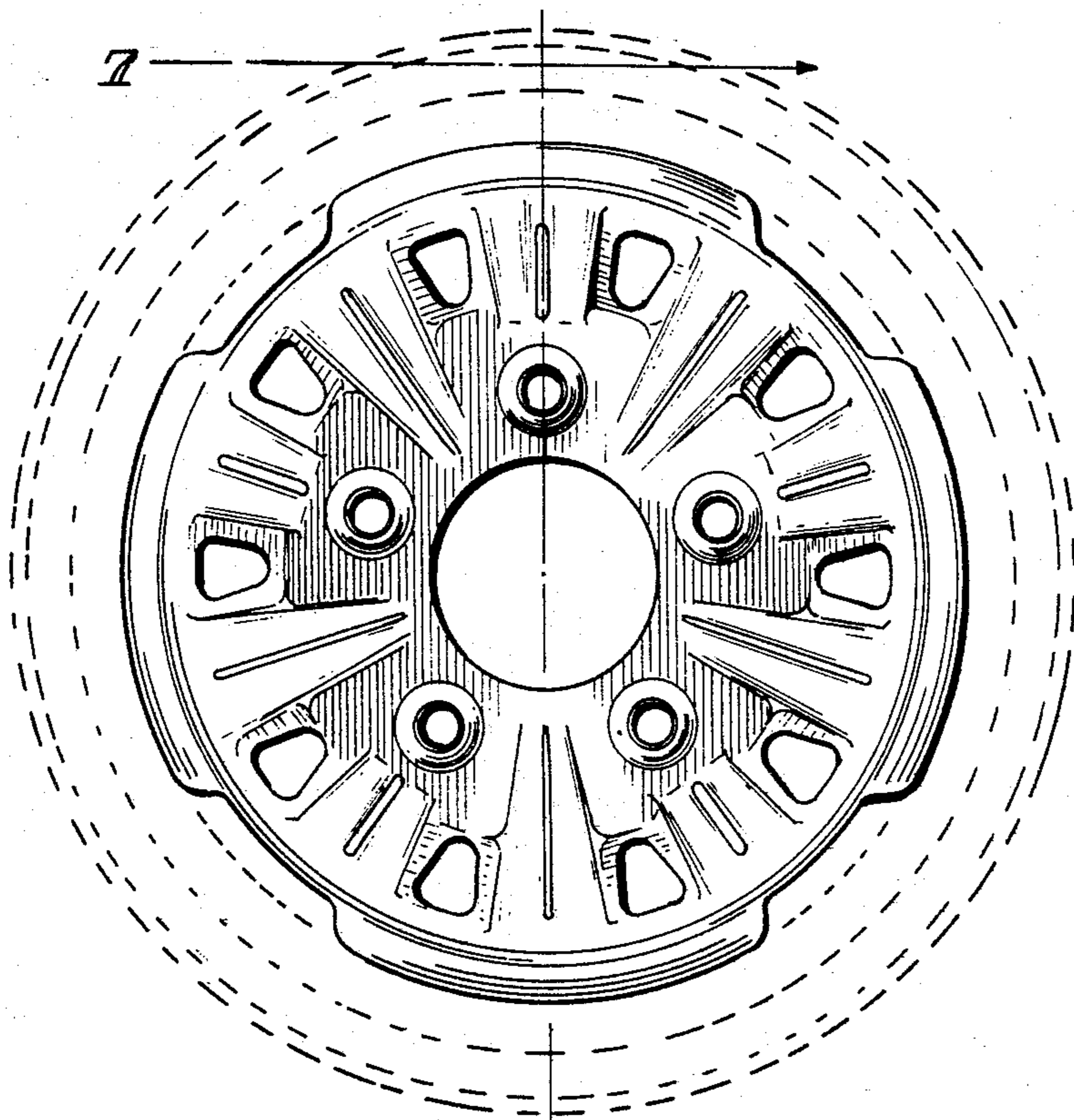

FIG. 5

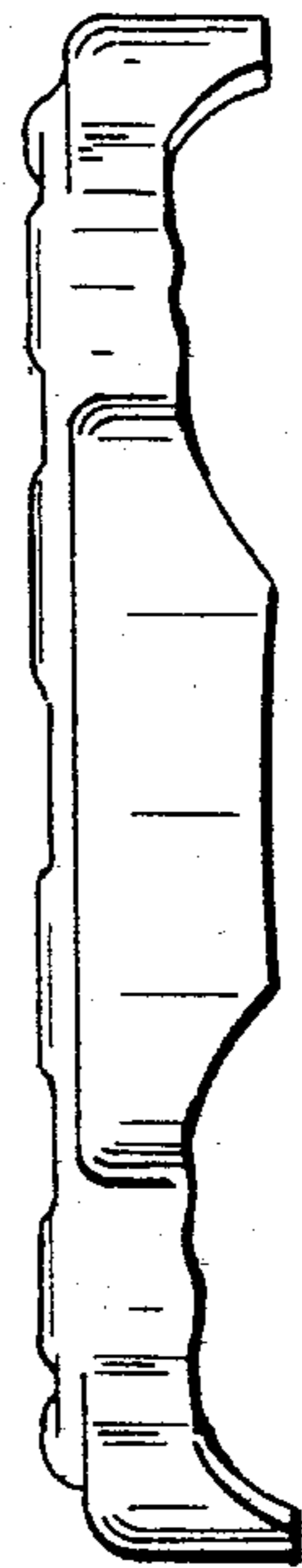

FIG. 6

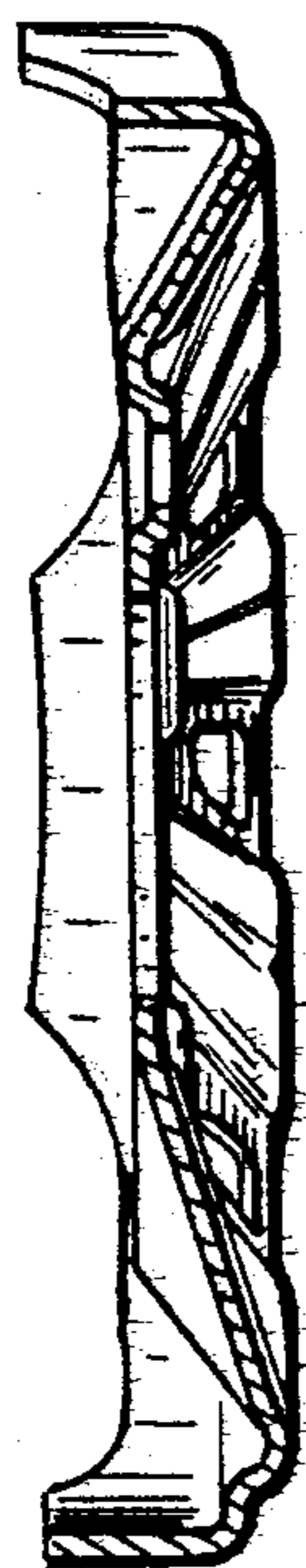

FIG. 7

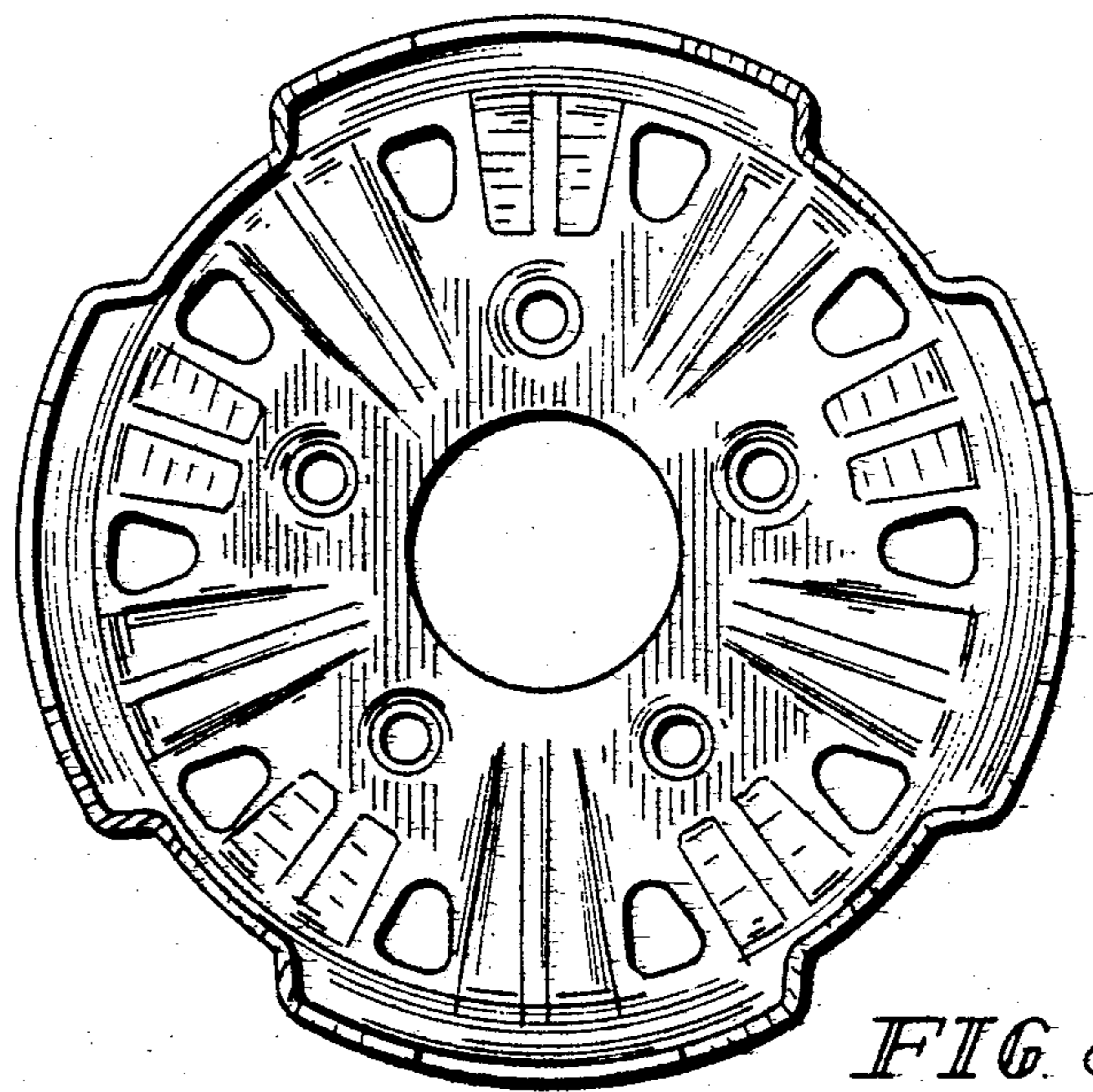

FIG. 8