

- [54] TRAVEL IRON
- [75] Inventor: Masao Tsuji, Old Lyme, Conn.
- [73] Assignee: North American Philips Corporation, New York, N.Y.
- [**] Term: 14 Years
- [21] Appl. No.: 833,452
- [22] Filed: Feb. 14, 1986

- 3,229,392 1/1966 Canilleri 38/90
- 3,672,080 6/1972 Murphy et al. 38/90

OTHER PUBLICATIONS

Sanyo Travel Iron Brochure-Jul. 1981.
 Hong Kong Enterprises-9/1983—p. 194-Indicator
 Travel Irons; p. 253-Travel Iron.

Primary Examiner—Catherine E. Kemper
 Attorney, Agent, or Firm—Thomas A. Briody; William
 J. Streeter; Rolf E. Schneider

Related U.S. Application Data

- [63] Continuation-in-part of Ser. No. 663,604, Oct. 22, 1984,
 Pat. No. Des. 283,934.
- [52] U.S. Cl. D32/69
- [58] Field of Search D32/68-73;
 38/69, 74, 75, 77.1-77.9; 88, 94, 96, 142;
 219/245-259, 271-276

[57] CLAIM

The ornamental design for a travel iron, as shown and
 described.

DESCRIPTION

FIG. 1 is a top plan view of a travel iron showing my
 new design, the handle being in its upright position;
 FIG. 2 is a right-side elevational view thereof;
 FIG. 3 is a bottom plan view thereof;
 FIG. 4 is a left-side elevational view thereof;
 FIG. 5 is a front elevational view thereof;
 FIG. 6 is a rear elevational view thereof;
 FIG. 7 is a top plan view of the travel iron, with the
 handle in its folded position;
 FIG. 8 is a right-side elevational view of FIG. 7;
 FIG. 9 is a left-side elevational view of FIG. 7;
 FIG. 10 is a bottom plan view of FIG. 7;
 FIG. 11 is a front elevational view of FIG. 7; and
 FIG. 12 is a rear elevational view of FIG. 7.

[56] References Cited

U.S. PATENT DOCUMENTS

- D. 174,593 4/1955 Pickard et al. D32/69
- D. 216,153 11/1969 Tsunoda D32/70
- D. 240,997 8/1976 Fulkenbeck D32/70
- D. 275,042 8/1984 Stowell et al. D32/70
- D. 279,416 6/1985 Chan D32/69
- 2,763,075 9/1956 Vance 38/77.4 X
- 2,769,257 11/1956 Duncanson et al. D32/70 X
- 2,786,287 3/1957 Swann 38/77.4
- 3,184,871 5/1965 D'Alessandro 38/77.28

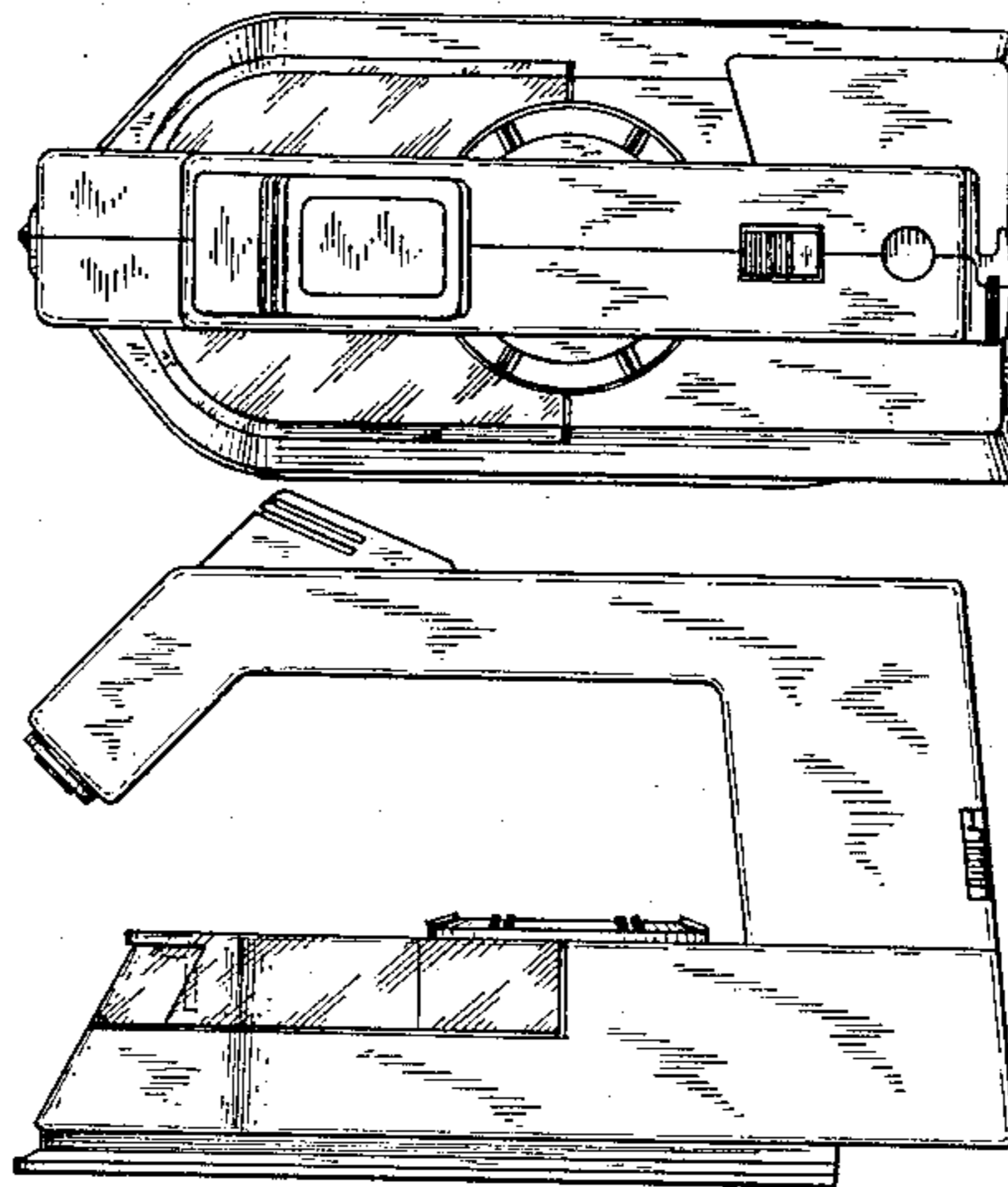

FIG. 1

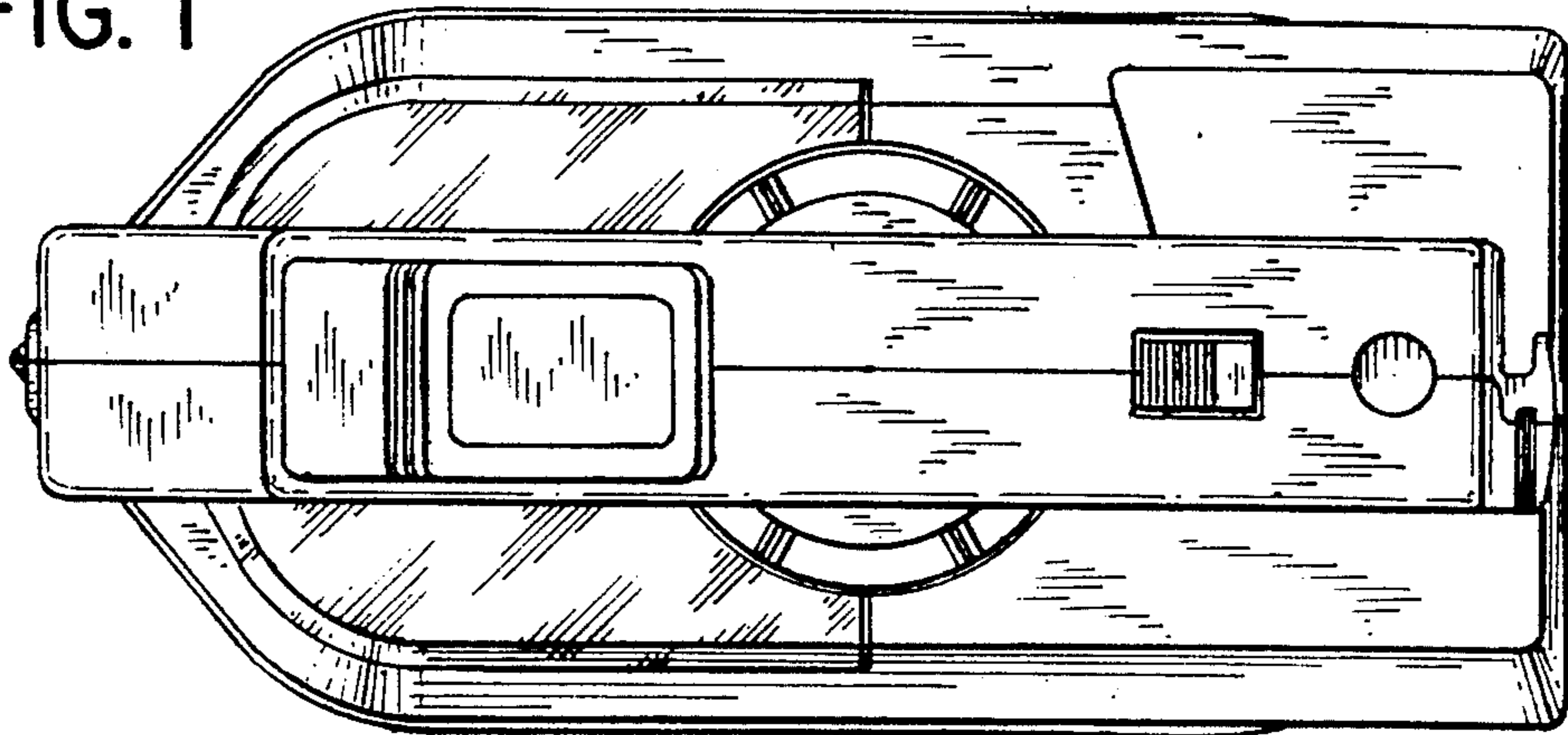

FIG. 2

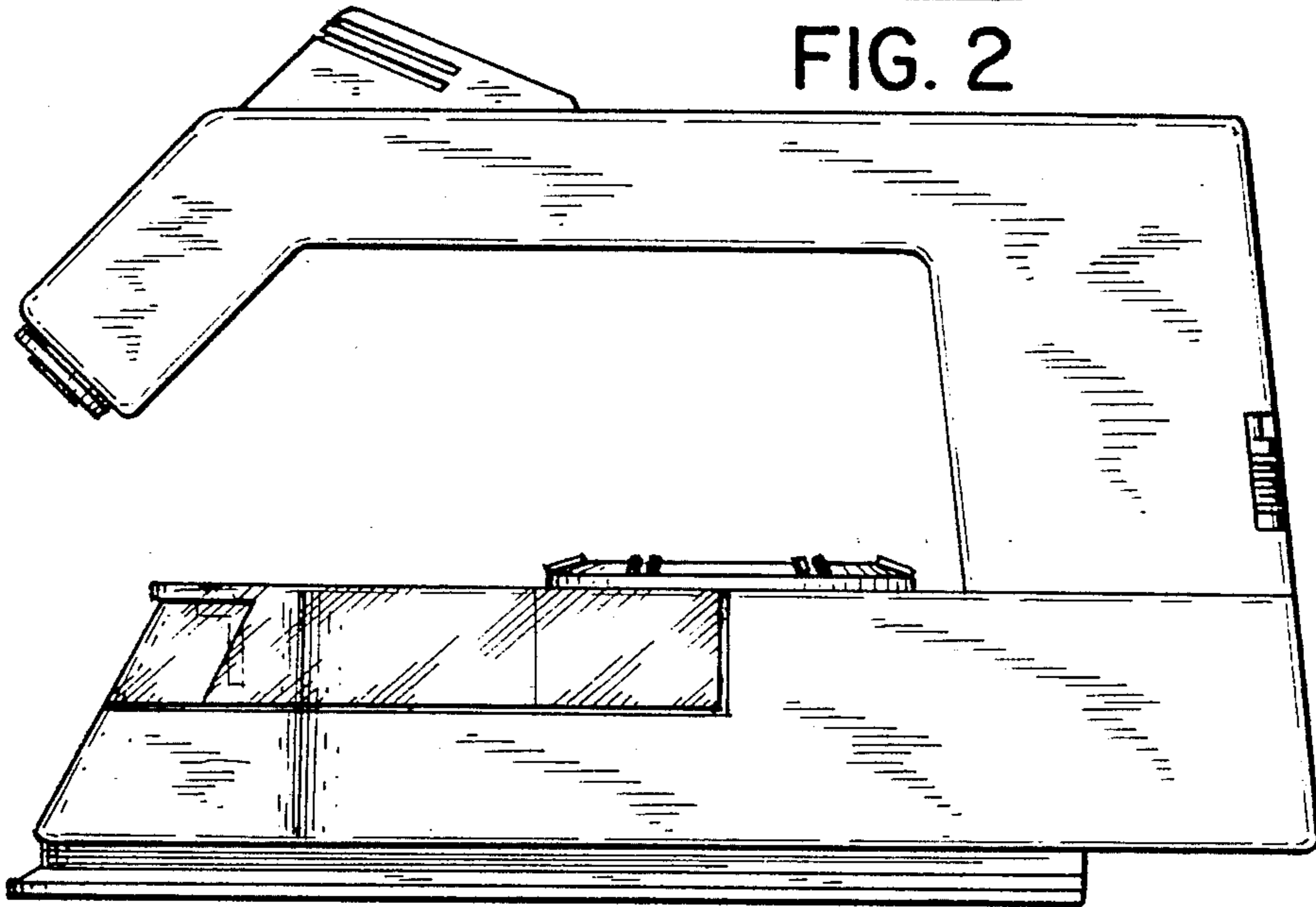

FIG. 3

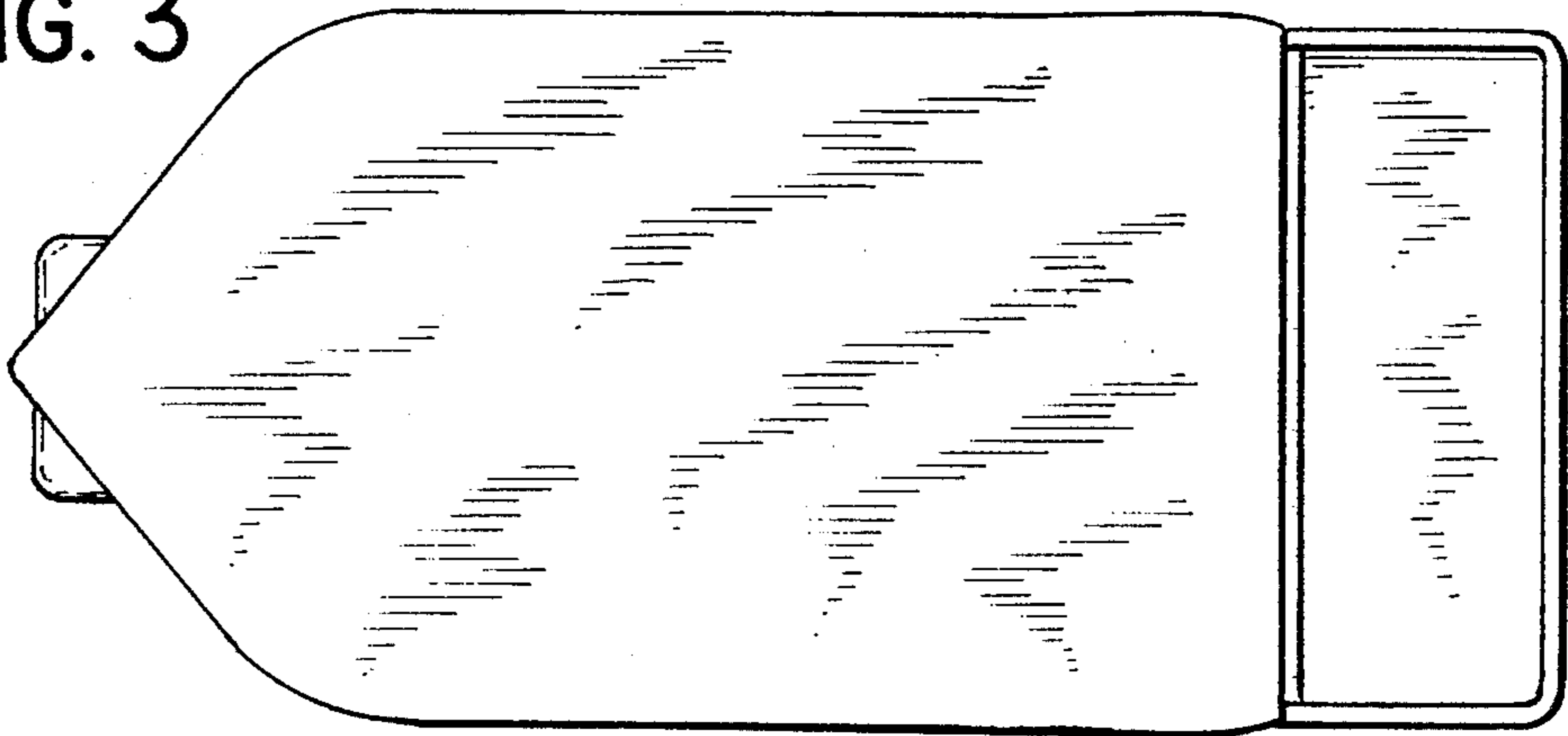

FIG. 4

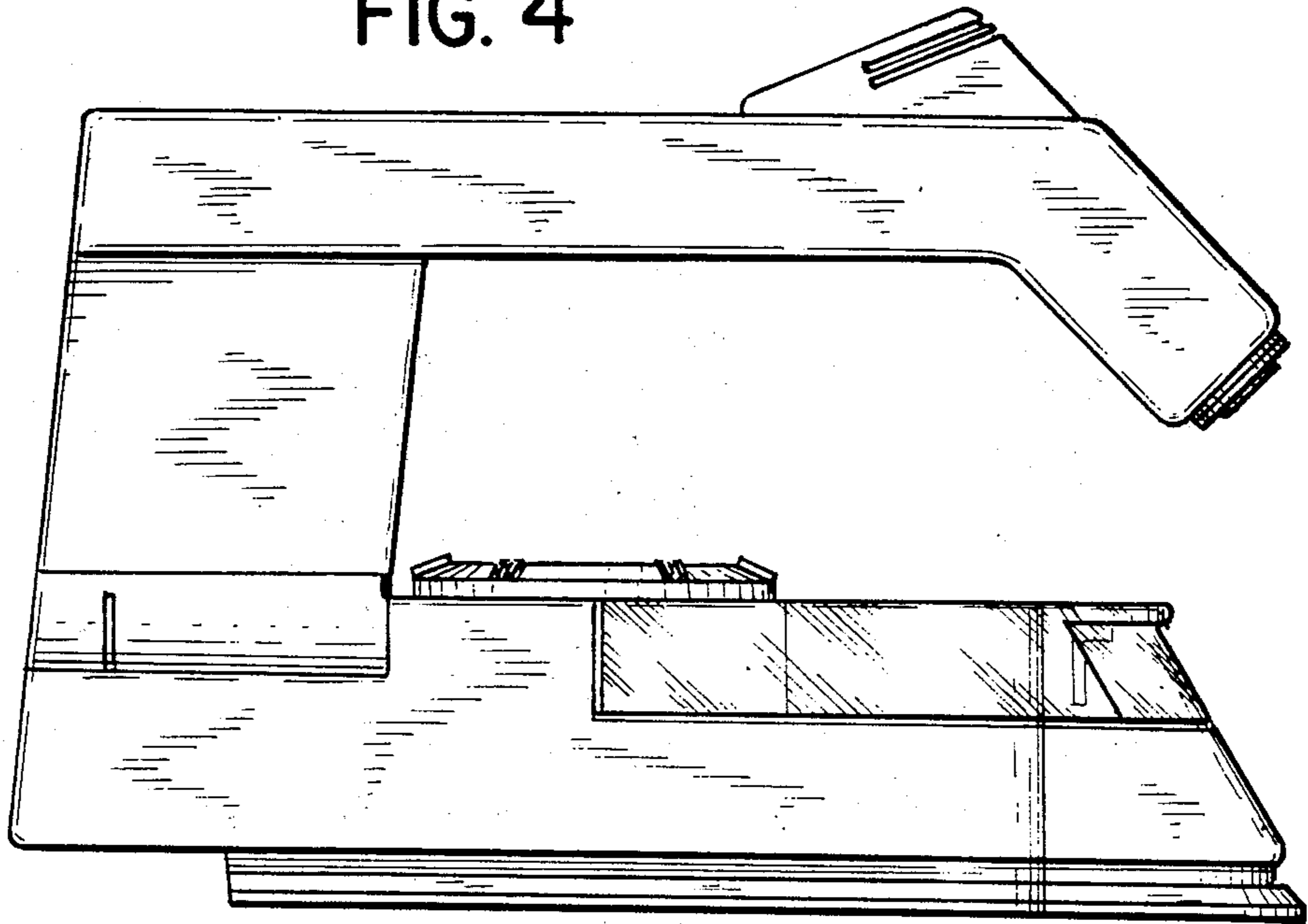

FIG. 5

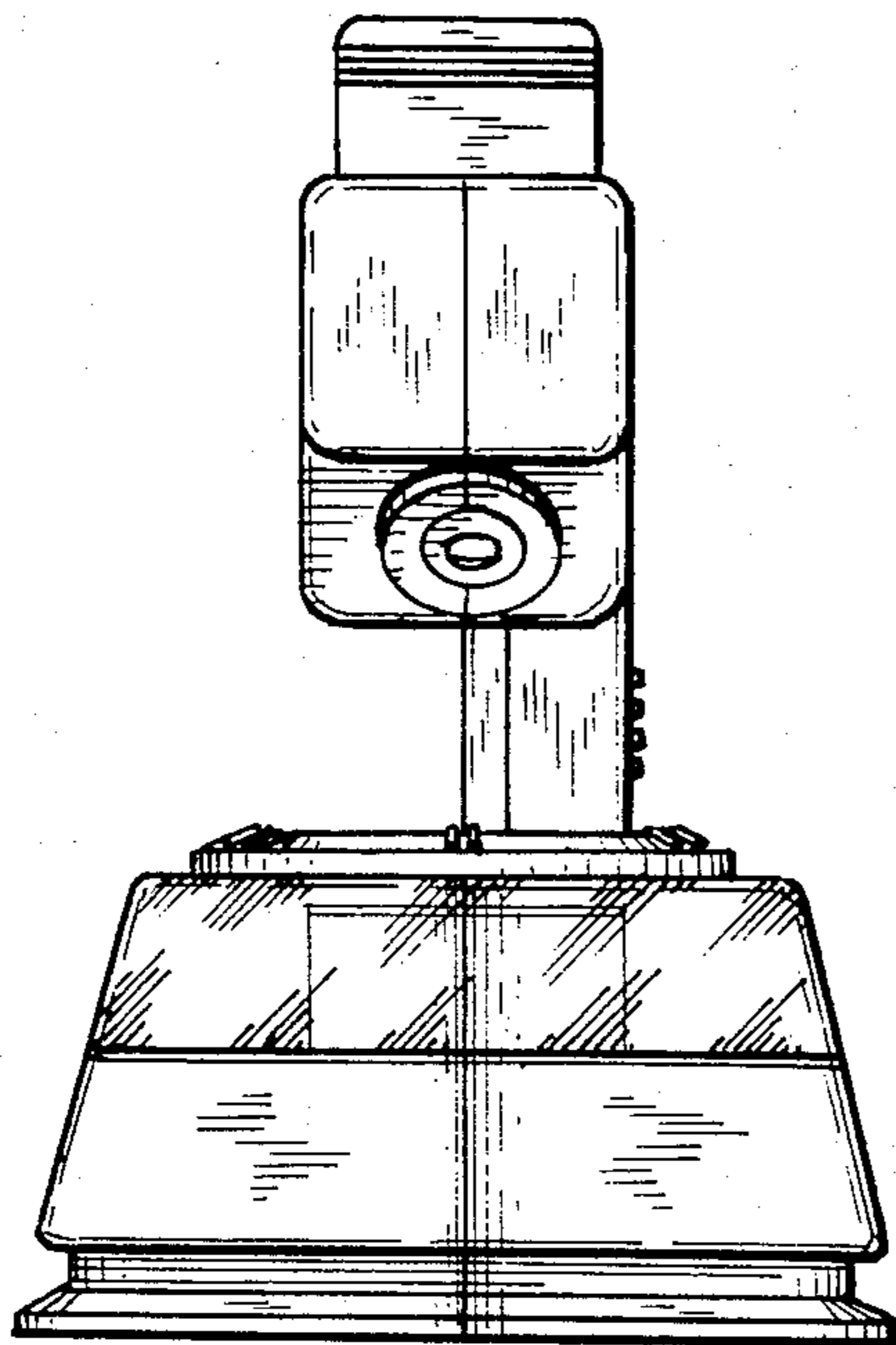

FIG. 6

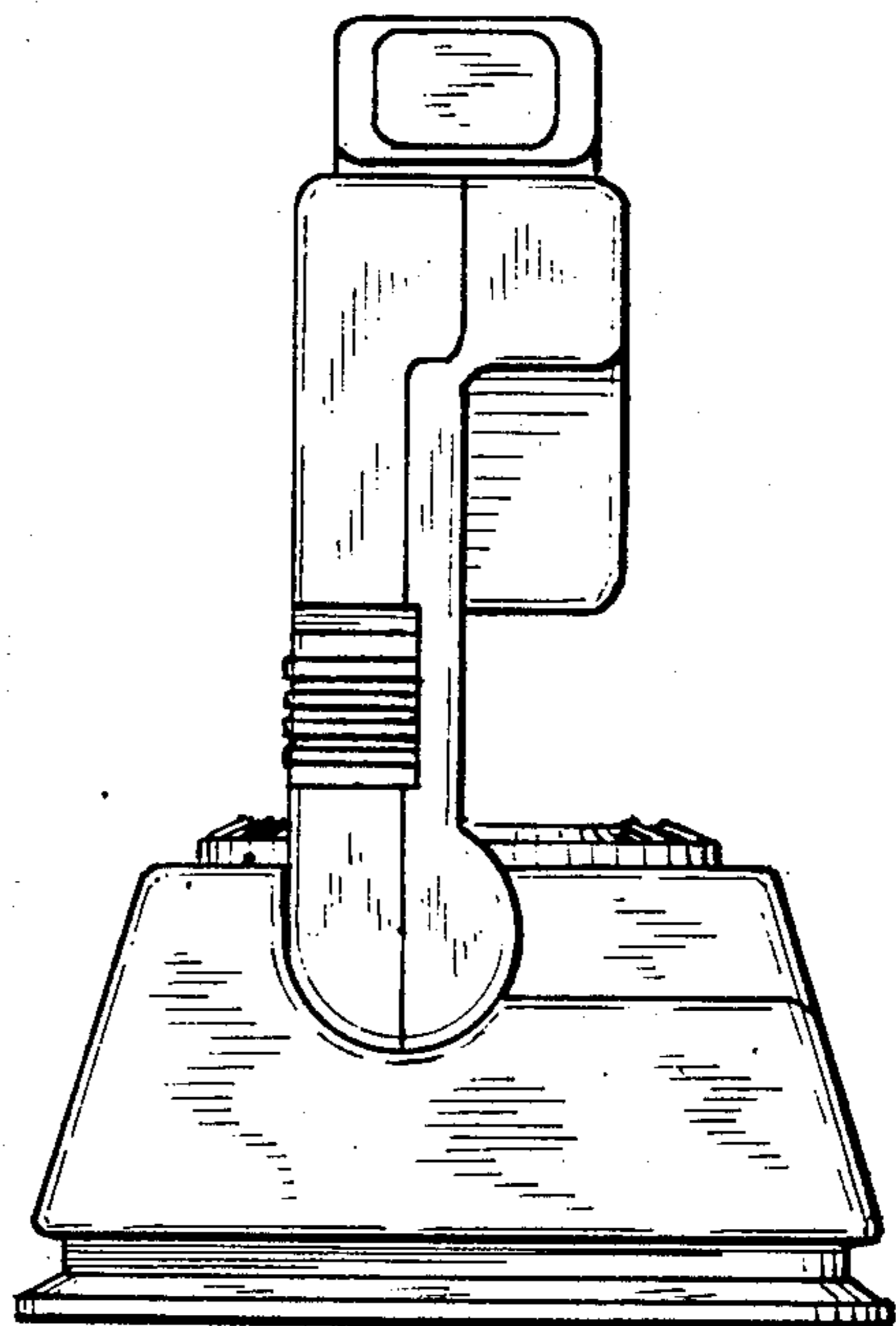

FIG. 7

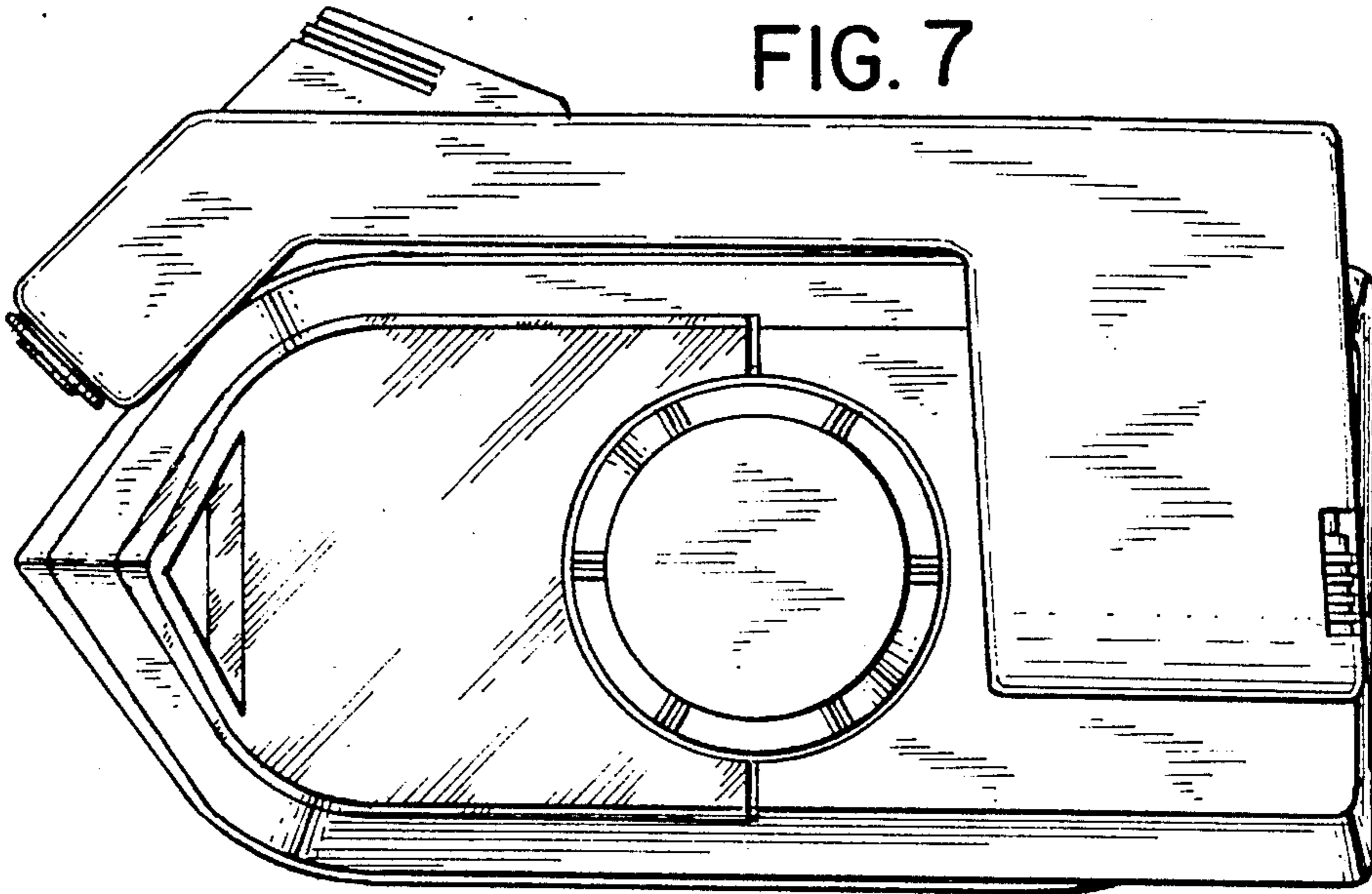

FIG. 8

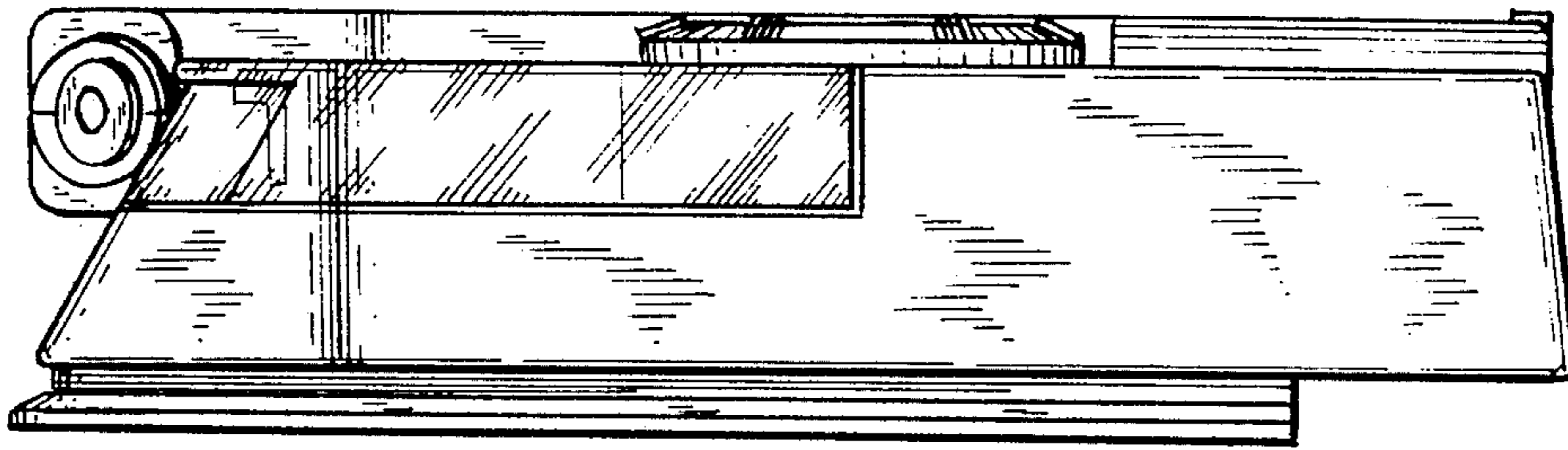

FIG. 9

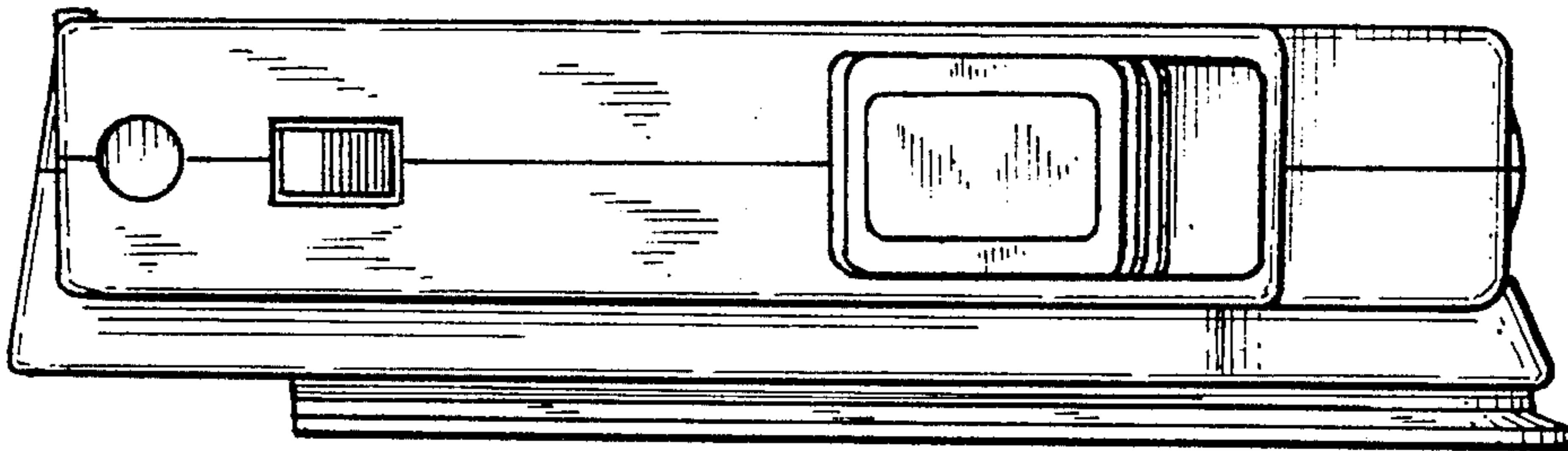

FIG. 10

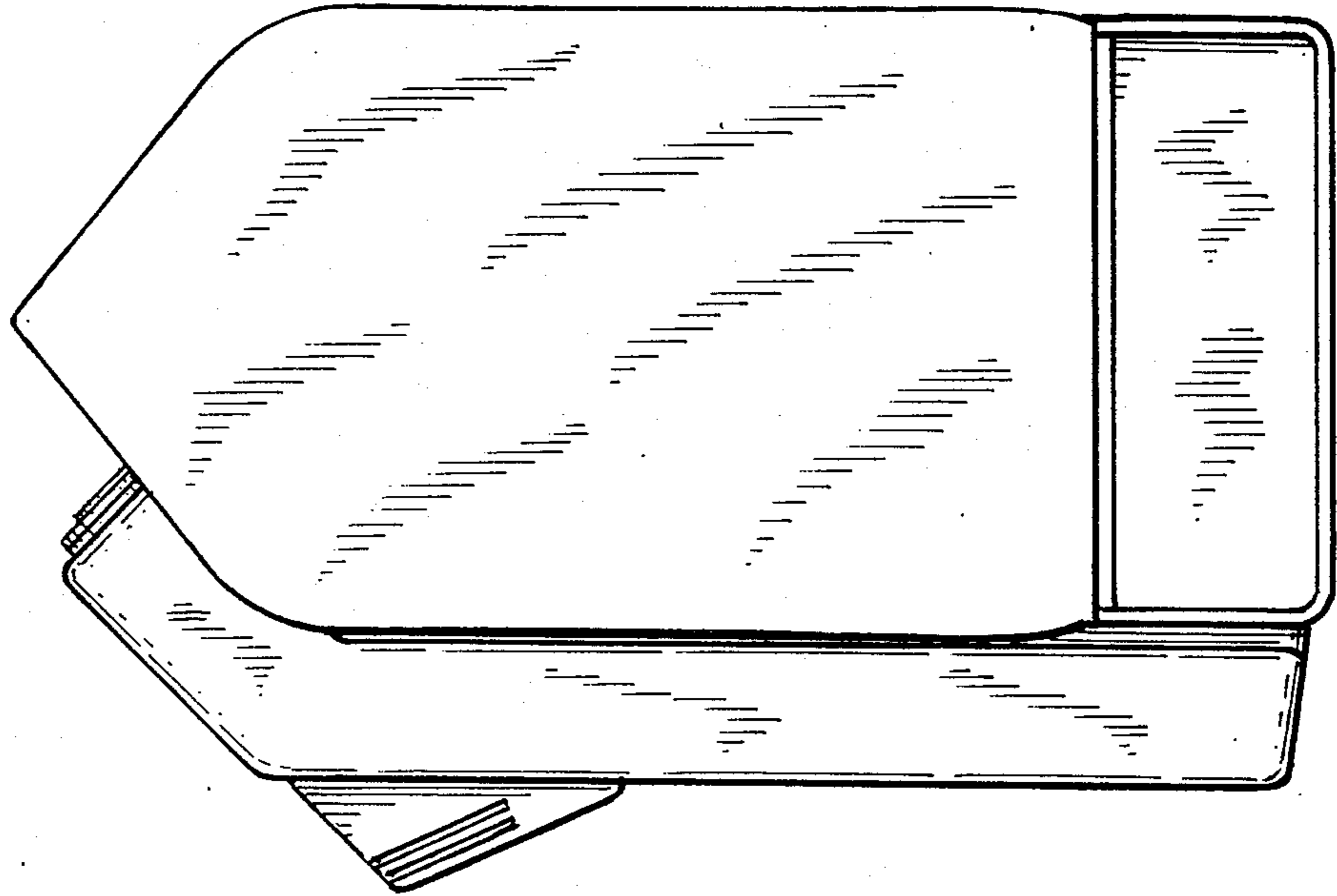

FIG. 11

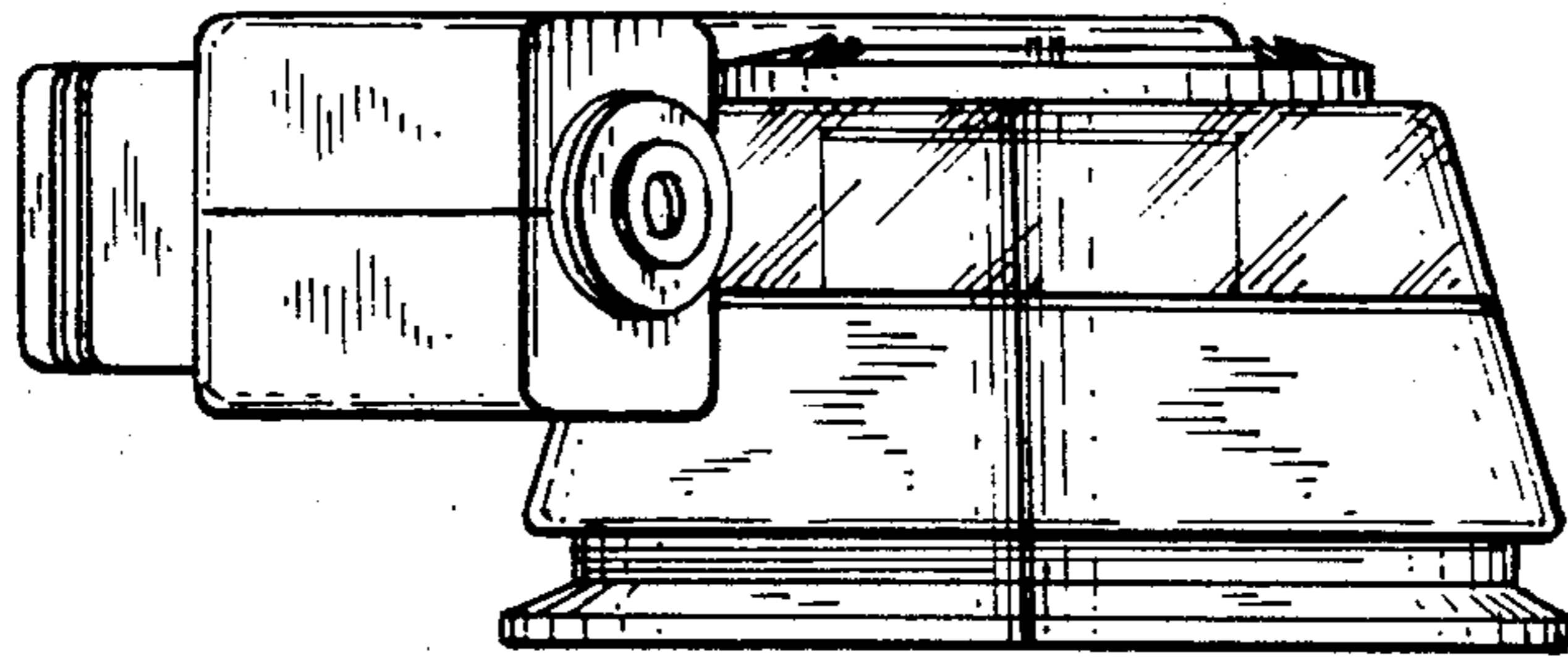

FIG. 12

