

[54] VEHICLE WHEEL CENTER

[75] Inventor: Donald J. Reid, Plymouth, Mich.

[73] Assignee: Kelsey-Hayes Company, Romulus, Mich.

[\*\*] Term: 14 Years

[21] Appf. No.: 764,824

[22] Filed: Aug. 12, 1985

[52] U.S. Cl. .... D12/211

[58] Field of Search ..... D12/206, 209, 211; 301/37 R, 63 R, 64 R, 64 SD, 65

[56] References Cited

U.S. PATENT DOCUMENTS

- D. 198,207 5/1964 Butler et al. .... D12/211
- D. 272,431 1/1984 Hedlund ..... D12/211
- D. 272,897 3/1984 Chapman ..... D12/211

Primary Examiner—James M. Gandy

Attorney, Agent, or Firm—Ralph J. Skinkiss; David L. Kuhn

[57] CLAIM

The ornamental design for a vehicle wheel center, as shown and described.

DESCRIPTION

FIG. 1 is a front elevational view of a vehicle wheel center showing my new design.

FIG. 2 is a sectional view taken along line 2—2 in FIG. 1.

FIG. 3 is a sectional view taken along line 3—3 in FIG. 1.

FIG. 4 is a sectional view taken along line 4—4 in FIG. 1.

FIG. 5 is a sectional view taken along line 5—5 in FIG. 1.

FIG. 6 is a sectional view taken along line 6—6 in FIG. 1.

The broken lines in the drawing are for illustrative purposes only and form no part of the claimed design.

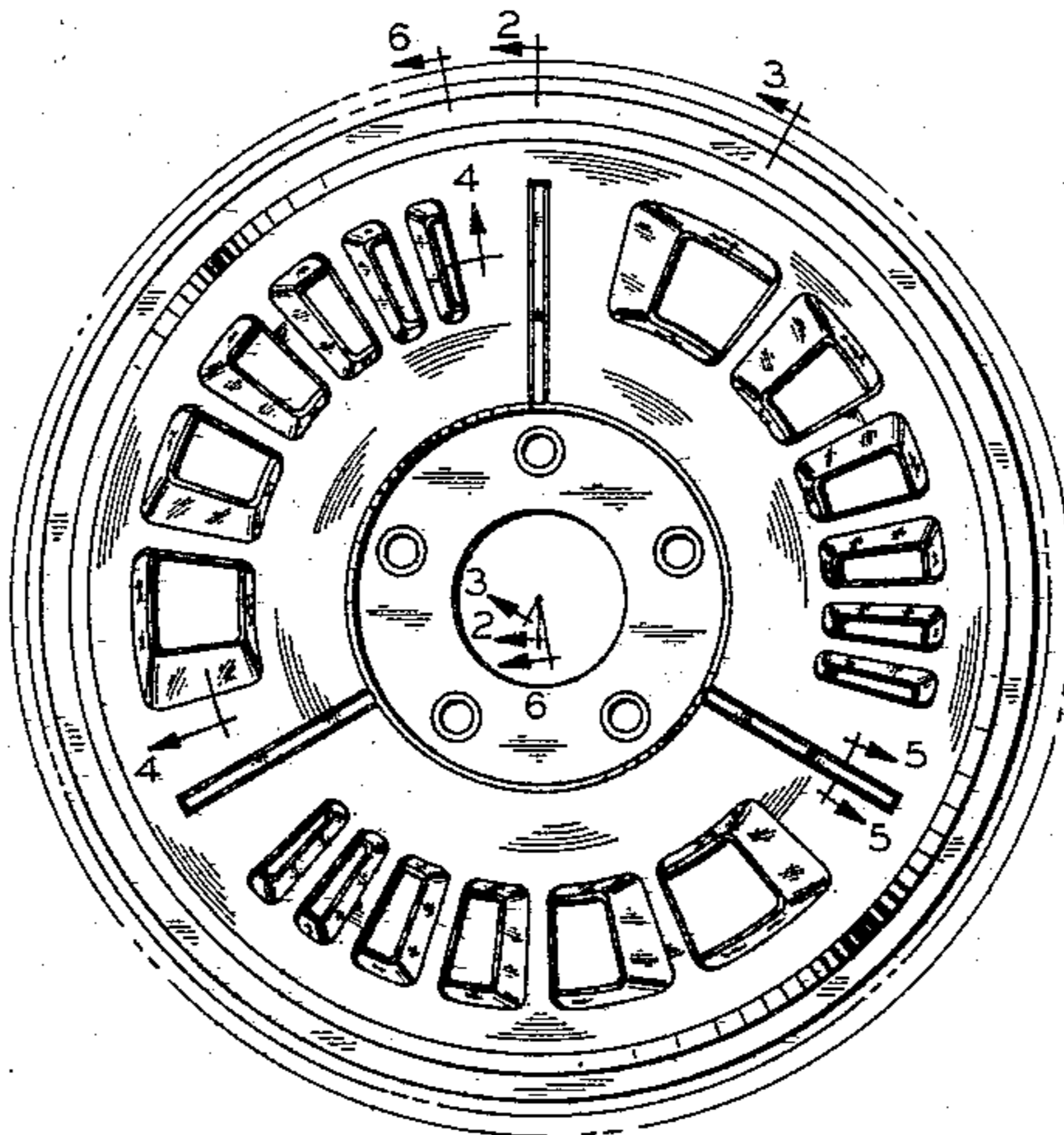

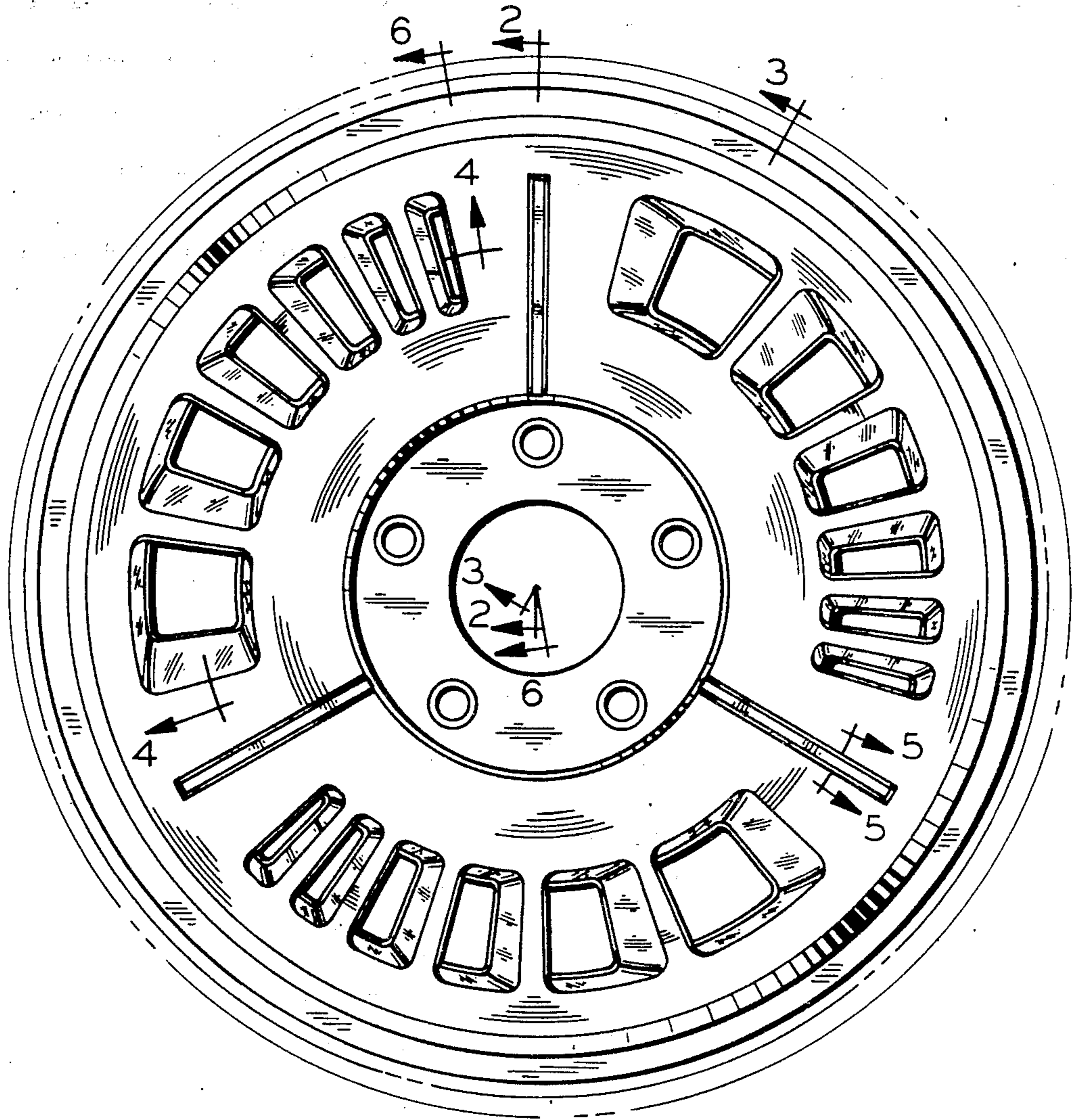

—FIG. 1

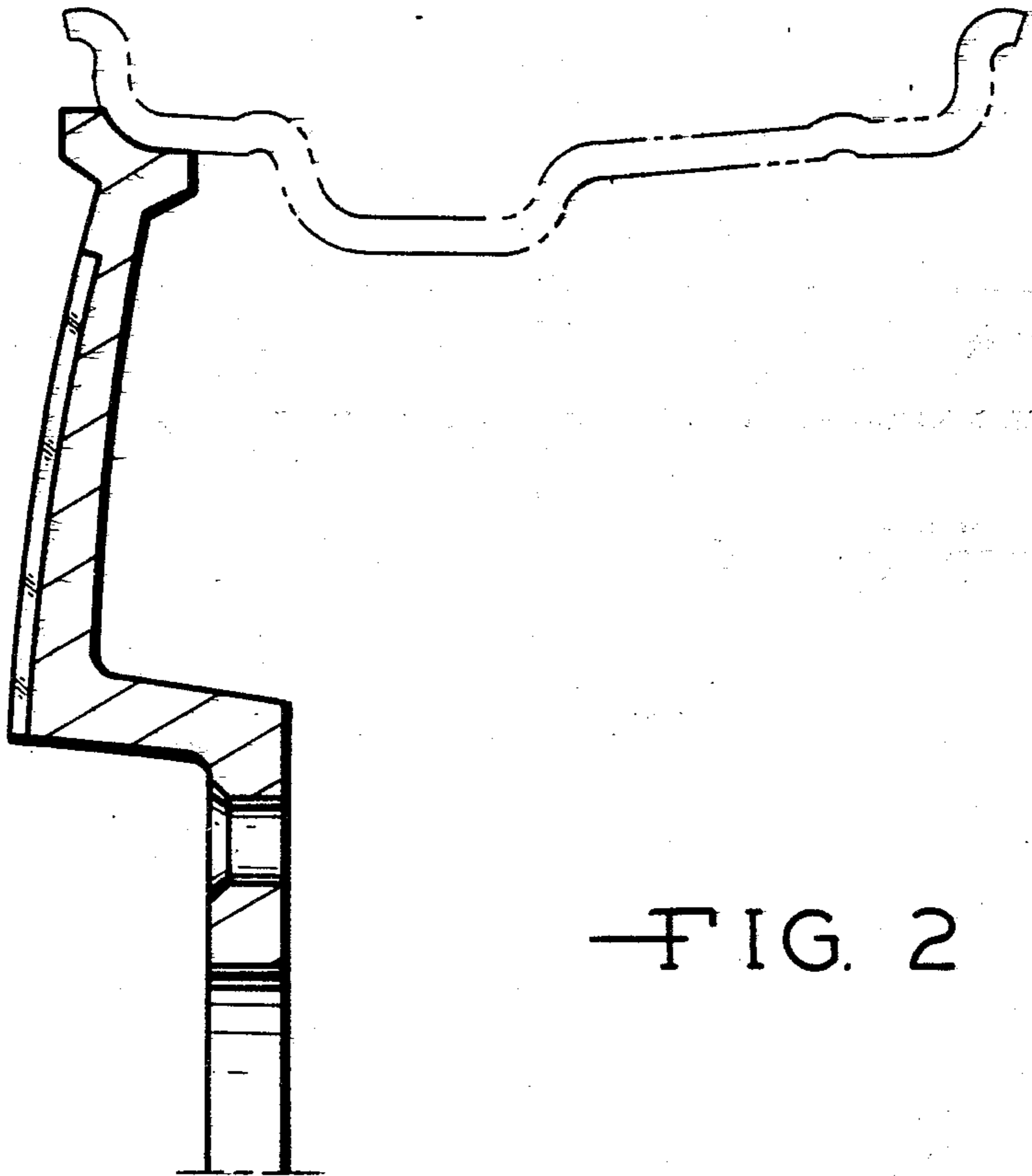

FIG. 2

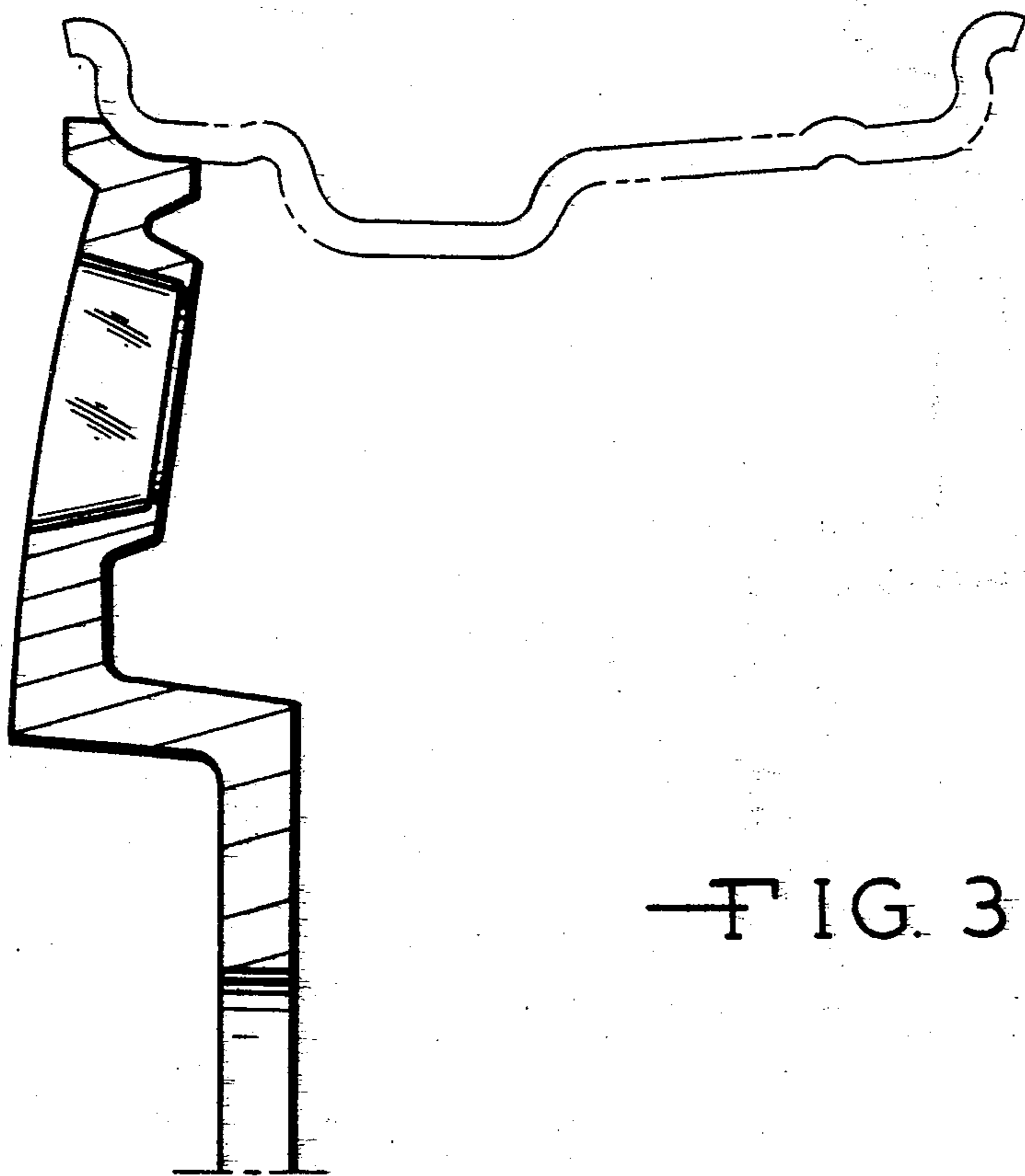
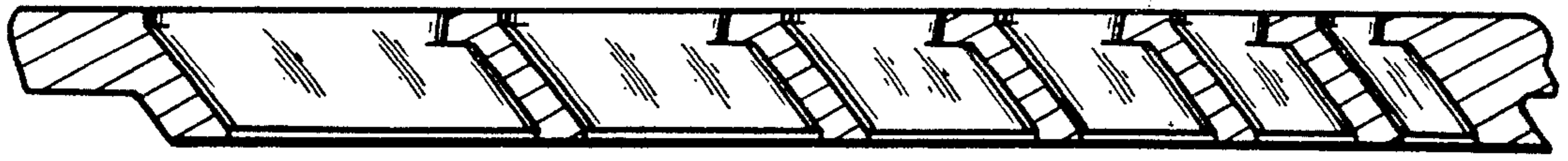

FIG. 3



—FIG. 4



—FIG. 5

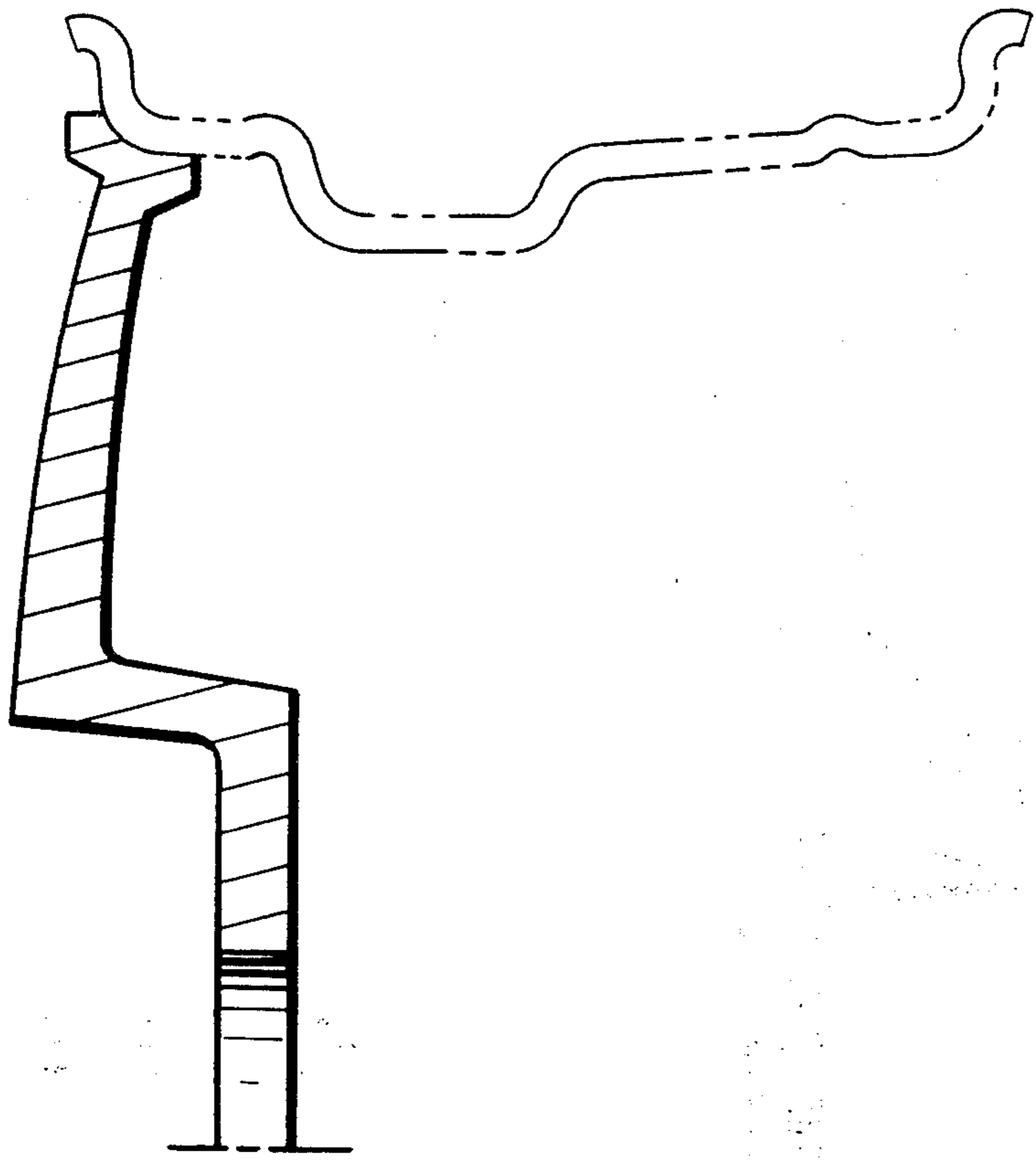

—FIG. 6