

[54] BICYCLE REAR DERAILLEUR

[75] Inventor: Henri Juy, Dijon, France

[73] Assignee: Etablissements le Simplex, France

[**] Term: 14 Years

[21] Appl. No.: 608,559

[22] Filed: May 9, 1984

[30] Foreign Application Priority Data

Sep. 11, 1983 [FR] France 83157

[52] U.S. Cl. D12/124

[58] Field of Search D12/124; 474/82

[56] References Cited

PUBLICATIONS

American Bicyclist & Motorcyclist, 7/82, p. 5, Campagnolo "980" Derailleur, bottom right side of page.

American Bicyclist & Motorcyclist, 8/82, p. 27,

Shimano RS/Steel Centeron Derailleur, center left side of page.

Primary Examiner—James M. Gandy
Attorney, Agent, or Firm—Eric P. Schellin

[57] CLAIM

The ornamental design for a bicycle rear derailleur, as shown.

DESCRIPTION

FIG. 1 is a side elevation view of a bicycle rear derailleur showing my new design;

FIG. 2 is a bottom plan view thereof;

FIG. 3 is a top plan view thereof;

FIG. 4 is a side elevation view thereof opposite to that shown in FIG. 1;

FIG. 5 is an end elevation view thereof; and

FIG. 6 is an opposite end elevation view thereof.

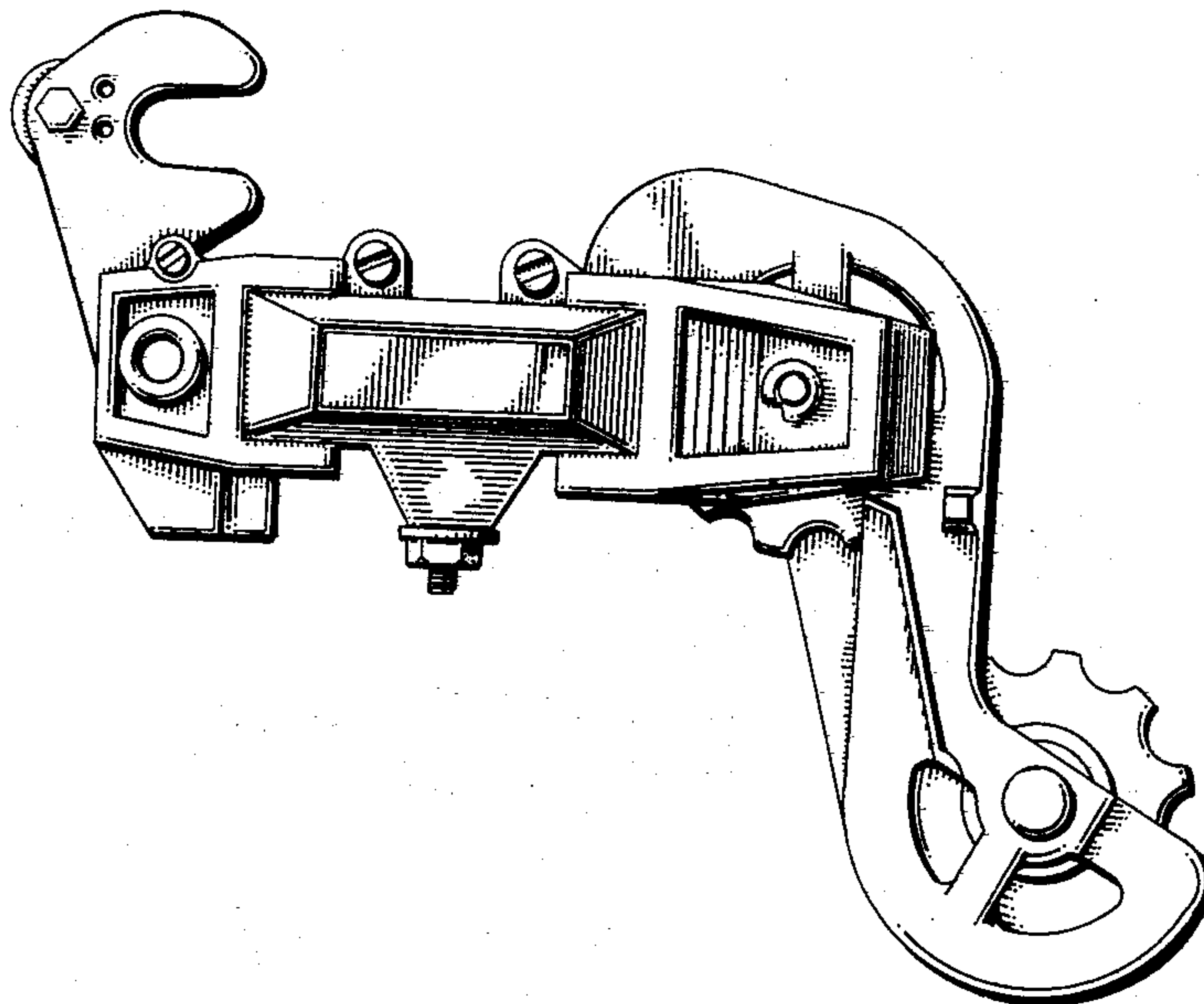

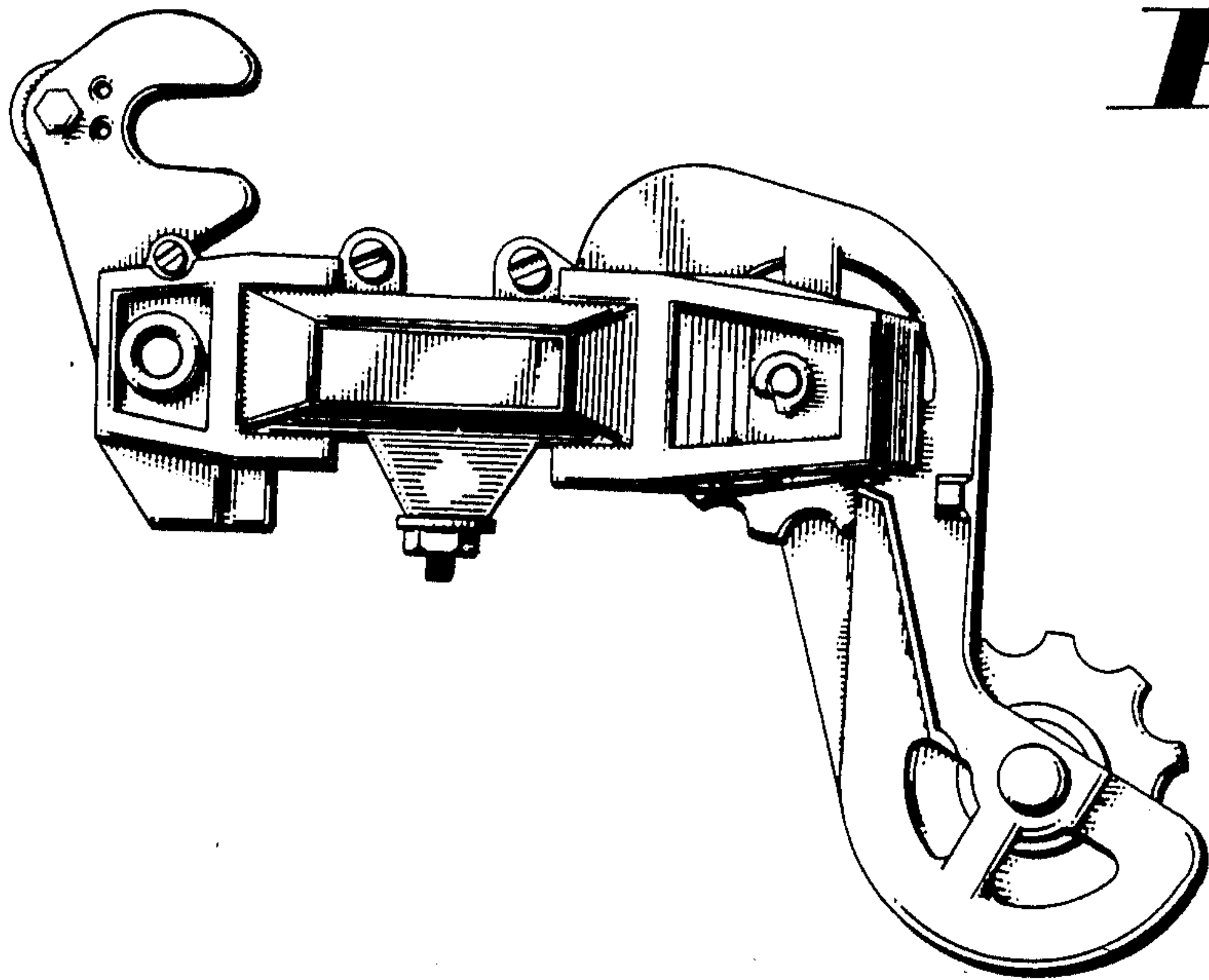

Fig. 1

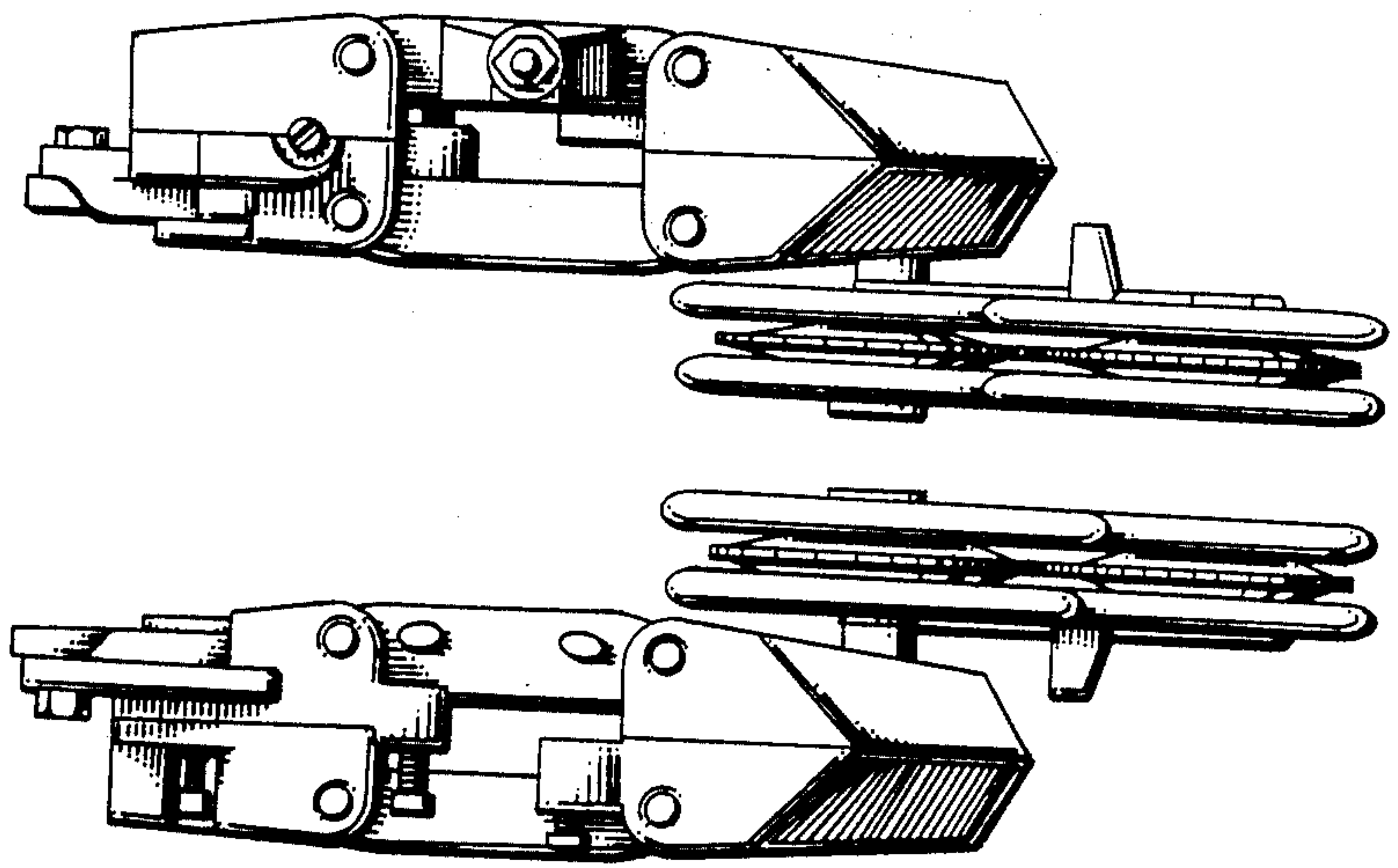

Fig. 2

Fig. 3

Fig. 4

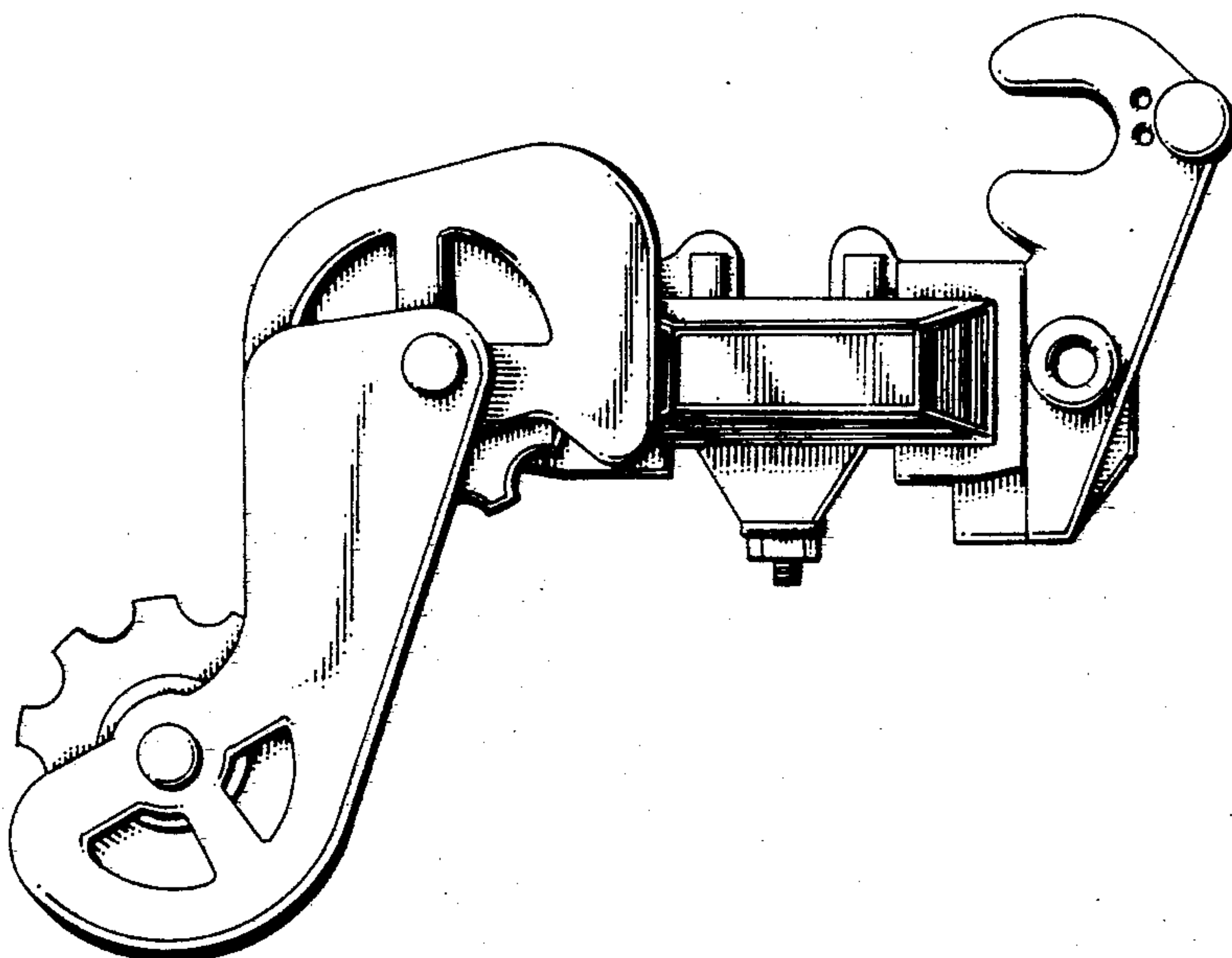

Fig. 5

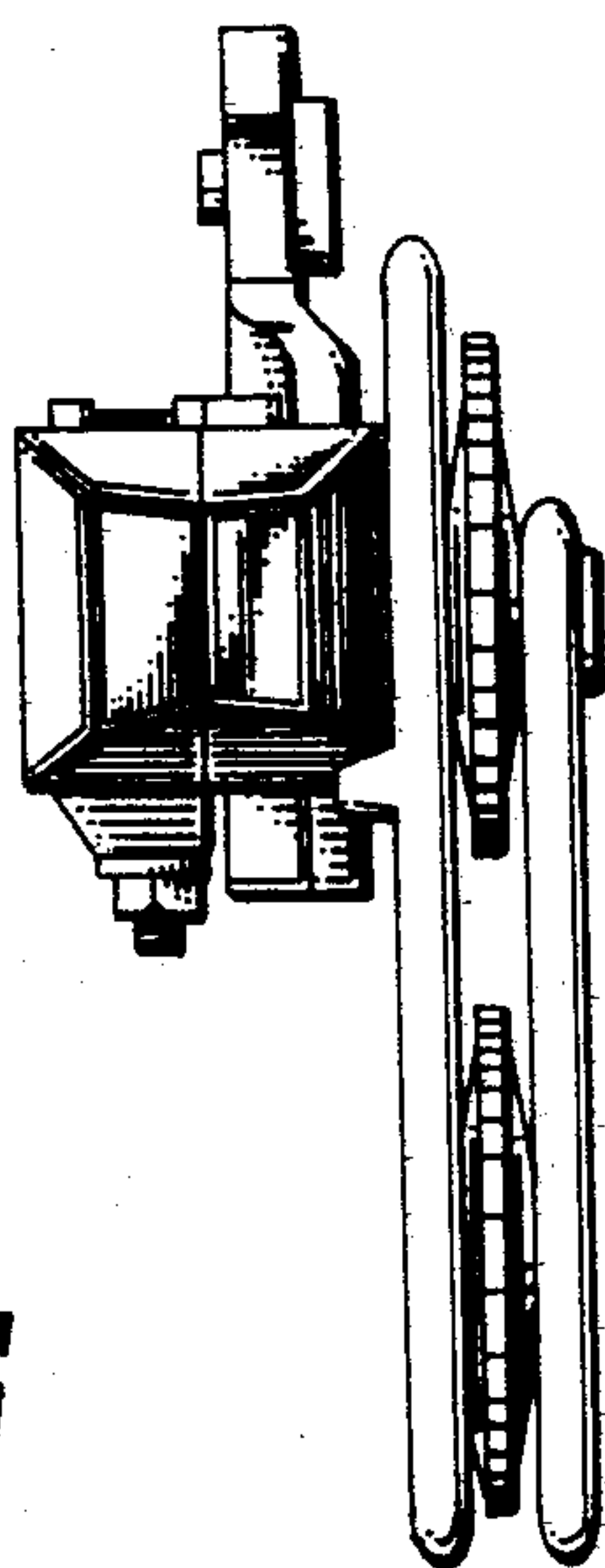

Fig. 6

