

[54] BOAT LEVELER TRIM TAB

[75] Inventors: Lawrence P. Zepp, Toledo, Ohio; Christopher C. Dowdey, Grosse Ile, Mich.; Robert B. Riggs, Ypsilanti, Mich.; D. Mark Trostle, Canton, Mich.

[73] Assignee: International Hydraulic Systems, Inc., Southgate, Mich.

[\*\*] Term: 14 Years

[21] Appl. No.: 638,293

[22] Filed: Aug. 6, 1984

[52] U.S. Cl. .... D12/317

[58] Field of Search ..... D12/317, 318; 114/285, 114/286, 287

[56] References Cited

U.S. PATENT DOCUMENTS

D. 235,635	7/1975	Curtis .....	D12/317
D, 253,999	1/1980	Richards et al. ....	D12/317
3,062,167	11/1962	Bennett .....	114/66.5
3,111,103	11/1963	Bennett .....	114/66.5
3,200,782	8/1965	Walden et al. ....	114/285
3,326,164	6/1967	Kercheval .....	114/66.5
3,399,643	9/1968	Bennett .....	114/66.5
3,463,109	8/1969	Weiler .....	114/286
3,468,278	9/1969	Kercheval .....	114/66.5
3,589,323	6/1971	Kercheval .....	114/66.5

3,628,487	12/1971	Bennett .....	114/66.5
3,695,204	10/1972	Bennett .....	114/66.5
3,814,044	6/1974	Kercheval .....	114/66.5
4,261,278	4/1981	Gaudin .....	114/286

Primary Examiner—James M. Gandy  
Assistant Examiner—Kay. H. Chin  
Attorney, Agent, or Firm—Cullen, Sloman, Cantor, Grauer, Scott, & Rutherford

[57] CLAIM

The ornamental design for a boat leveler trim tab, as shown and described.

DESCRIPTION

FIG. 1 is a perspective view of a boat leveler trim tab showing our new design, the broken lines being for illustrative purposes only and form no part of the claimed design;  
FIG. 2 is a top plan view thereof;  
FIG. 3 is a front elevation view thereof;  
FIG. 4 is a bottom plan view thereof;  
FIG. 5 is a rear elevation view thereof;  
FIG. 6 is a side elevational view thereof;  
FIG. 7 is a fragmentary sectional view thereof taken along line 7—7 in FIG. 2;  
FIG. 8 is a fragmentary sectional view thereof taken along line 8—8 in FIG. 2; and  
FIG. 9 is a cross-sectional view thereof taken along line 9—9 in FIG. 2.

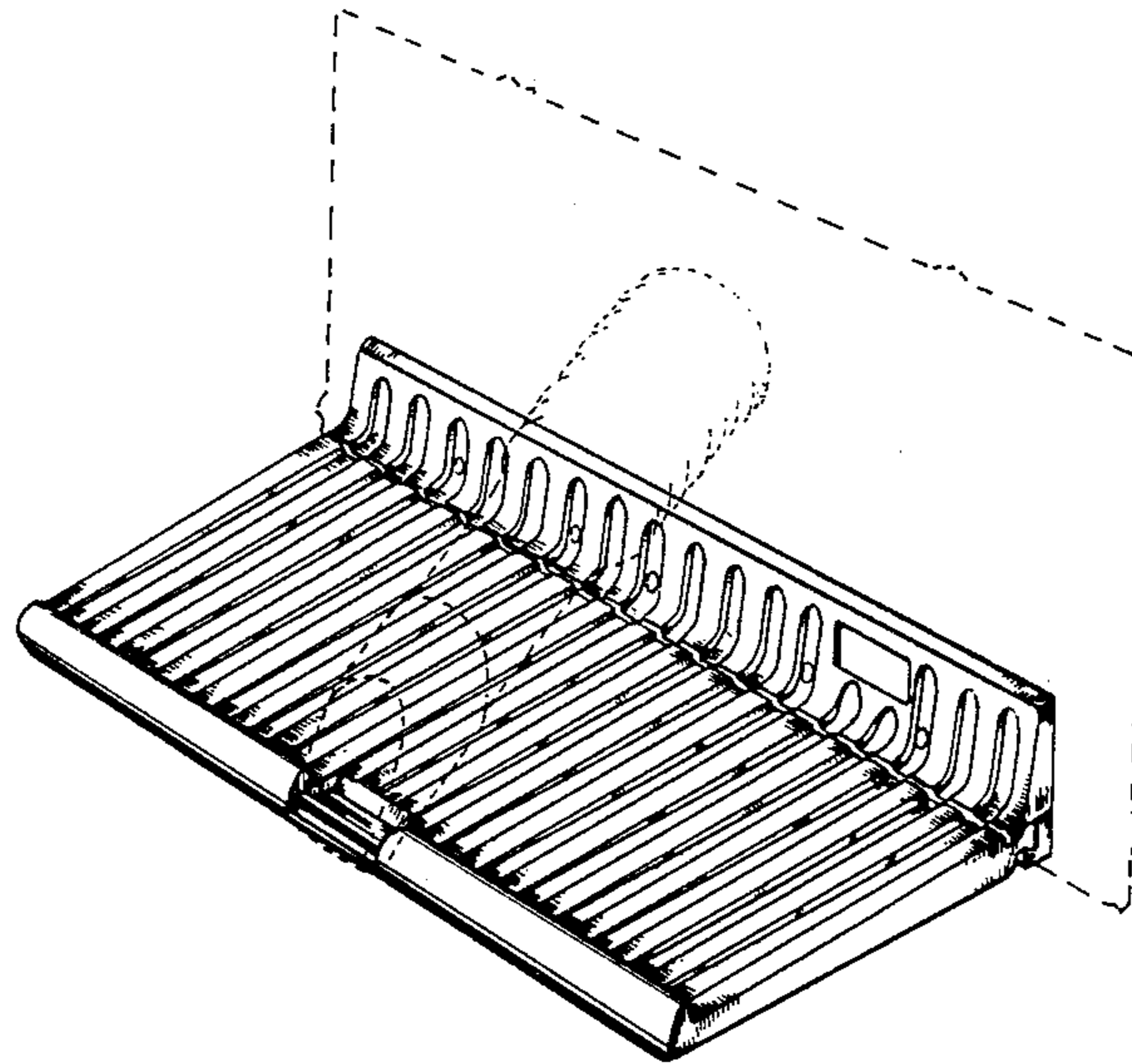

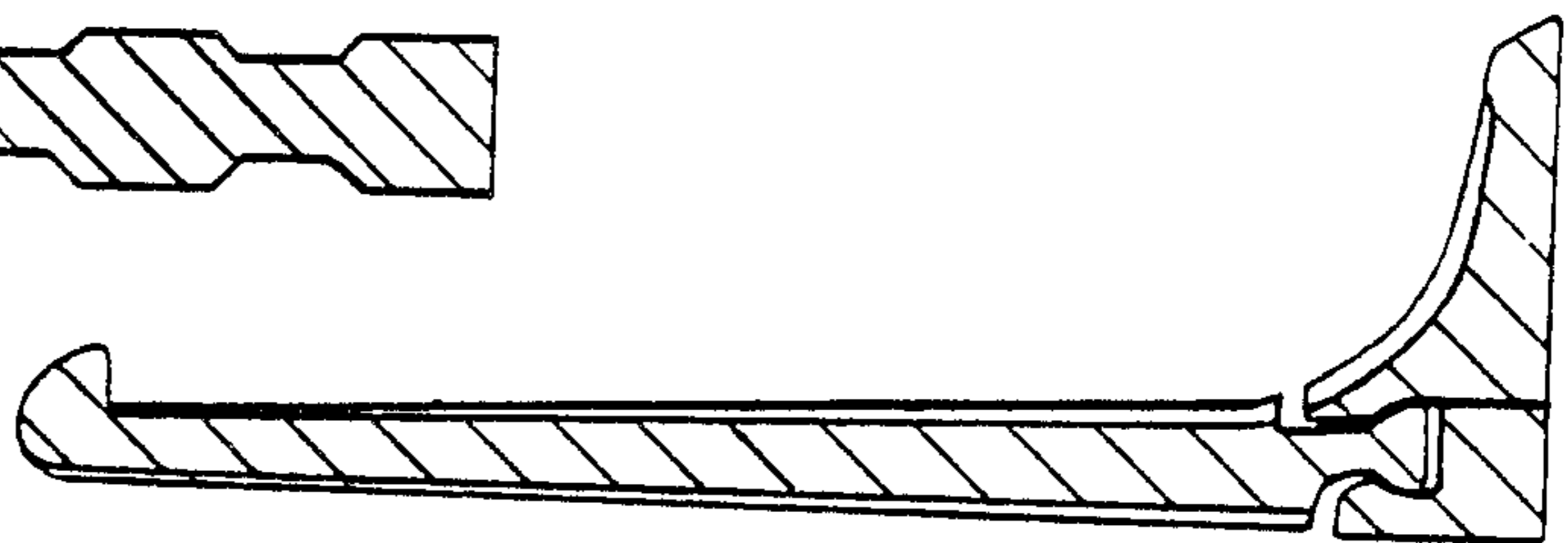
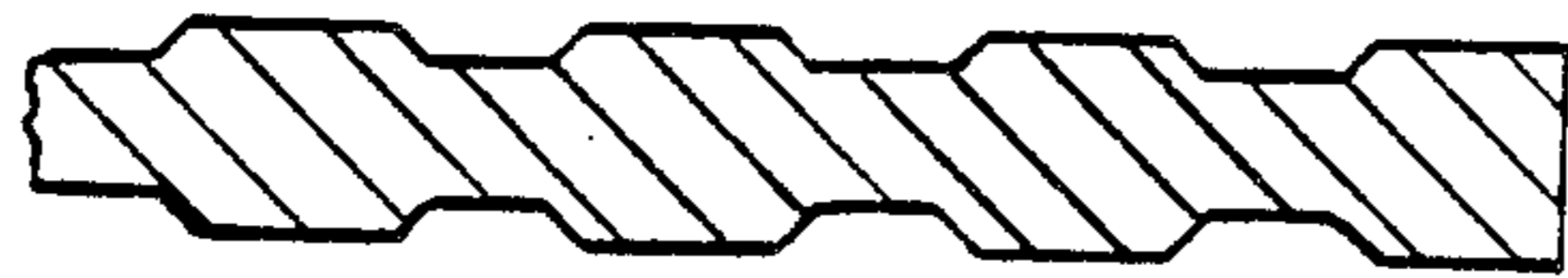
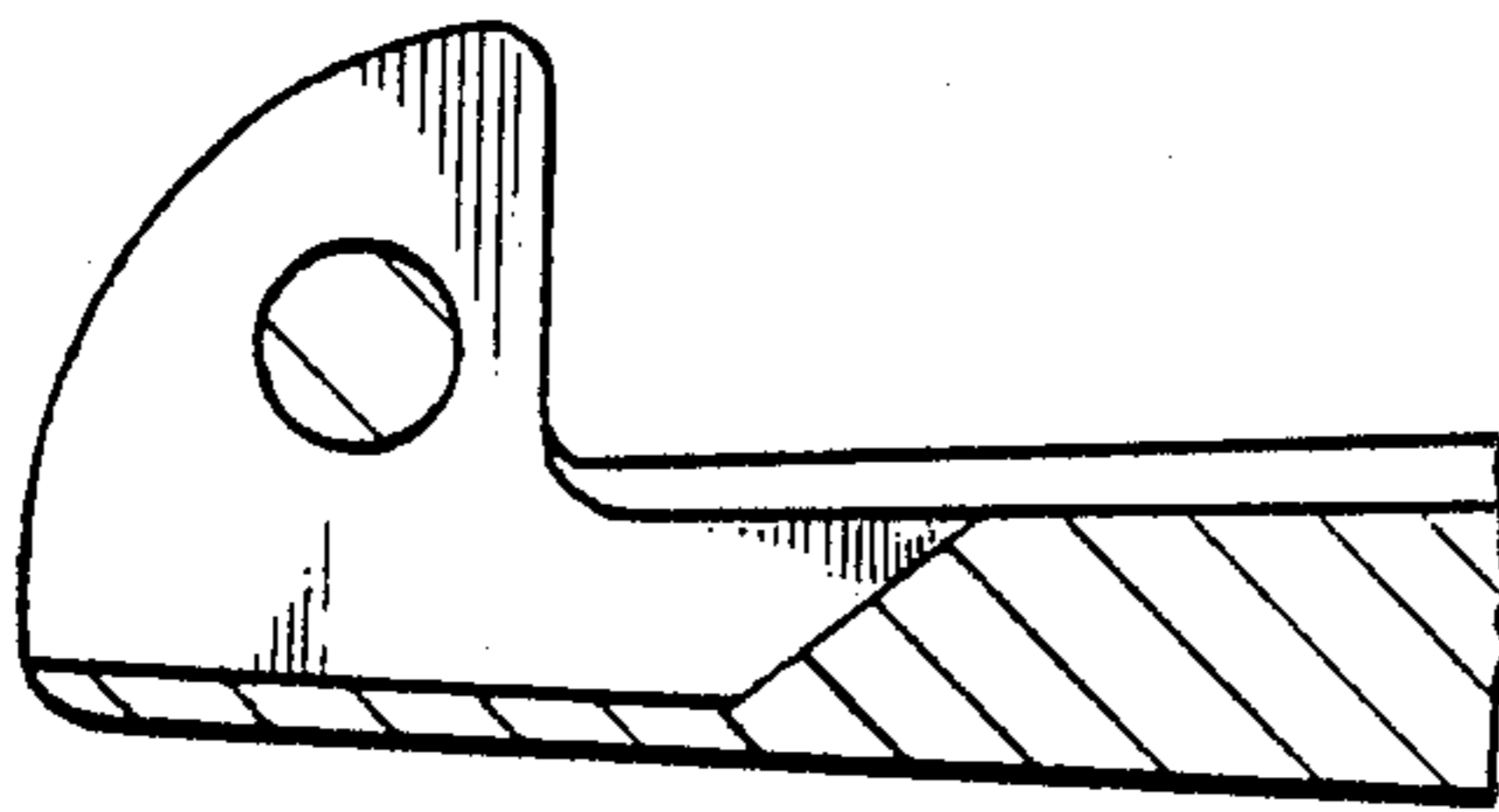
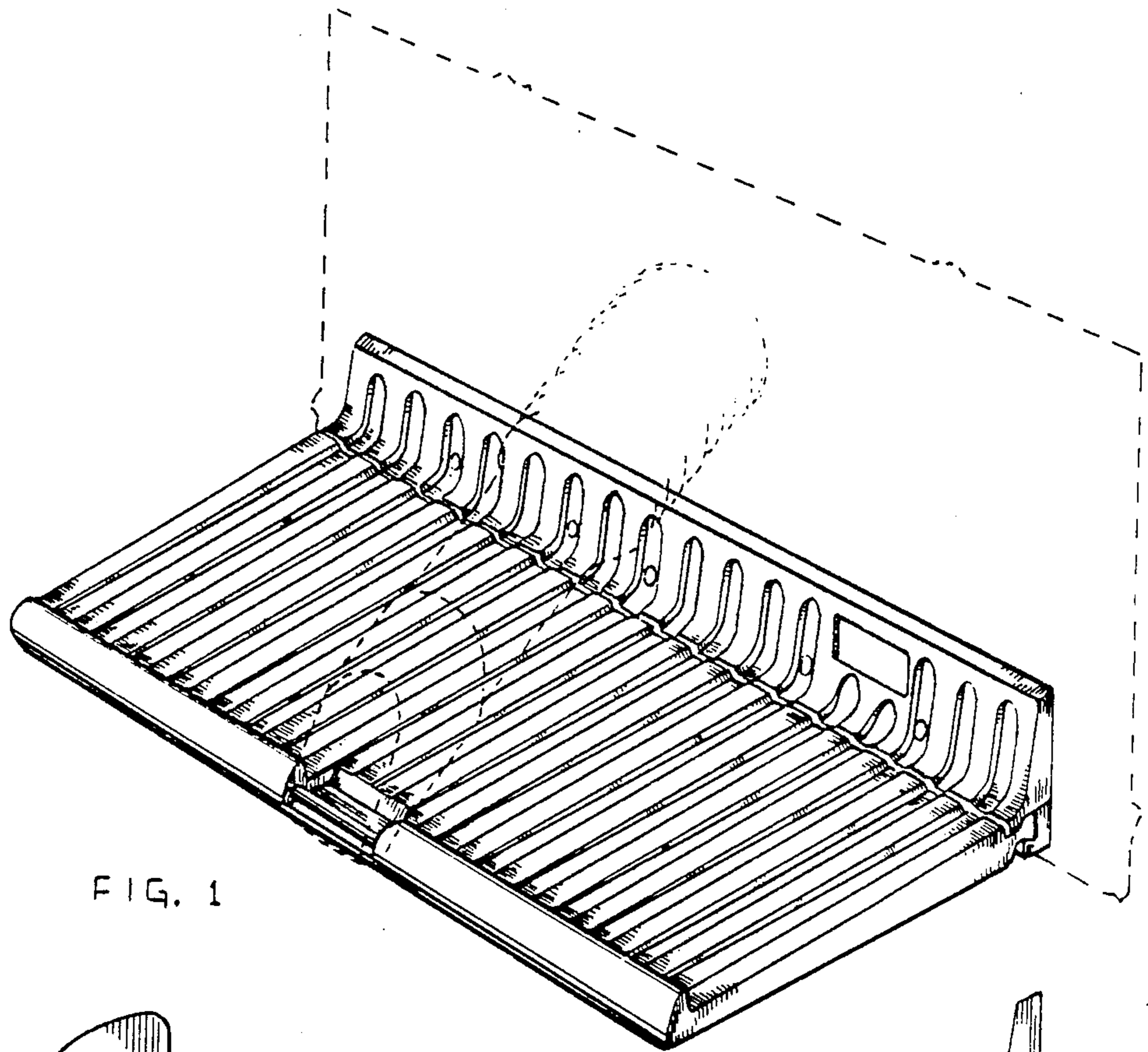

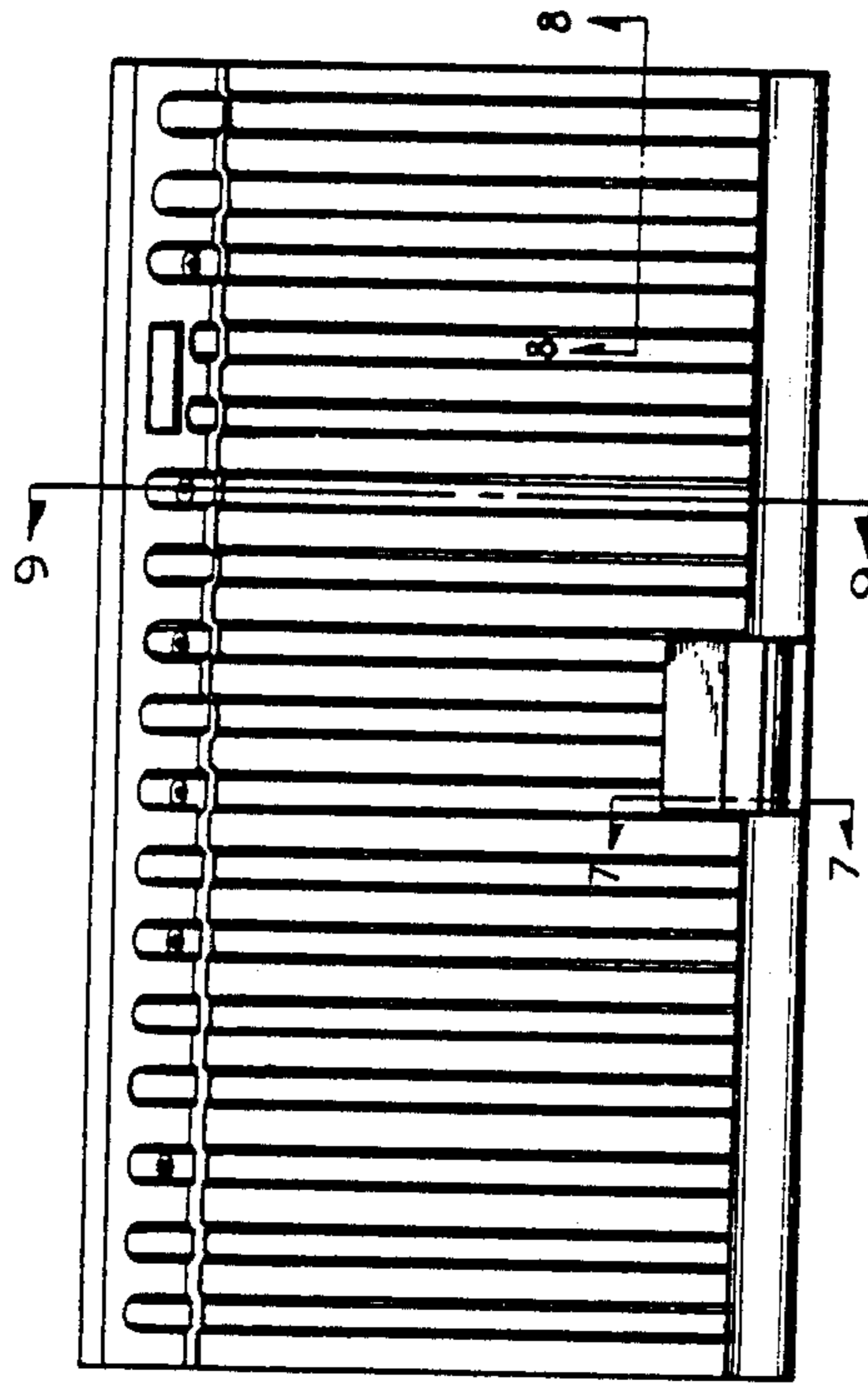

FIG. 2

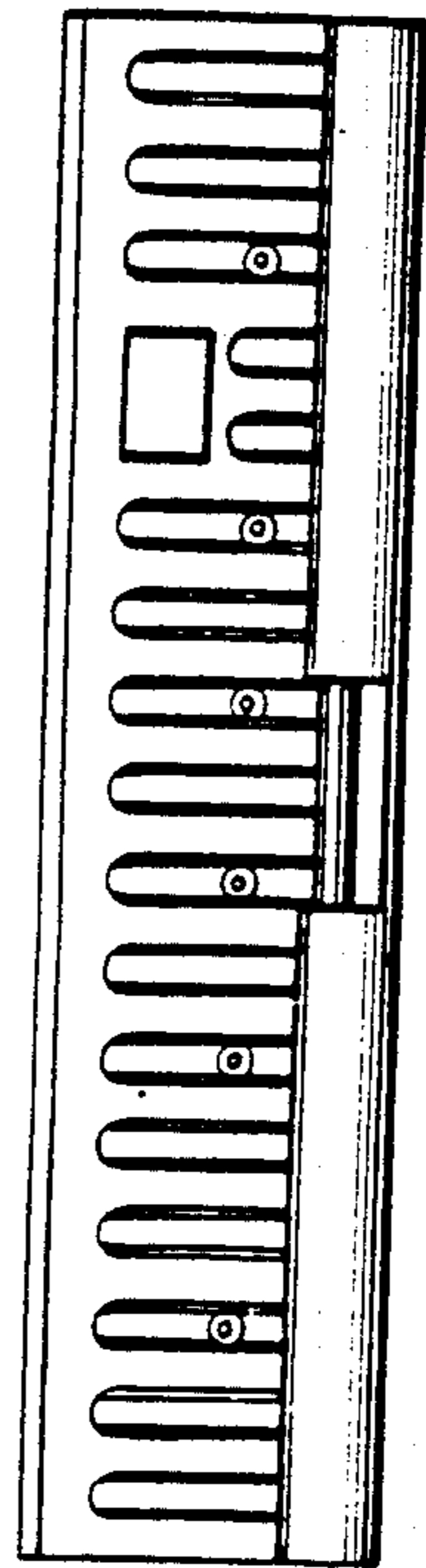

FIG. 3

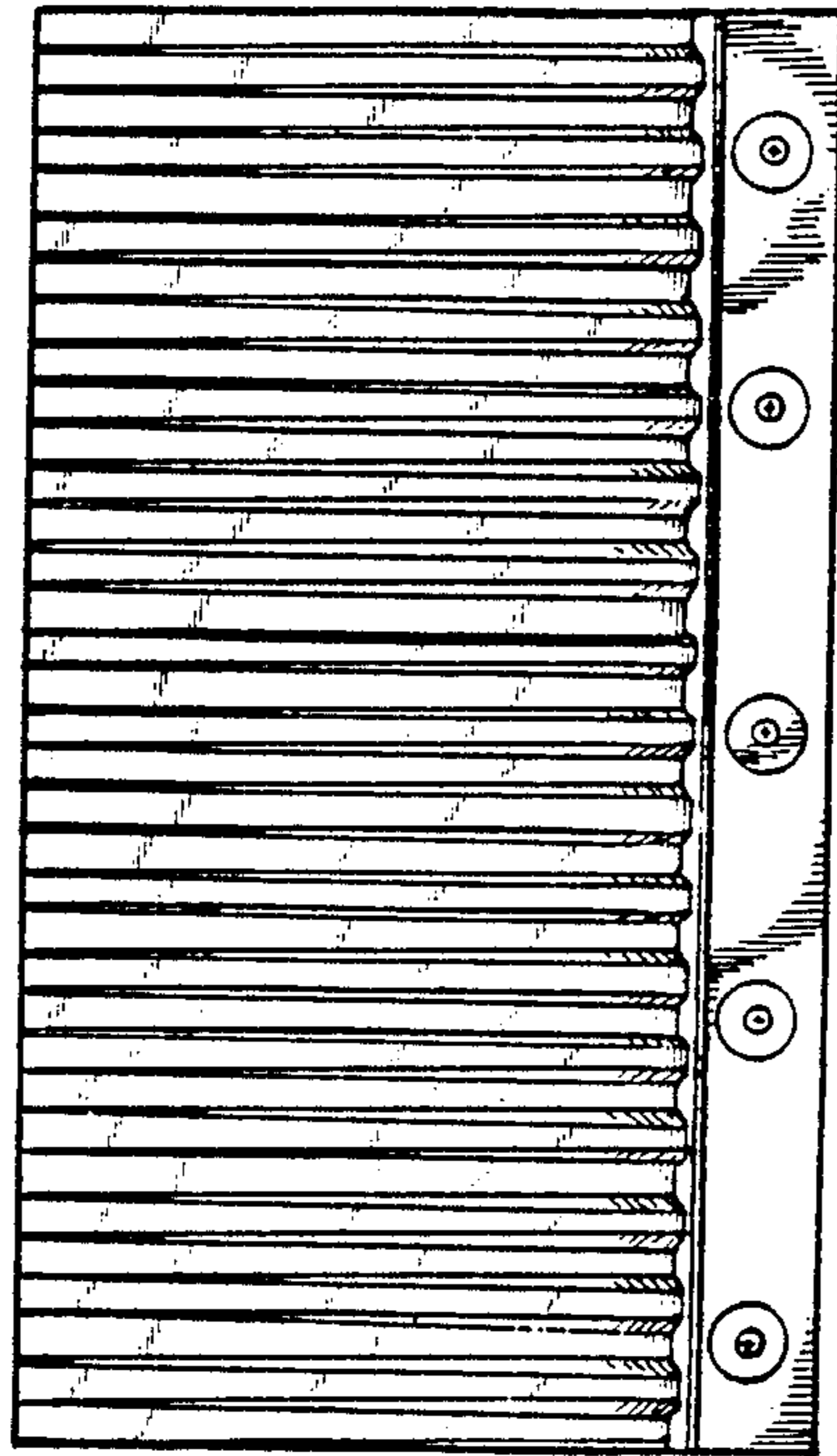

FIG. 4

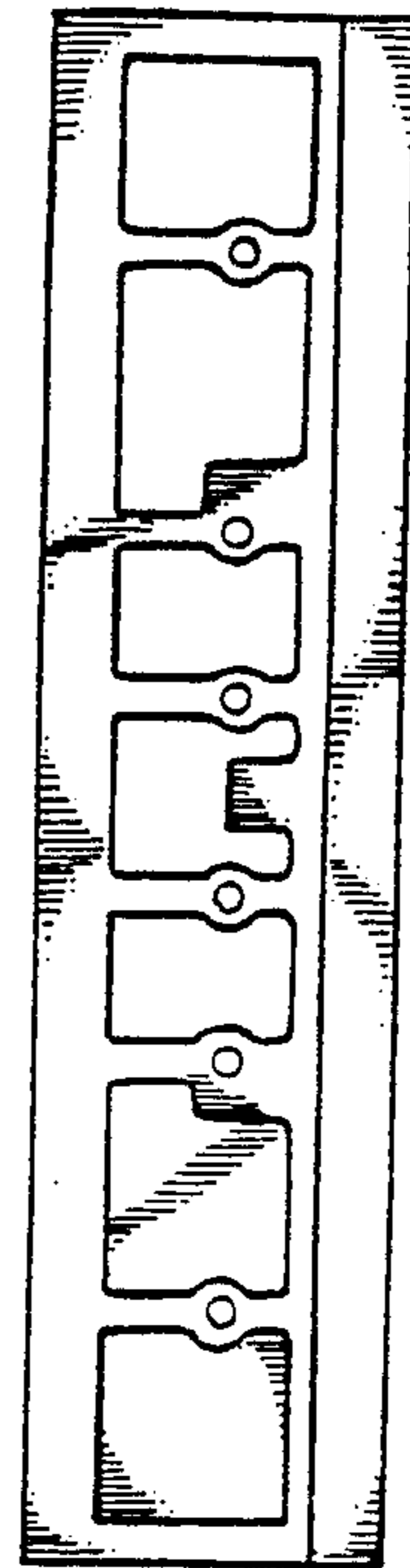

FIG. 5