

[54] BRACKET FOR MOUNTING OUTBOARD ENGINE BEHIND BOAT TRANSOM

[75] Inventor: Ronald D. Schlesch, Stuart, Fla.
 [73] Assignee: Armstrong International Inc., Three Rivers, Mich.
 [**] Term: 14 Years
 [21] Appl. No.: 690,030
 [22] Filed: Jan. 9, 1985
 [52] U.S. Cl. D12/317; D15/4; D8/373
 [58] Field of Search D8/373, 363, 380; 248/640, 641, 642, 643, 300; 440/49, 50, 900; D12/300, 317

[56] References Cited

U.S. PATENT DOCUMENTS

D. 278,622	4/1985	Hunnell	D12/317
D. 279,561	7/1985	Hathorne	D12/317
D. 288,205	2/1987	Bergeron	D12/317 X
1,704,303	3/1929	Savage	248/641
2,713,846	7/1955	Staley	248/641 X
2,822,142	2/1958	Collins	248/641
2,842,086	7/1958	Yost	248/641
2,886,462	5/1959	Jagiel	248/641 X
2,916,009	12/1959	Baird	248/586 X
2,928,630	3/1960	Wisman	248/641
2,928,631	3/1960	Hartman	248/641
2,954,192	9/1960	Baird	248/641
3,032,304	5/1962	Machlan	440/900 X
3,245,641	4/1966	Hart	248/641
3,578,277	5/1971	Osborn	248/642
3,750,988	8/1973	Lyon	440/900 X
3,877,667	4/1975	Monckton	248/641
3,918,666	11/1975	Florian	248/641
4,077,353	3/1978	Webb, Jr.	440/55
4,239,172	12/1980	Spitzmesser	248/641
4,448,387	5/1984	Gilbreath	248/642
4,482,330	11/1984	Cook	248/640 X
4,501,562	2/1985	Blanchard	248/642 X
4,545,559	10/1985	Gilbreath	248/642

FOREIGN PATENT DOCUMENTS

2032372 5/1980 United Kingdom 248/643

Primary Examiner—Wallace R. Burke

Assistant Examiner—Horace B. Fay

Attorney, Agent, or Firm—Flynn, Thiel, Boutell & Tanis

[57] CLAIM

The ornamental design for a bracket for mounting outboard engine behind boat transom, as shown and described.

DESCRIPTION

FIG. 1 is a front, top and right side perspective view of a bracket for mounting outboard engine behind boat transom showing my new design;
 FIG. 2 is an enlarged top plan view thereof;
 FIG. 3 is a left side elevational view thereof, the right side being a mirror image;
 FIG. 4 is a bottom plan view thereof;
 FIGS. 5 and 6 are respectively front and rear elevational views thereof;
 FIG. 7 is a sectional view taken substantially on line VII—VII of FIG. 2;
 FIG. 8 is a front, top and right side perspective view of a second embodiment thereof, the sole exception being the addition of a top wing unit incorporated at the front end;
 FIG. 9 is an enlarged top plan view thereof;
 FIG. 10 is a left side elevational view thereof, the right side view being a mirror image;
 FIG. 11 is a bottom plan view thereof;
 FIG. 12 is a front elevational view thereof;
 FIG. 13 is a rear elevational view thereof;
 FIG. 14 is a front, top and right side perspective view of a third embodiment thereof, the exception being the addition of lower, outwardly extending tapered wings incorporated at the front end;
 FIG. 15 is an enlarged top plan view thereof;
 FIG. 16 is a left side elevational view thereof, the right side being substantially a mirror image;
 FIG. 17 is a bottom plan view thereof;
 FIGS. 18 and 19 are respectively front and rear elevational views thereof; and
 FIG. 20 is a perspective view thereof similar to FIG. 1, the sole differences being (1) the addition of a top wing unit at the front, and (2) the addition of lower outwardly extending tapered wings also at the front.
 The broken line showing of a power boat and a outboard engine is for illustrative, environmental associa-

(List continued on next page.)

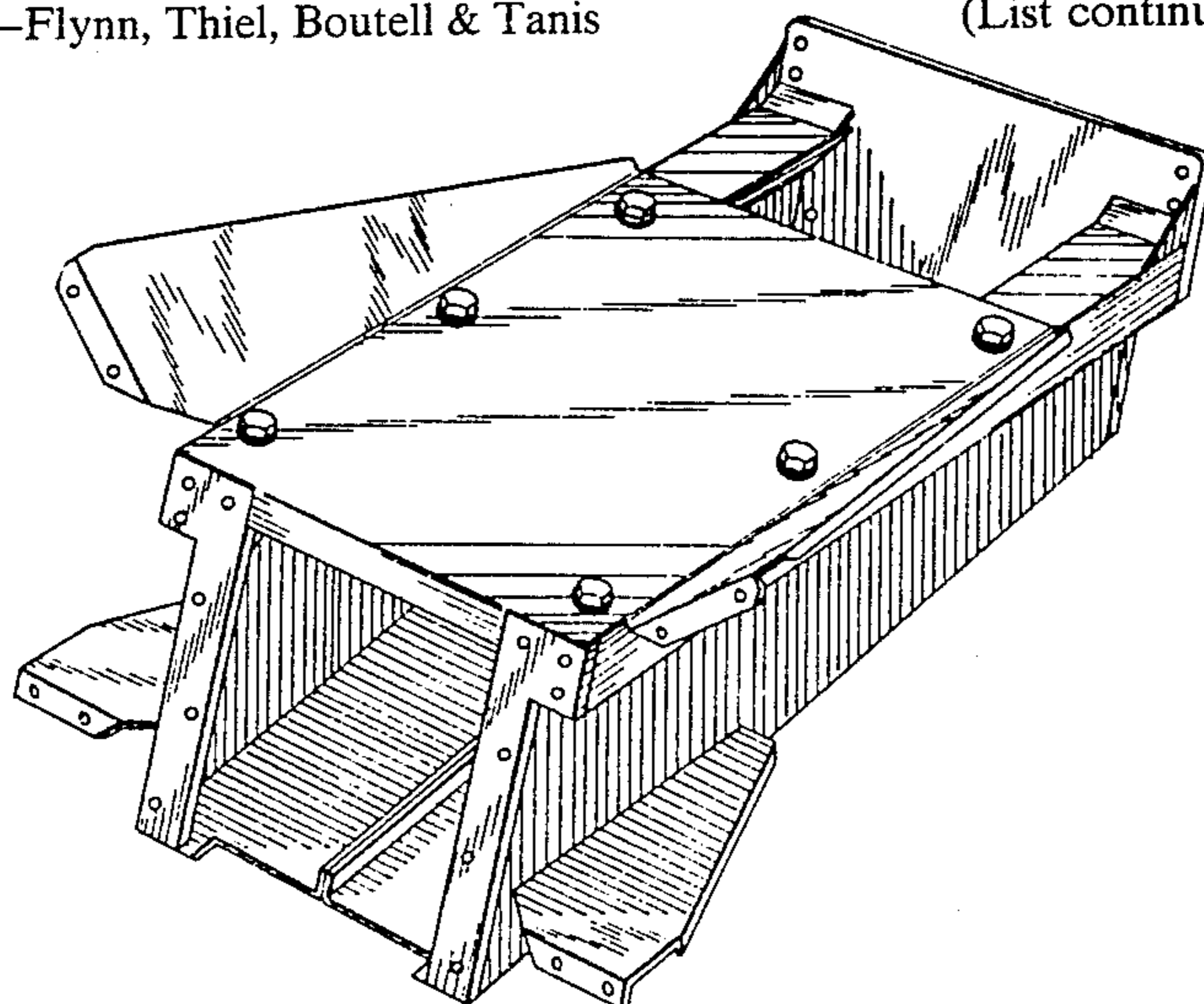

tional purposes only and forms no part of the claimed design.

The transom area of a conventional power boat and a conventional large outboard engine are shown in dotted lines in FIG. 3 with my new engine bracket design

typically installed to mount the outboard engine in spaced cantilevered relation from the rear face of the power boat transom, the structure shown in broken lines being provided as typical environmental structure and not being part of the design sought to be patented.

FIG. 1

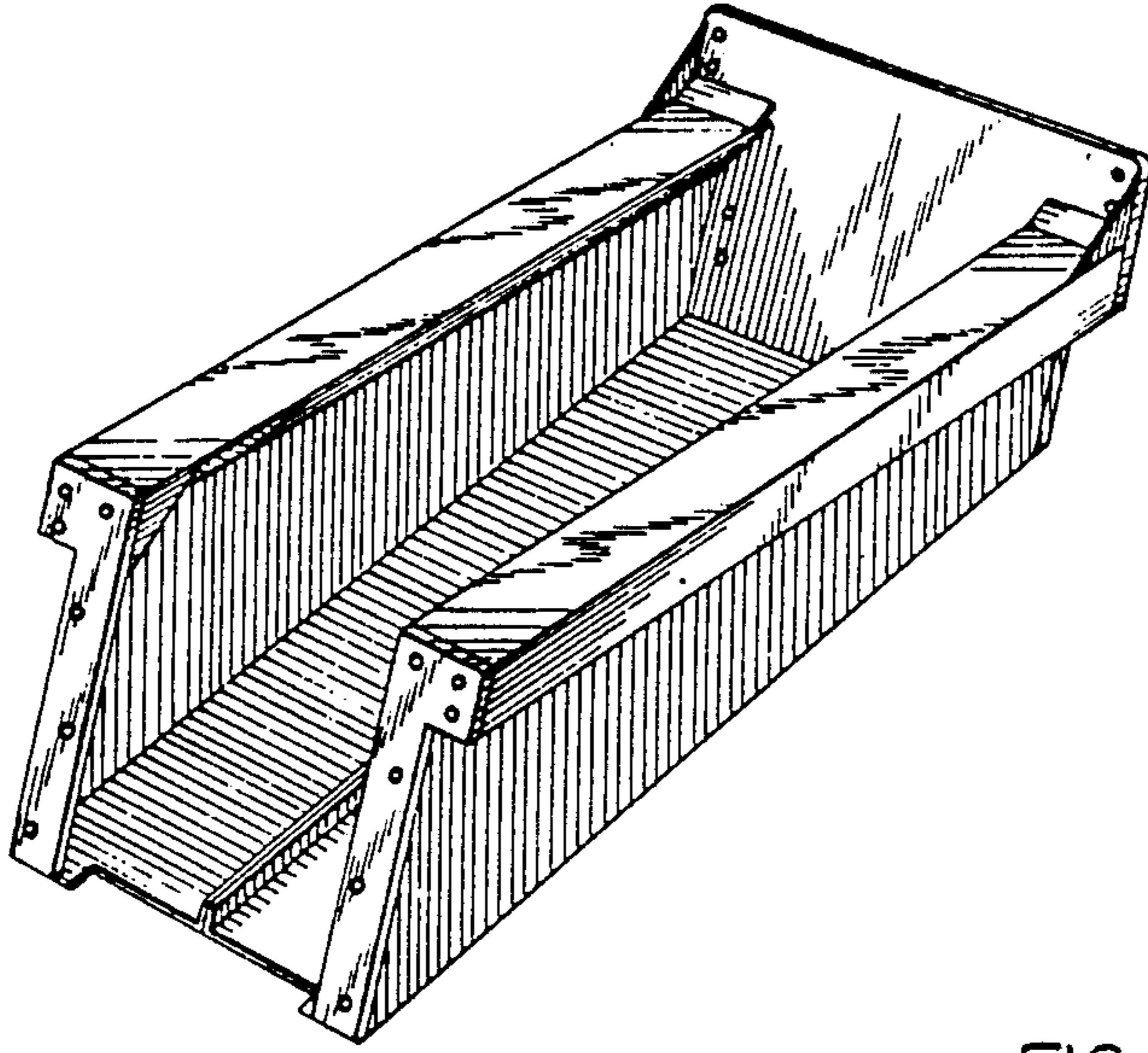

FIG. 2

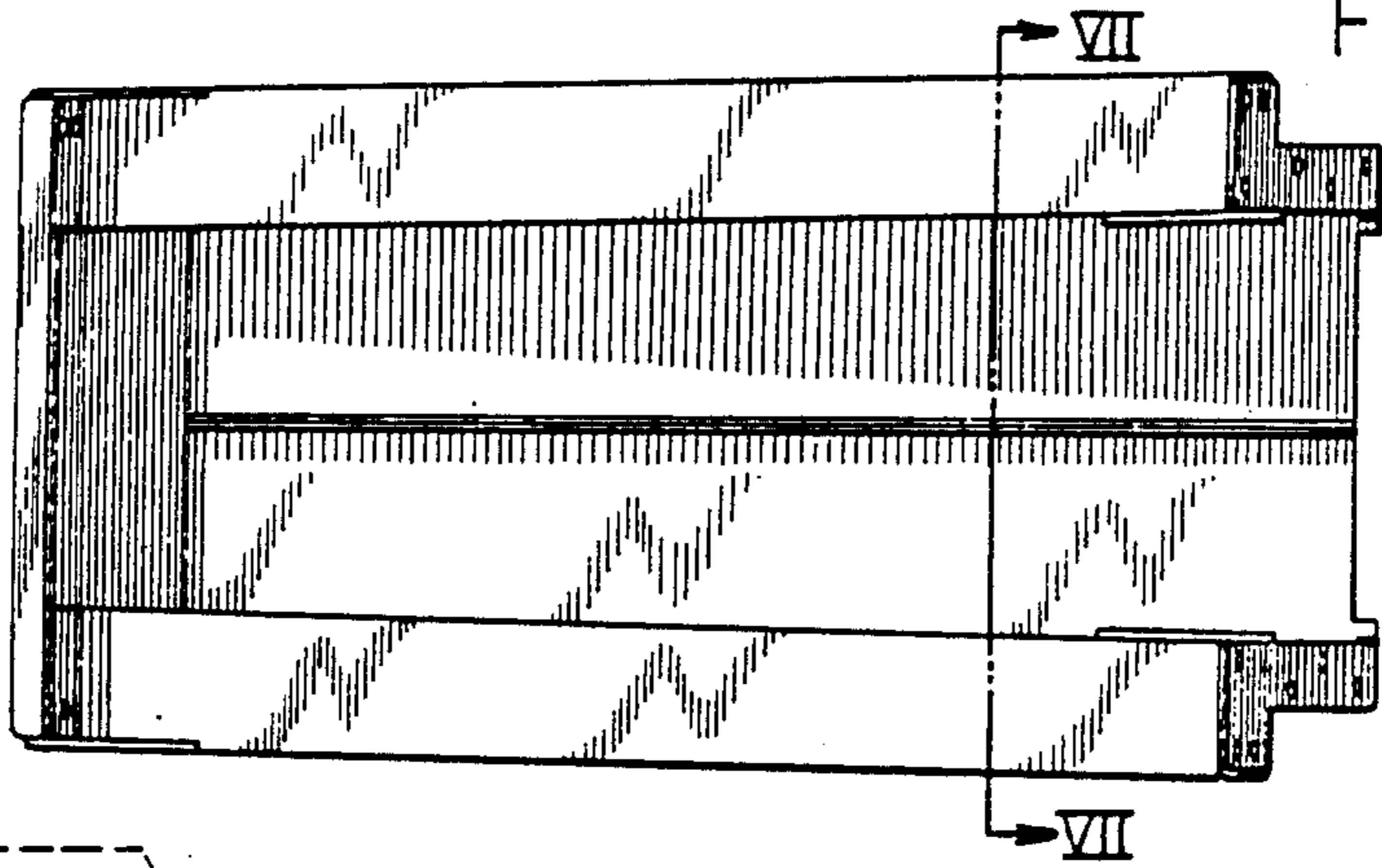
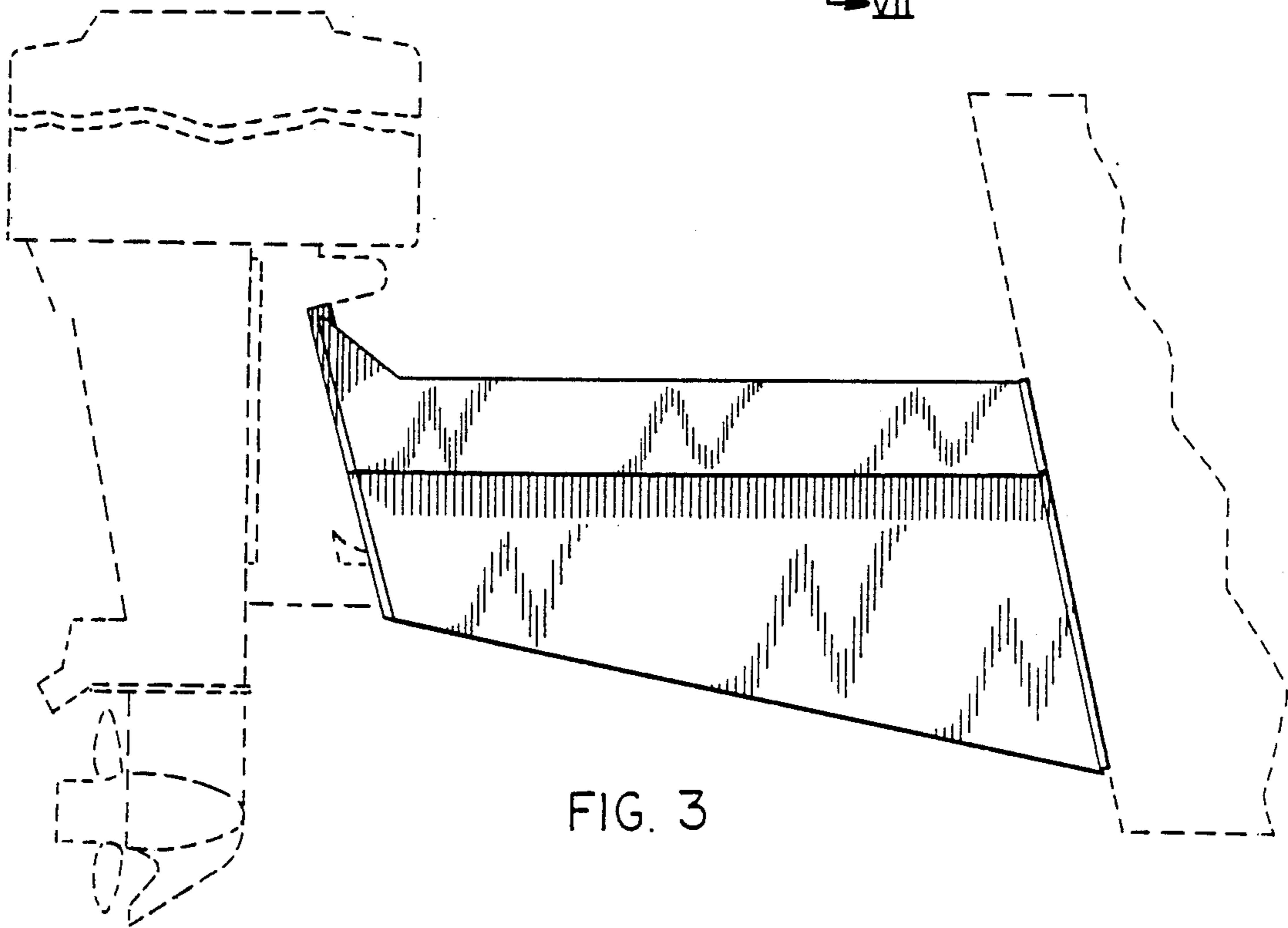

FIG. 3



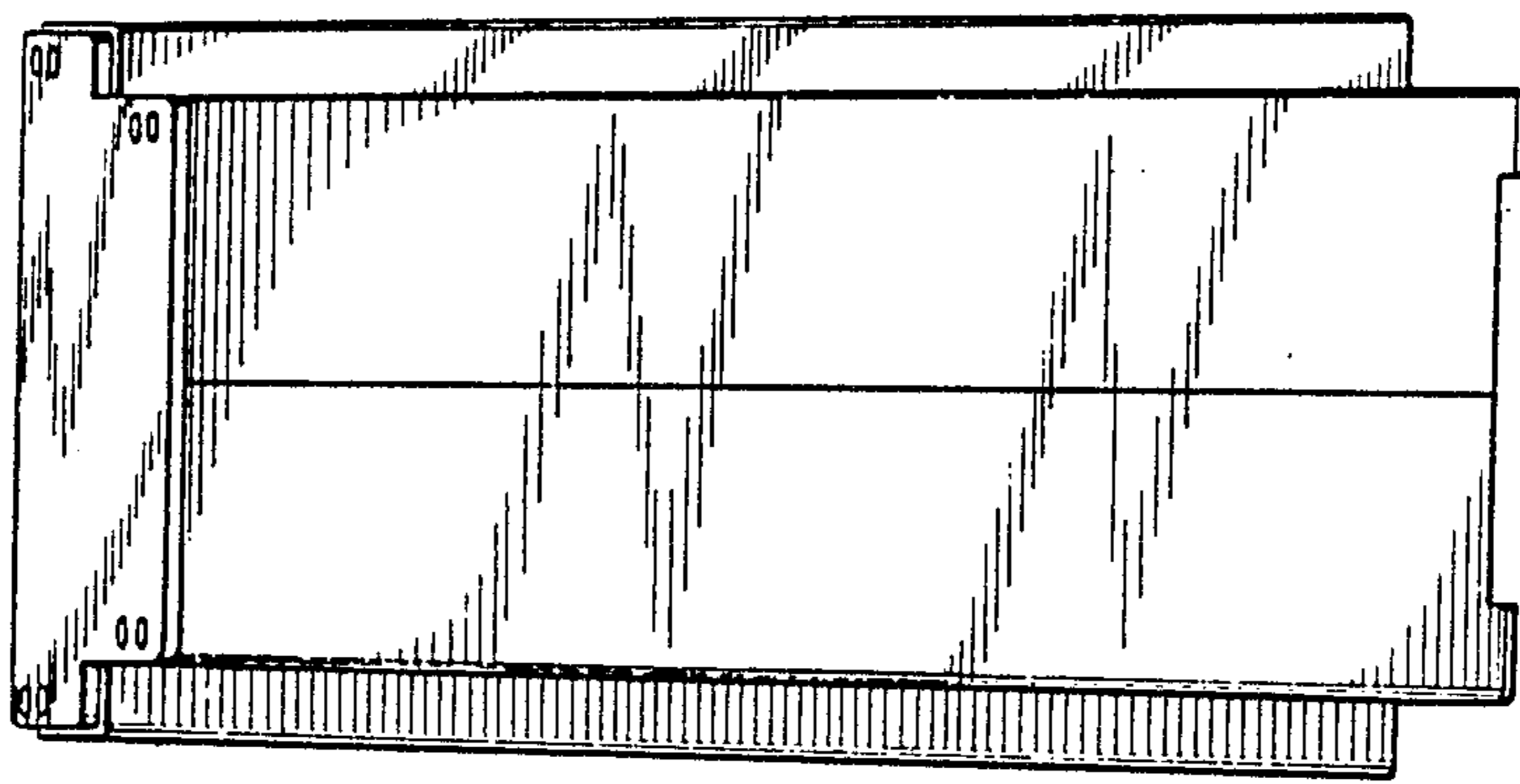

FIG. 4

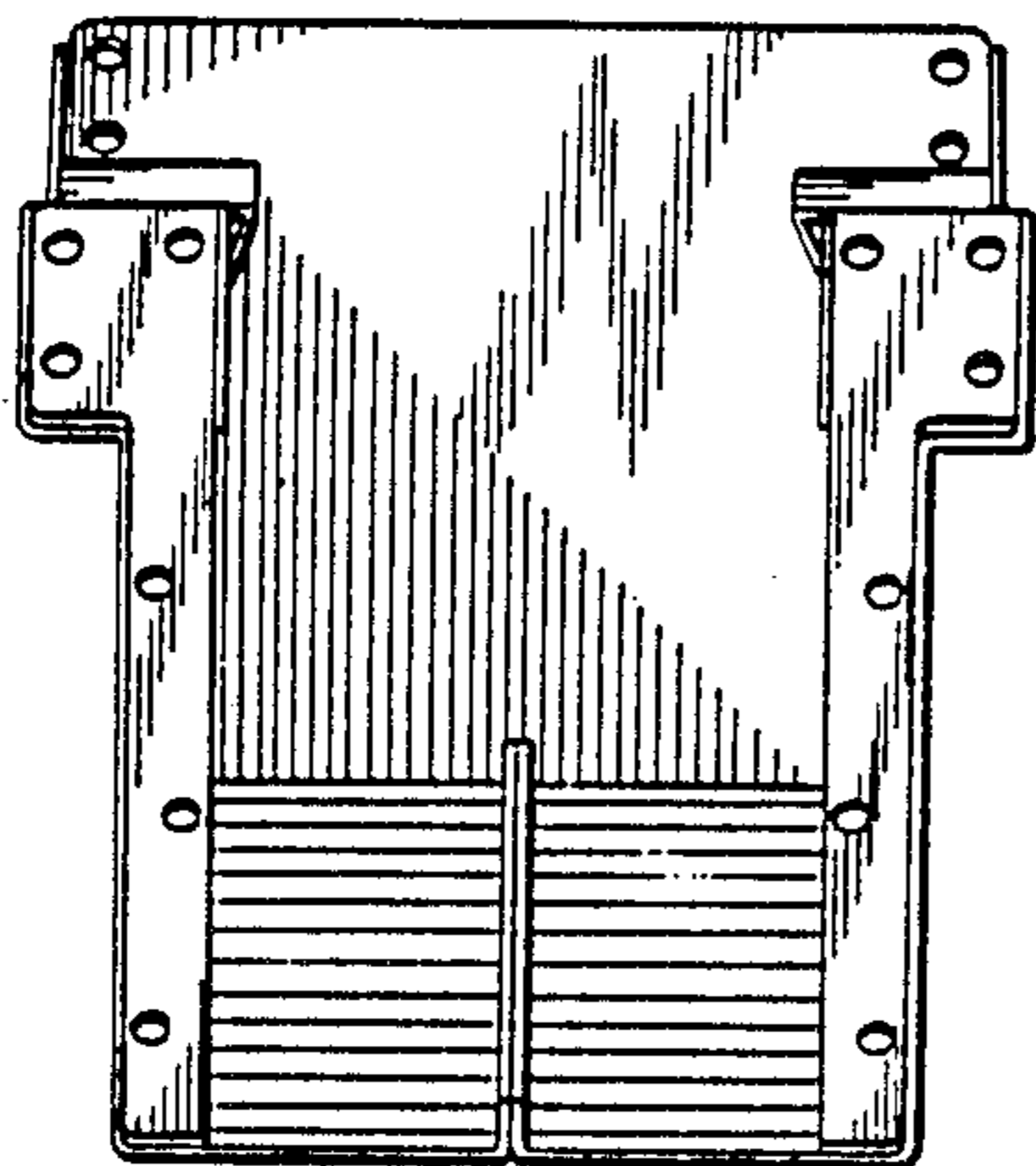

FIG. 5

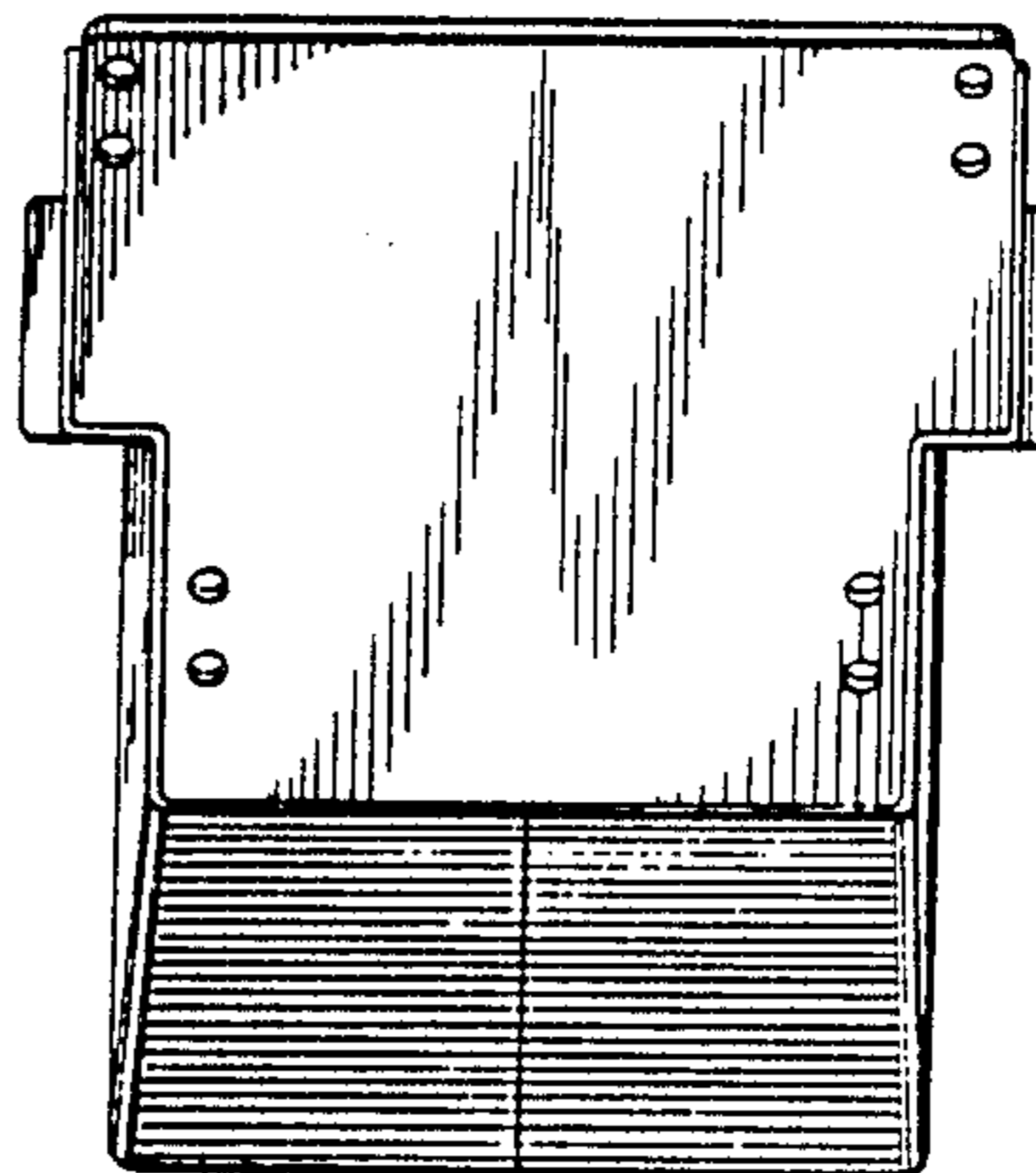

FIG. 6

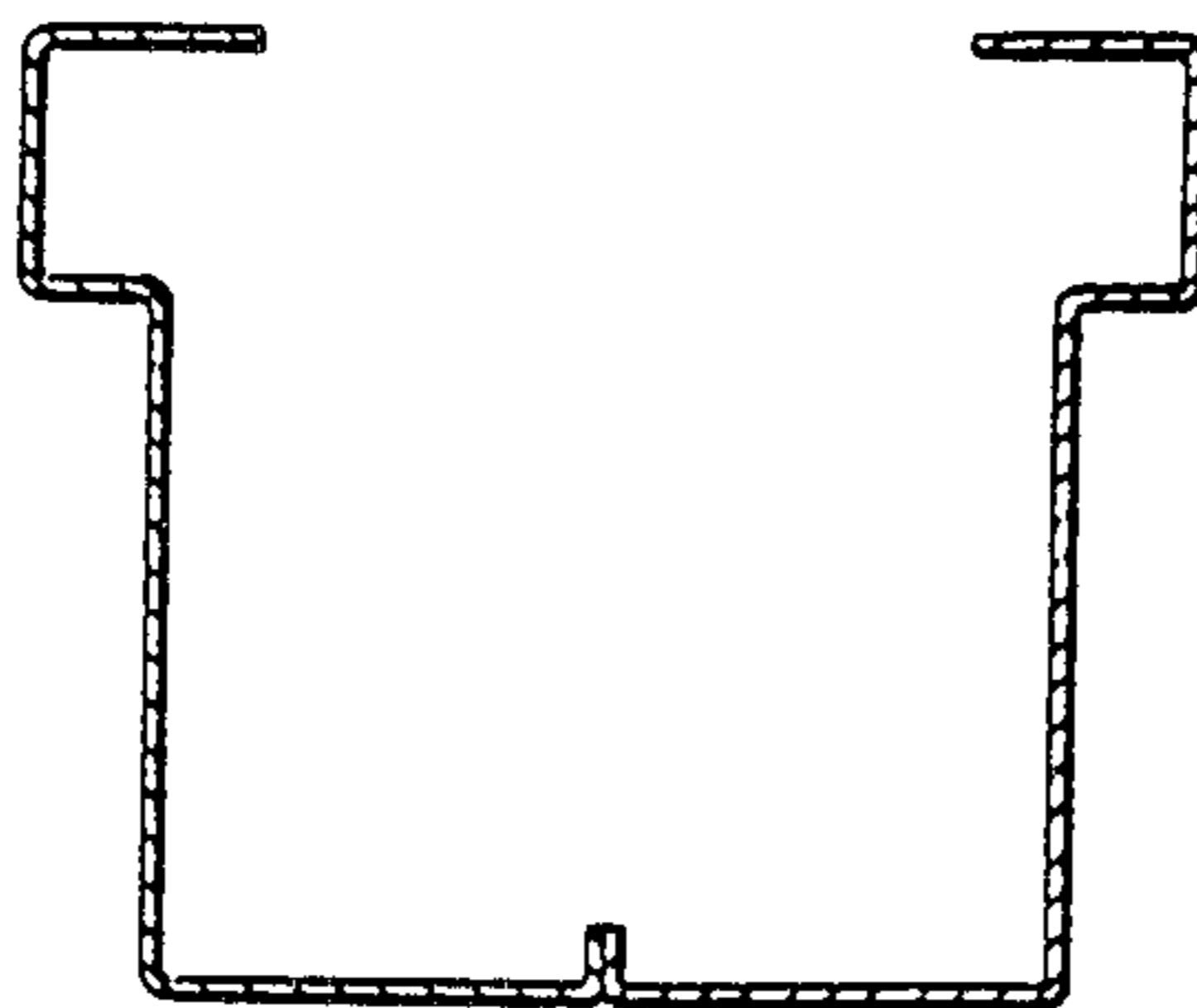

FIG. 7

FIG. 8

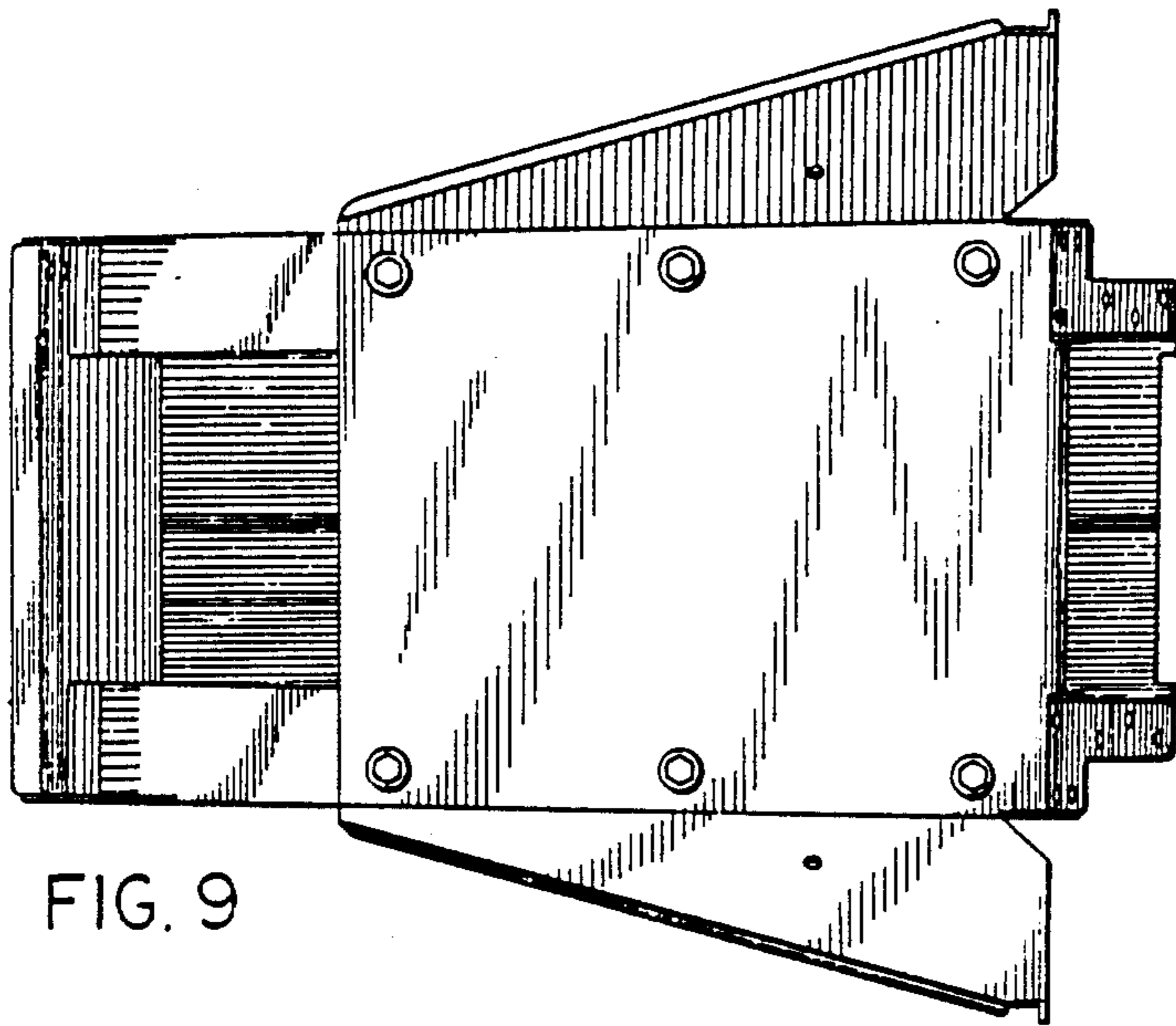
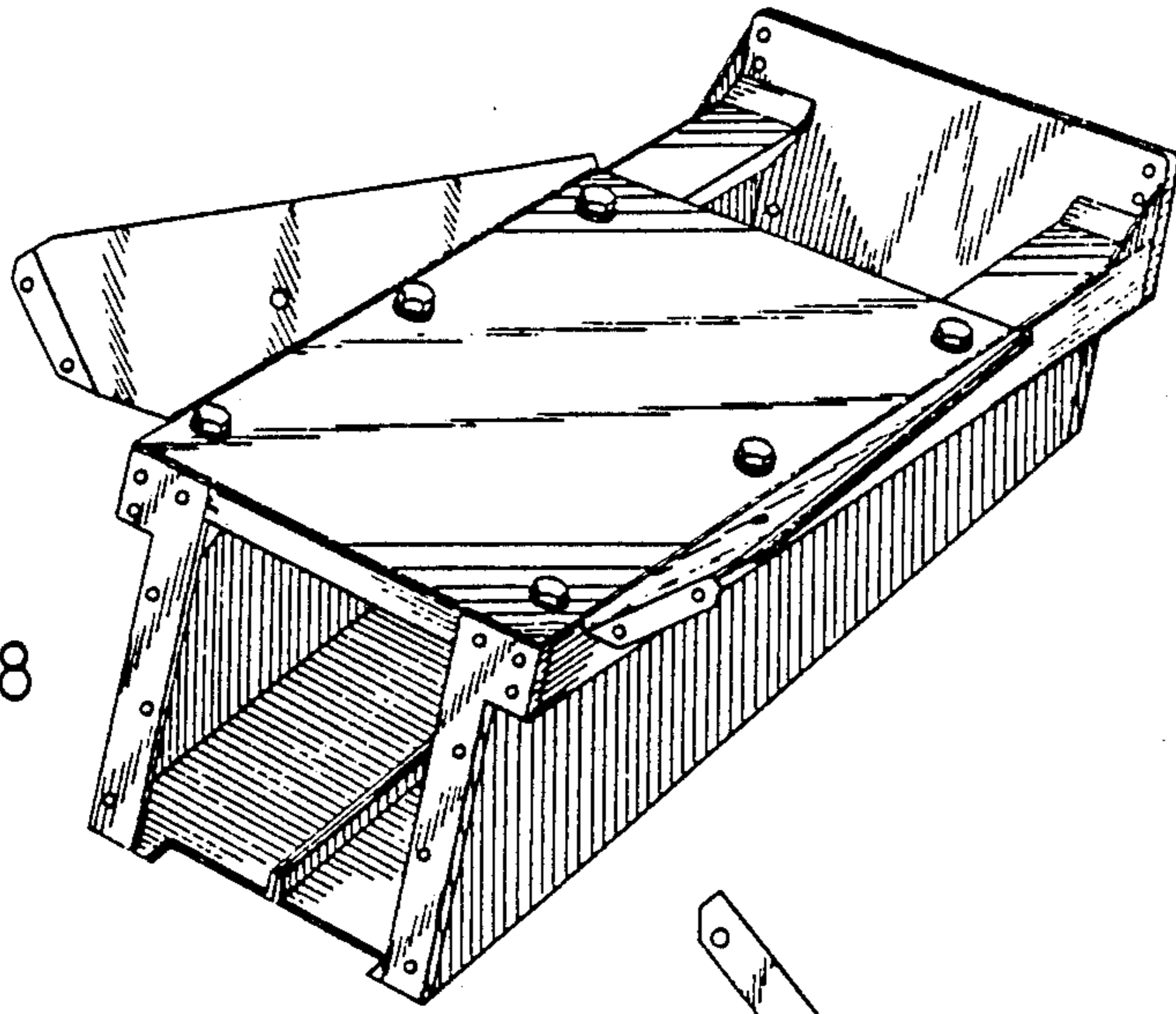

FIG. 9

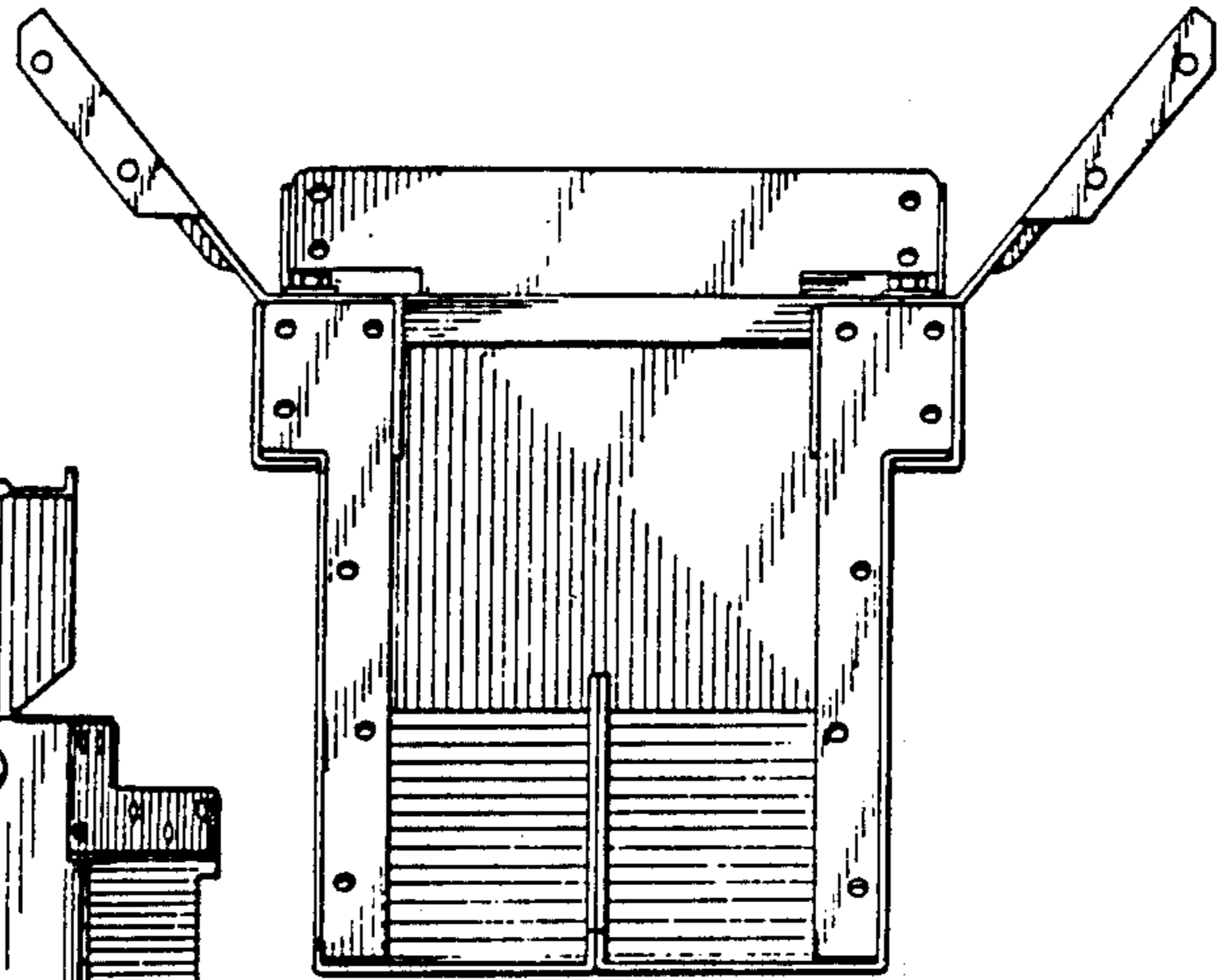

FIG. 12

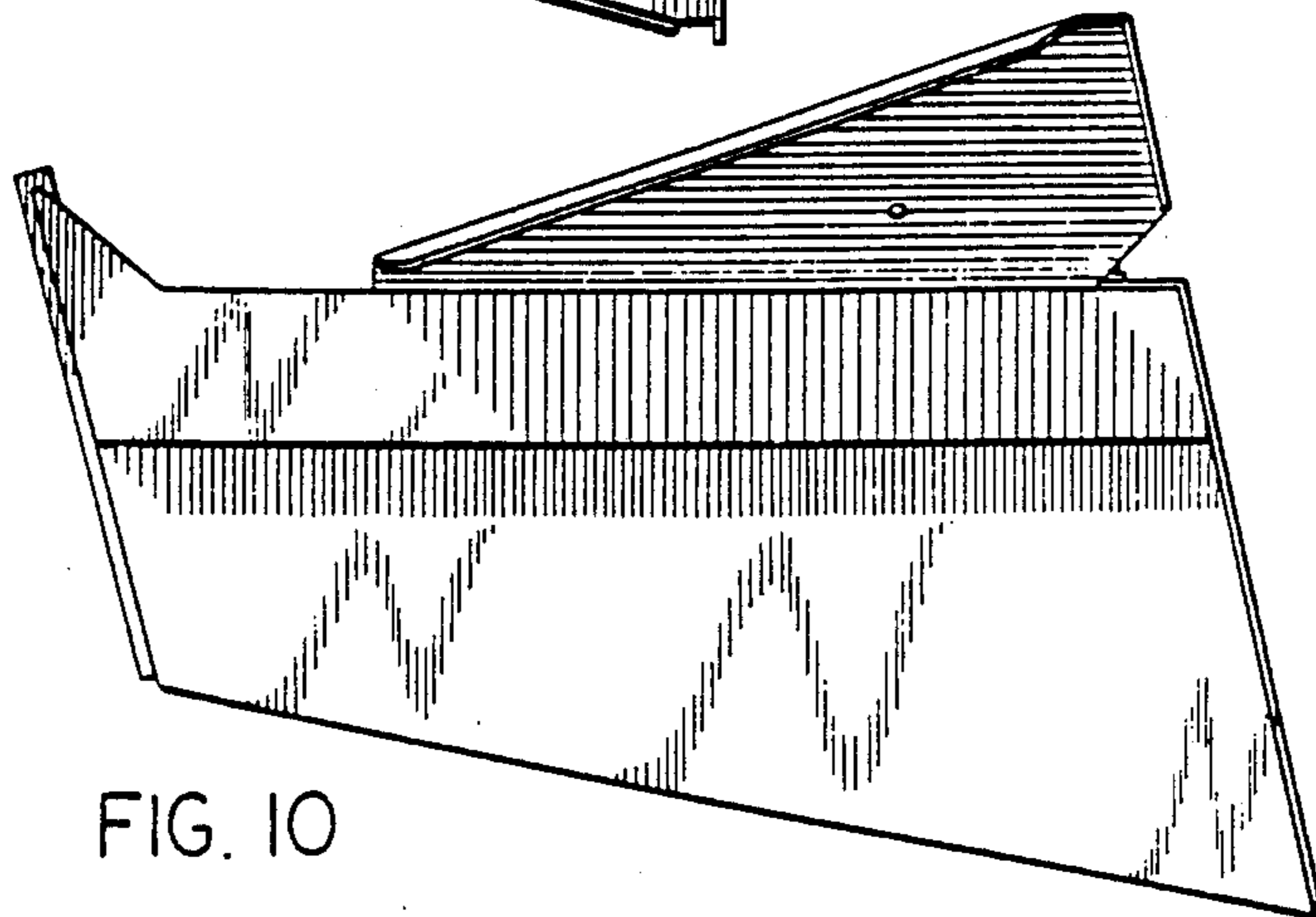

FIG. 10

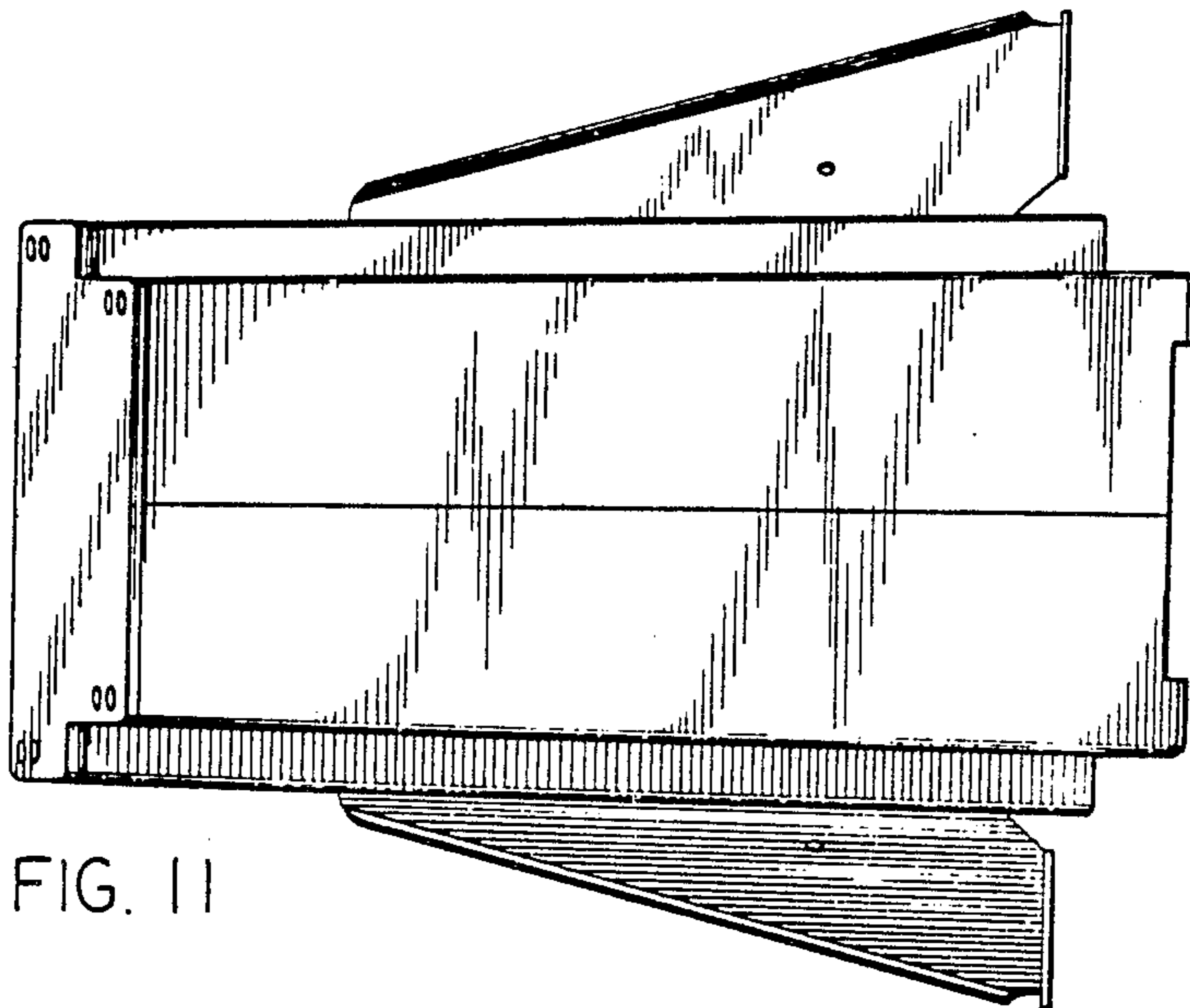

FIG. 11

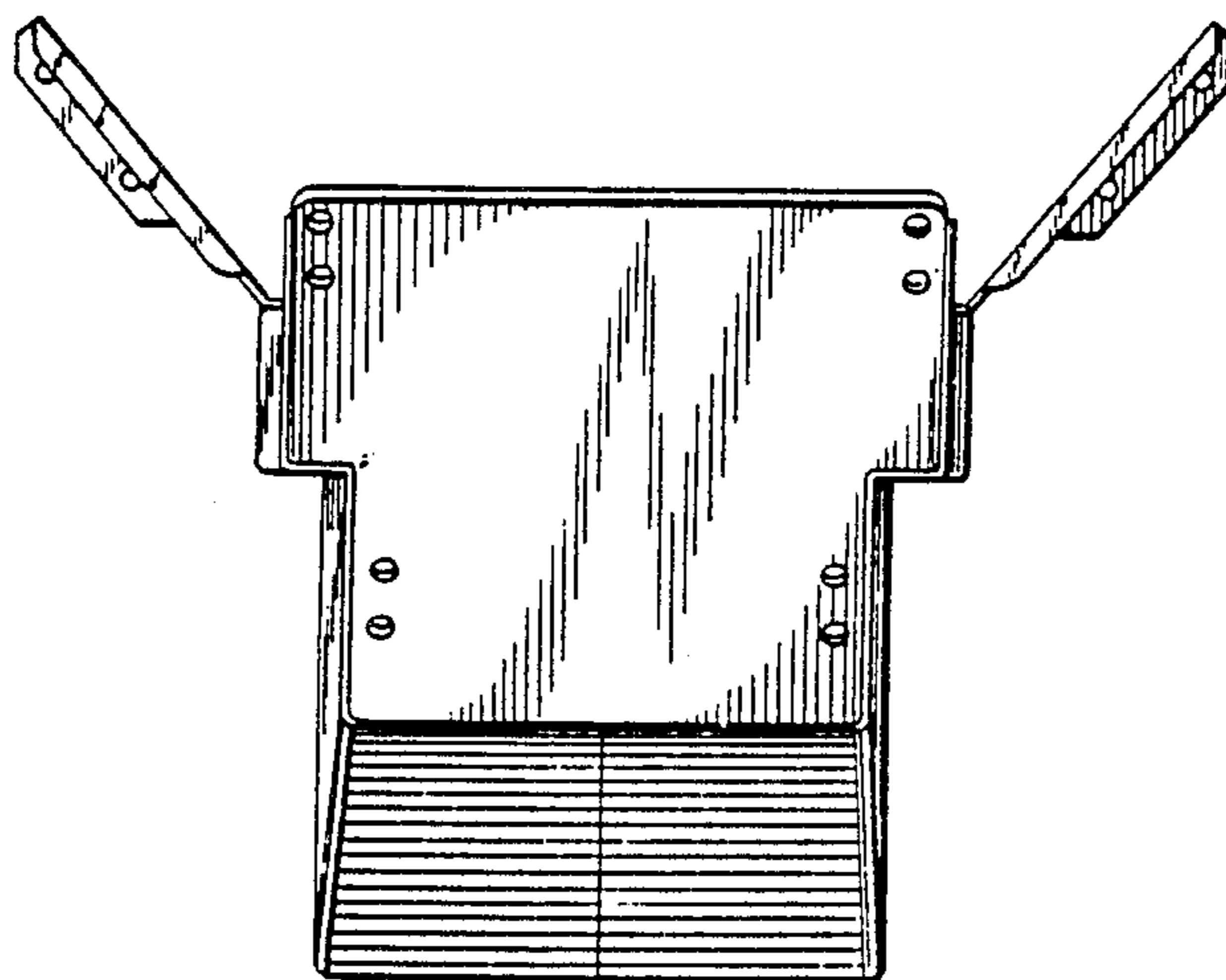

FIG. 13

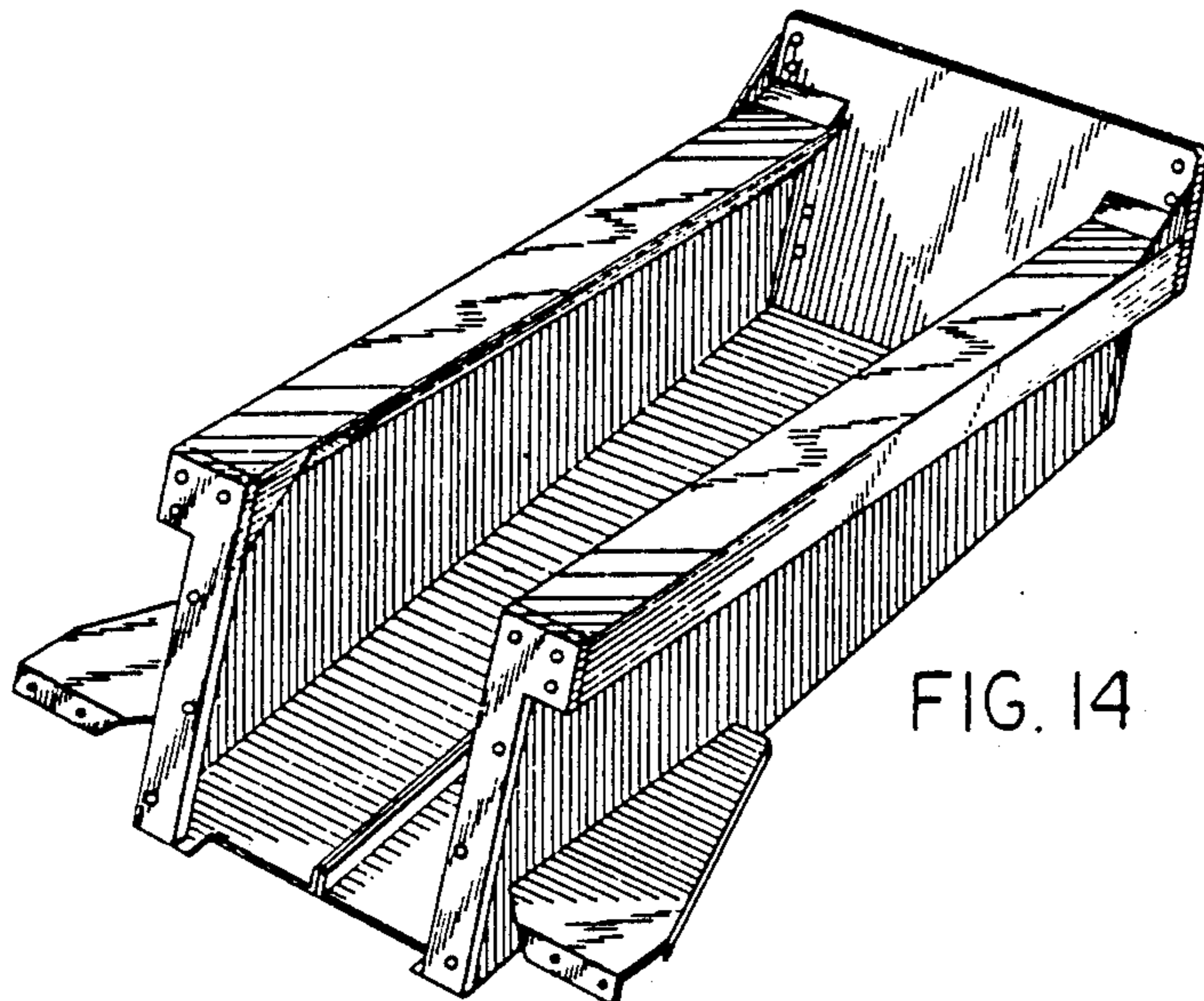

FIG. 14

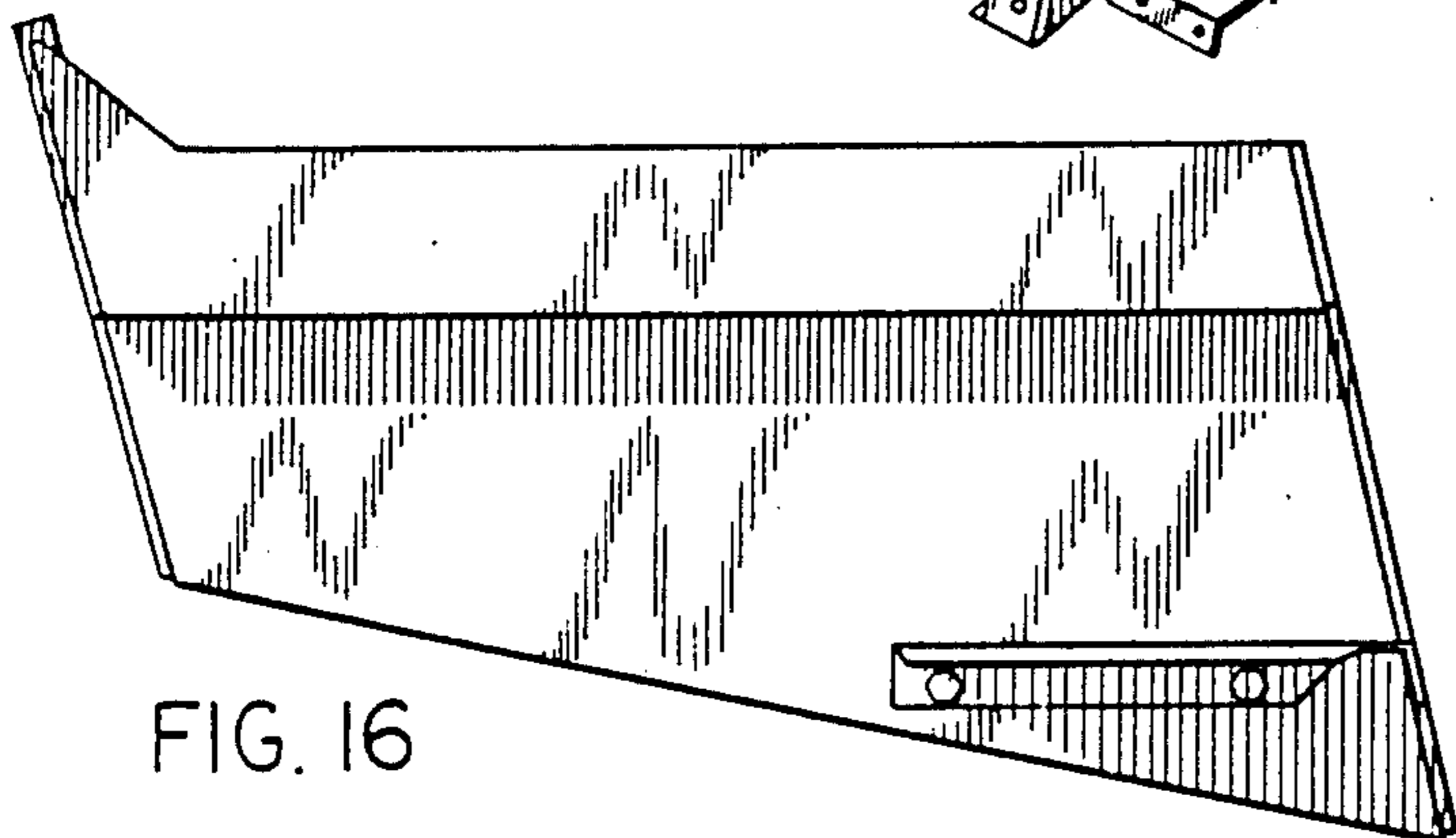

FIG. 16

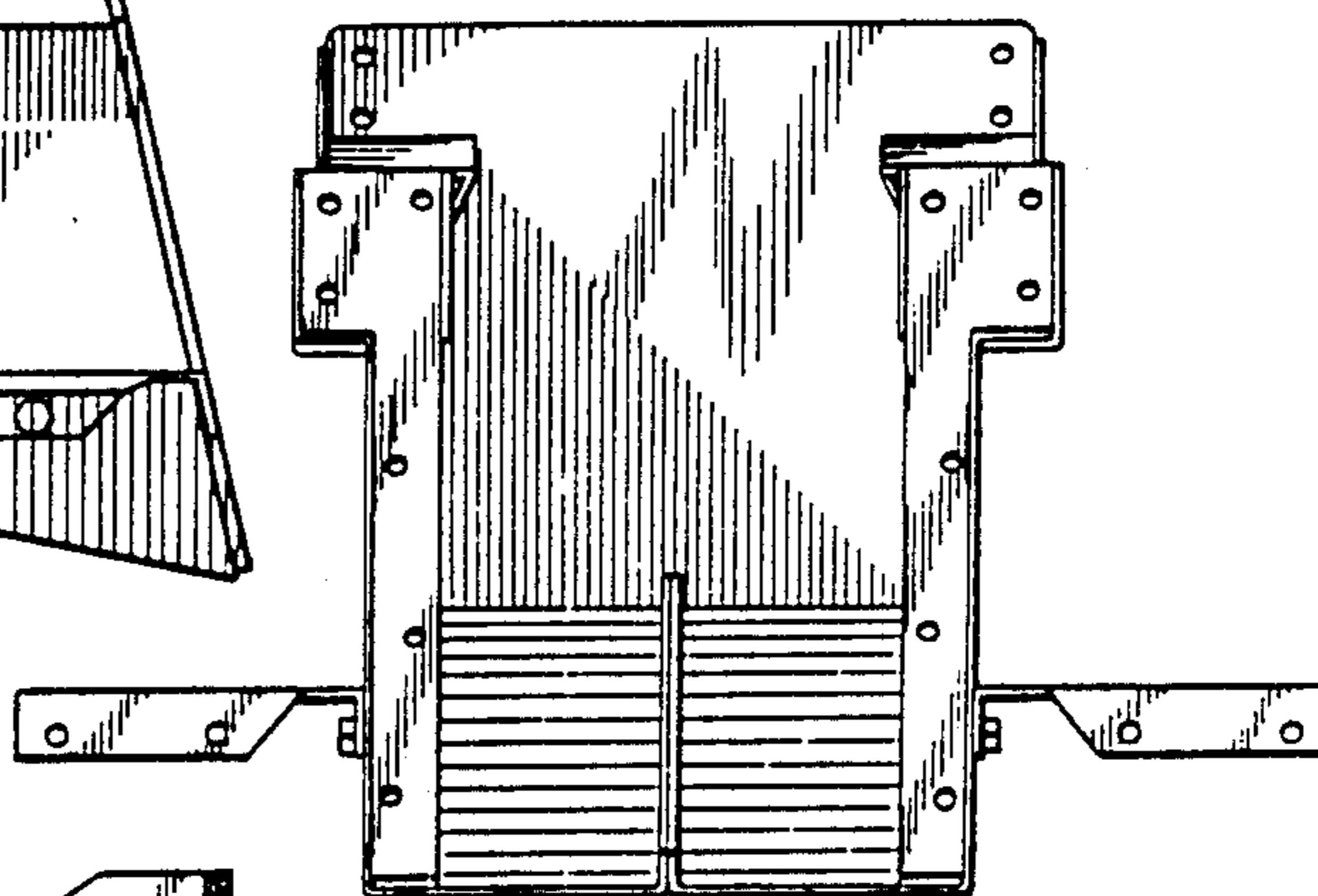

FIG. 18

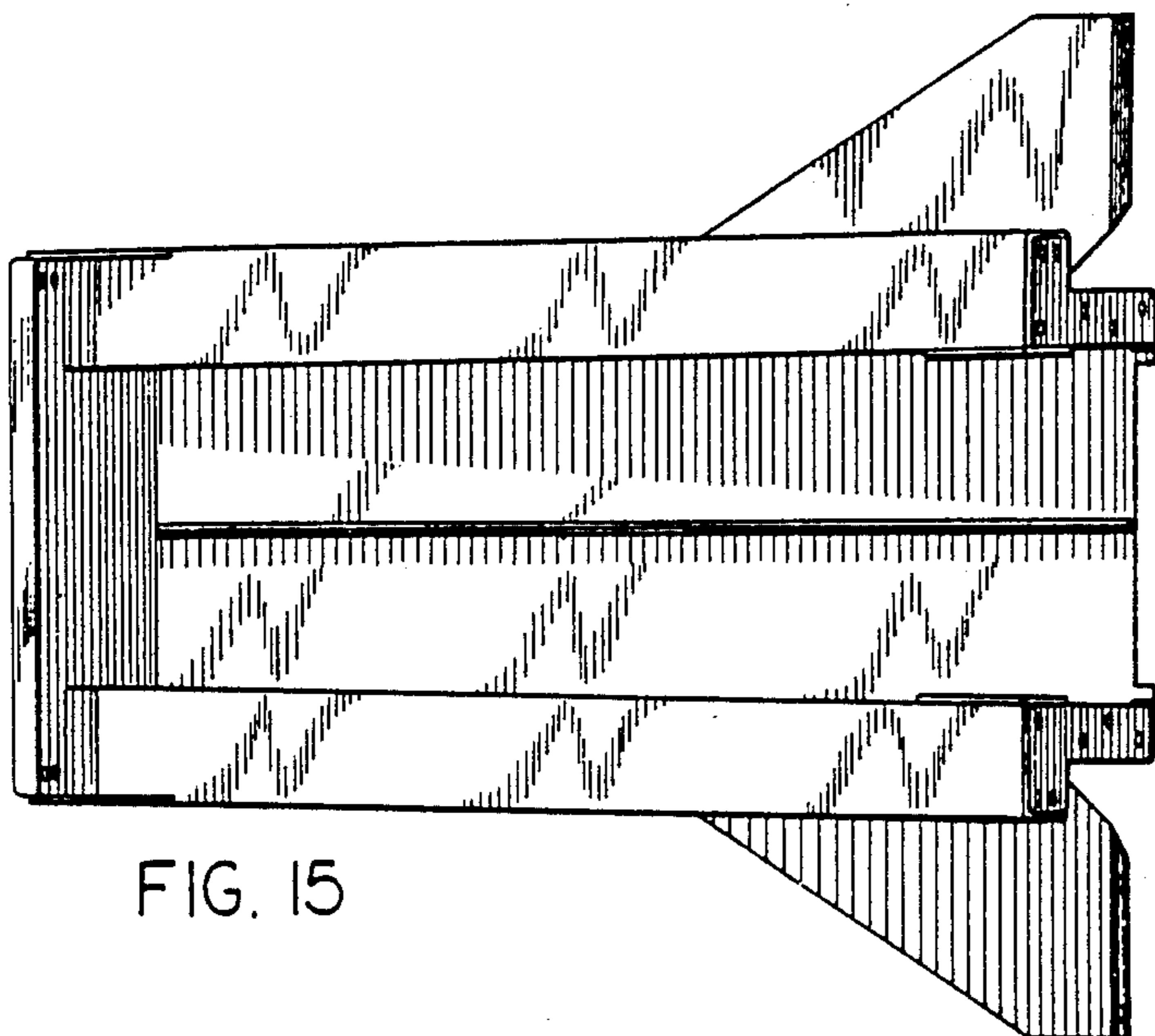

FIG. 15

