

[54] AUTO KNAPSACK

[76] Inventor: Joan K. Scott-Smith, 91 Ashuelot St., Dalton, Mass. 01226

[**] Term: 14 Years

[21] Appl. No.: 619,628

[22] Filed: Jun. 11, 1984

[52] U.S. Cl. D3/40; D3/32

[58] Field of Search D3/30.1, 31, 40, 32, D3/74; 224/275, 47.46, 47.42, 209, 259; 297/191; D2/226-229

[56] References Cited

U.S. PATENT DOCUMENTS

- D. 154,993 8/1949 Crothers D6/553
- D. 271,917 12/1983 Magis D3/40
- 2,767,895 10/1956 Smith D3/40
- 3,014,759 12/1961 Bing 224/275
- 3,987,946 10/1976 Haglof 224/275

FOREIGN PATENT DOCUMENTS

7311872 3/1975 Netherlands 224/275

Primary Examiner—George P. Word
Attorney, Agent, or Firm—Donald S. Holland

[57] CLAIM

The ornamental design for an auto knapsack, as shown and described.

DESCRIPTION

FIG. 1 is a front perspective view of an auto knapsack showing my new design;
 FIG. 2 is an enlarged scale right side elevational view thereof;
 FIG. 3 is a rear perspective view thereof; and
 FIG. 4 is a reduced scale front perspective view thereof shown attached to the rear of a car seat.
 The car seat shown in dotted lines in FIG. 4 is for illustrative purposes only and not a part of the design sought to be patented.

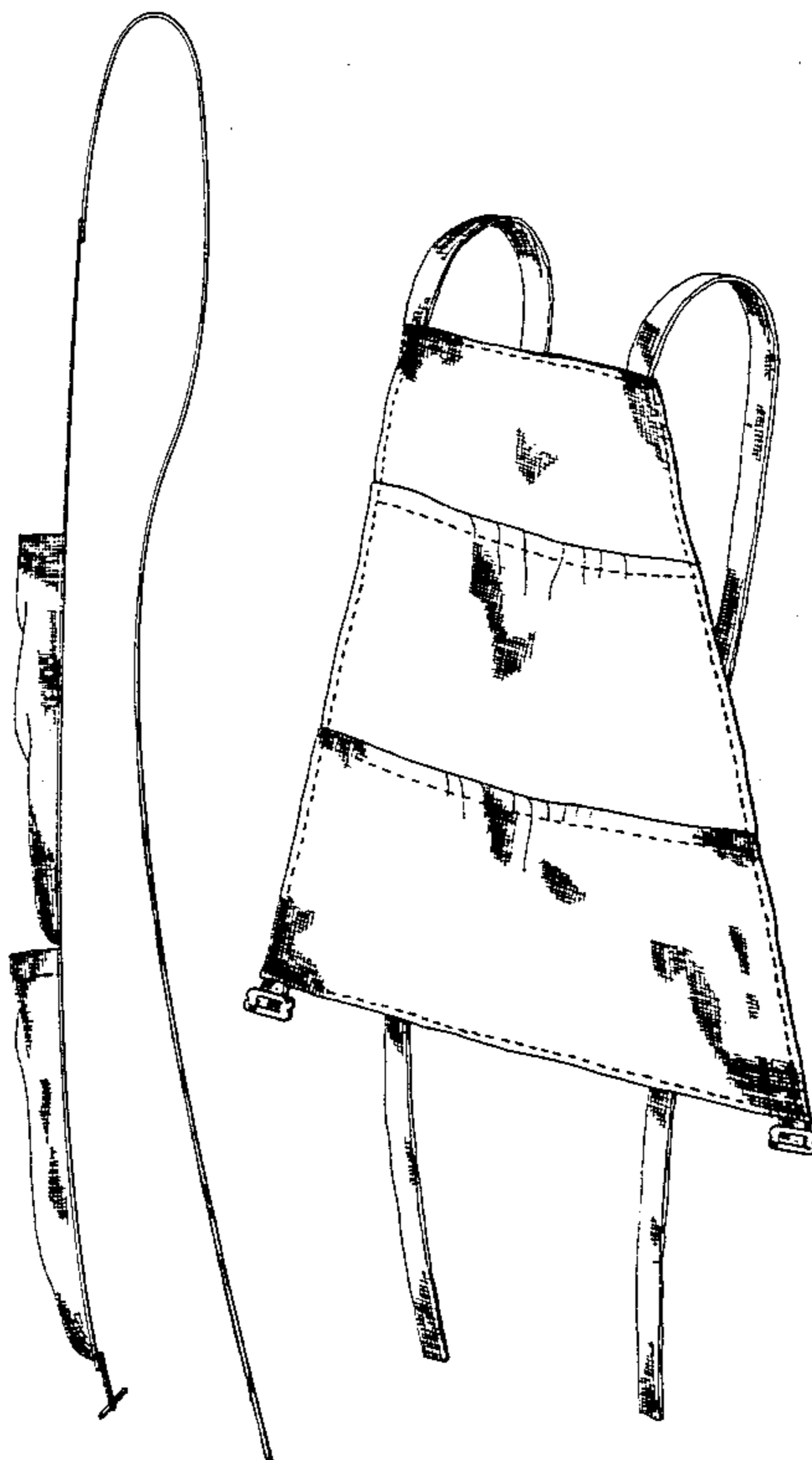

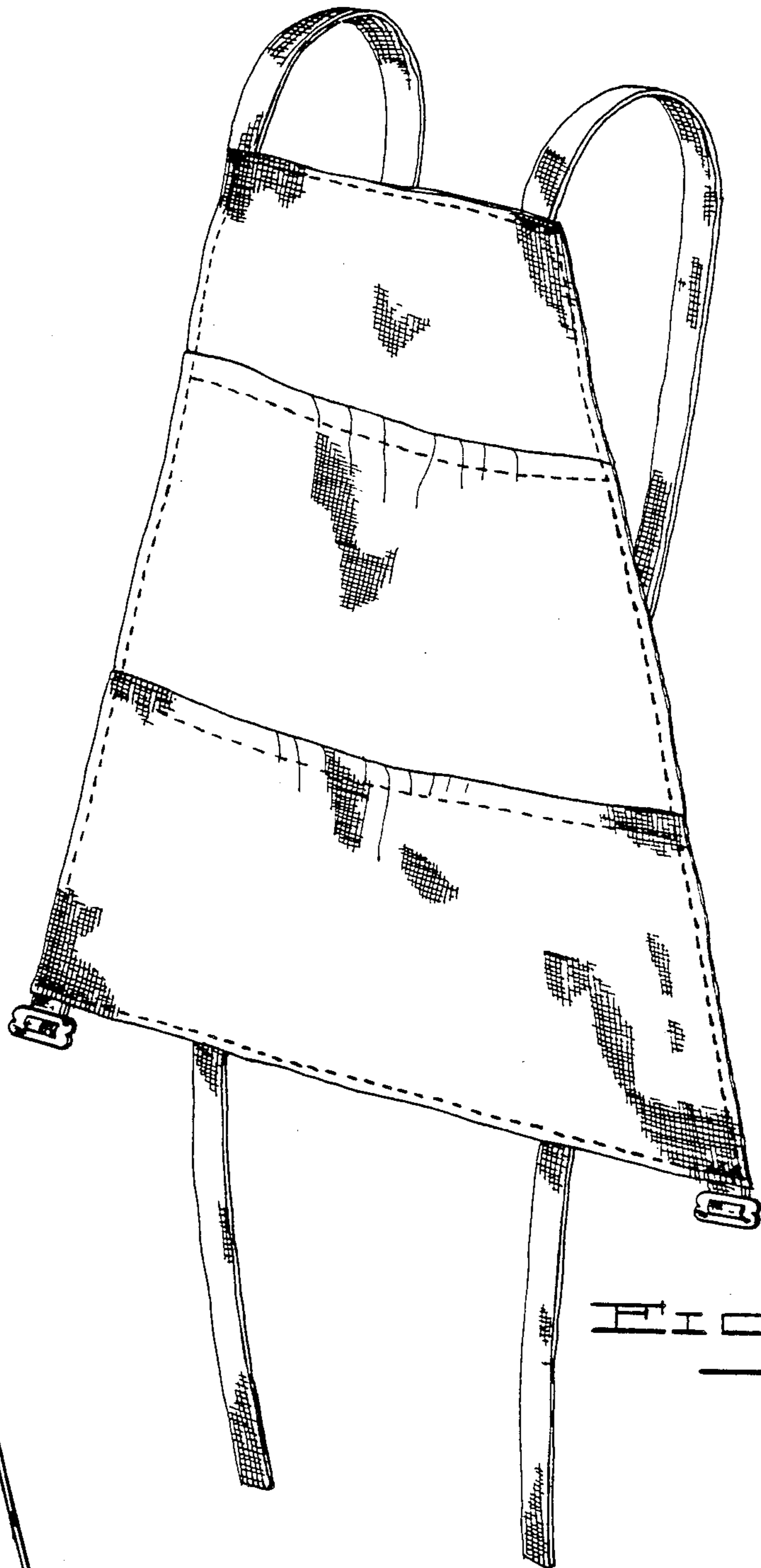
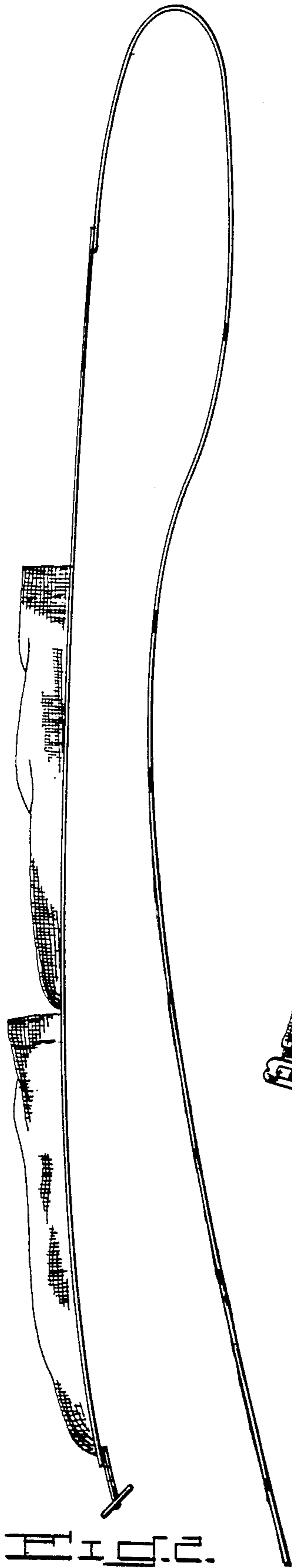

FIG. 1.

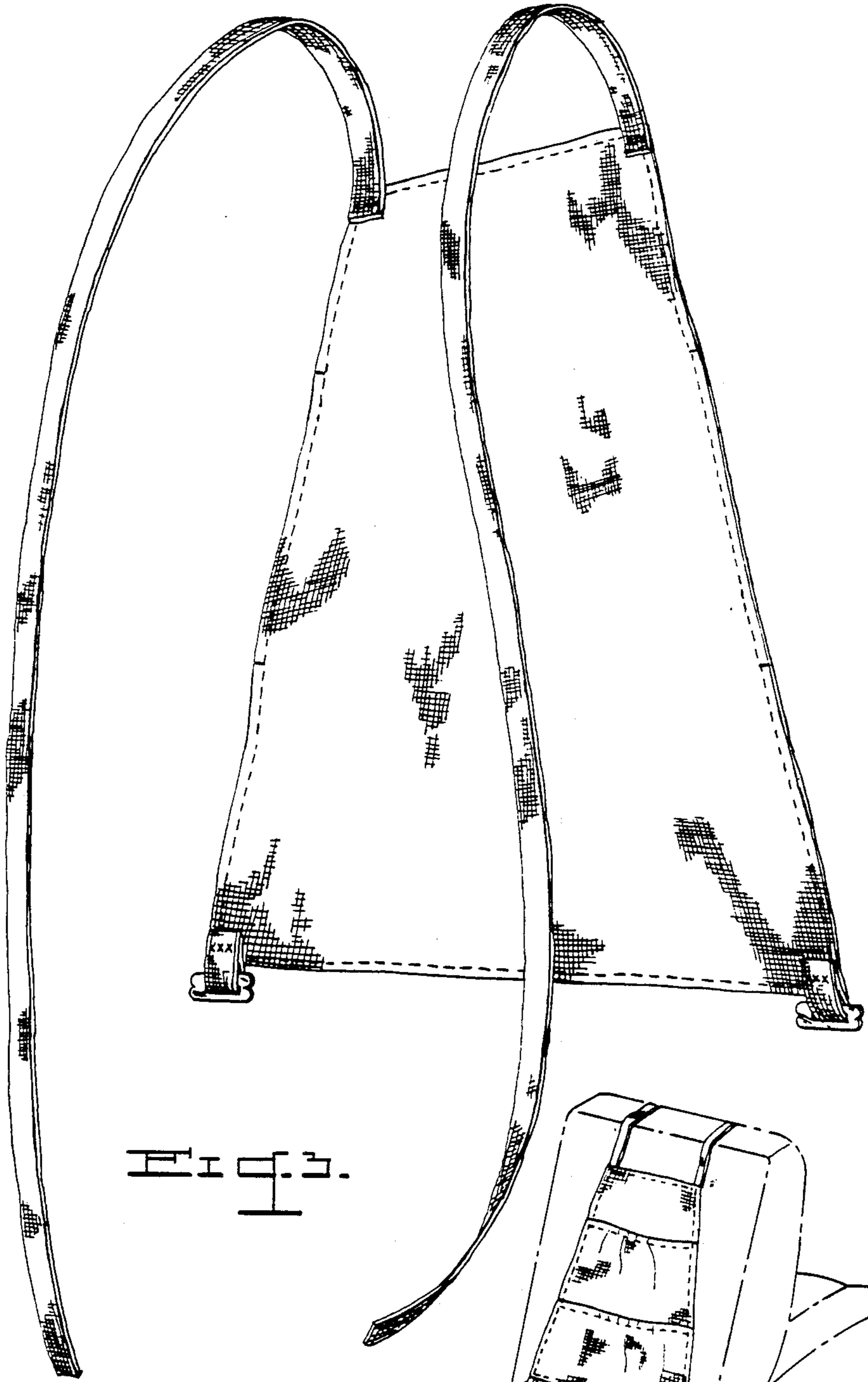

Fig. 3.

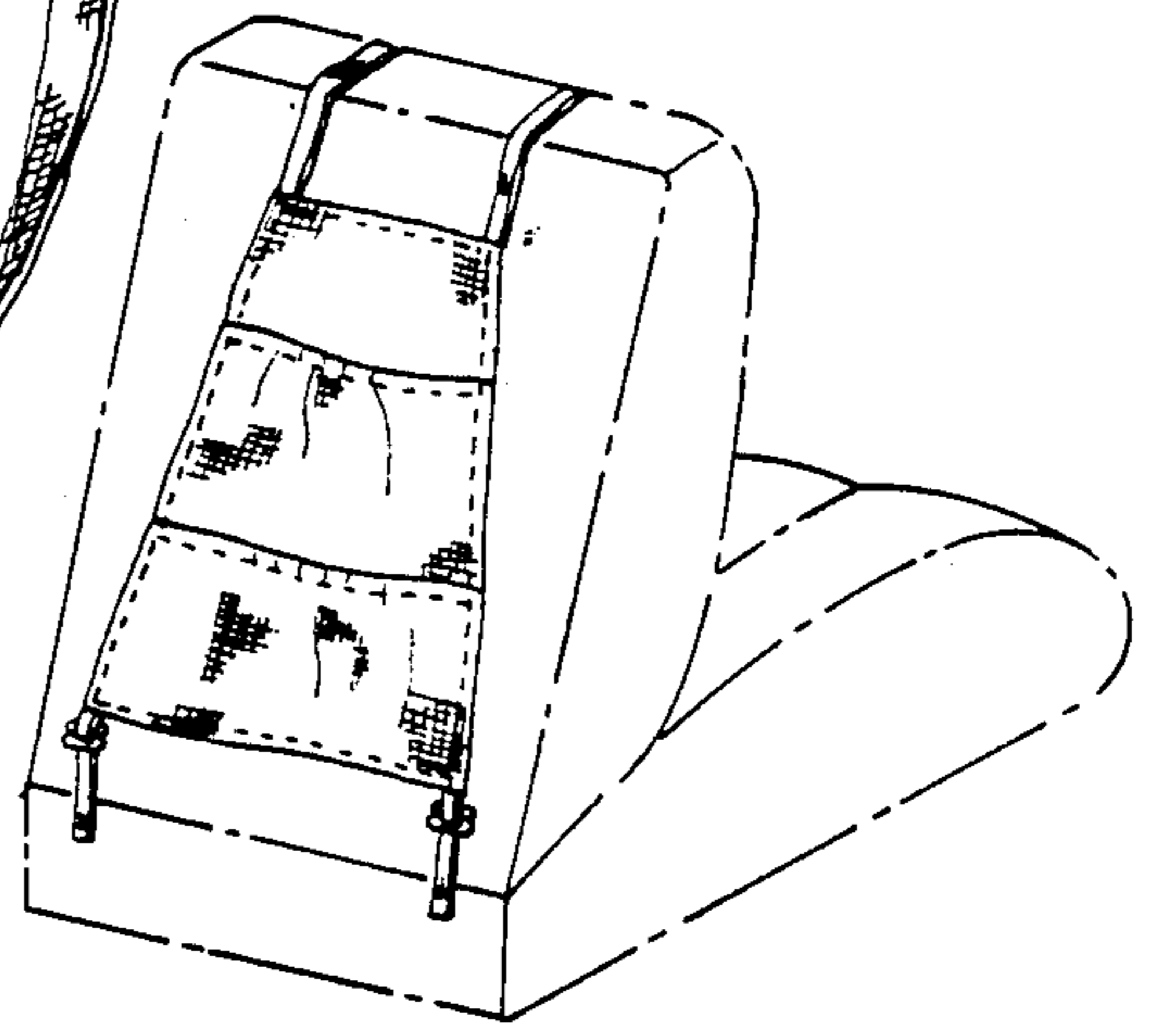

Fig. 4.