

[54] VEHICLE WHEEL CENTER

[75] Inventor: Charles E. Steele, Battle Creek, Mich.

[73] Assignee: Kelsey-Hayes Company, Romulus, Mich.

[**] Term: 14 Years

[21] Appl. No.: 715,220

[22] Filed: Mar. 22, 1985

[52] U.S. Cl. D12/211

[58] Field of Search D12/209, 211; 301/37 R, 301/63 R, 64 R, 64 SD, 65

[56] References Cited

PUBLICATIONS

Road & Track, 6/74, p. 71, Wheel of Bertone's Alfasud Caimano, top of page.
1984 Mazda catalog, p. 7, wheel of Mazda 626.

Primary Examiner—James M. Gandy
Attorney, Agent, or Firm—Ralph J. Skinkiss; David L. Kuhn

[57] CLAIM

The ornamental design for a vehicle wheel center, as shown and described.

DESCRIPTION

FIG. 1 is a left, front perspective view of a vehicle wheel center showing my new design.

FIG. 2 is a front elevational view thereof.

FIG. 3 is a sectional view taken along line 3—3 in FIG. 2.

FIG. 4 is a sectional view taken along line 4—4 in FIG. 2.

FIG. 5 is a sectional view taken along line 5—5 in FIG. 2.

The broken lines in the drawing are for illustrative purposes only and form no part of the claimed design.

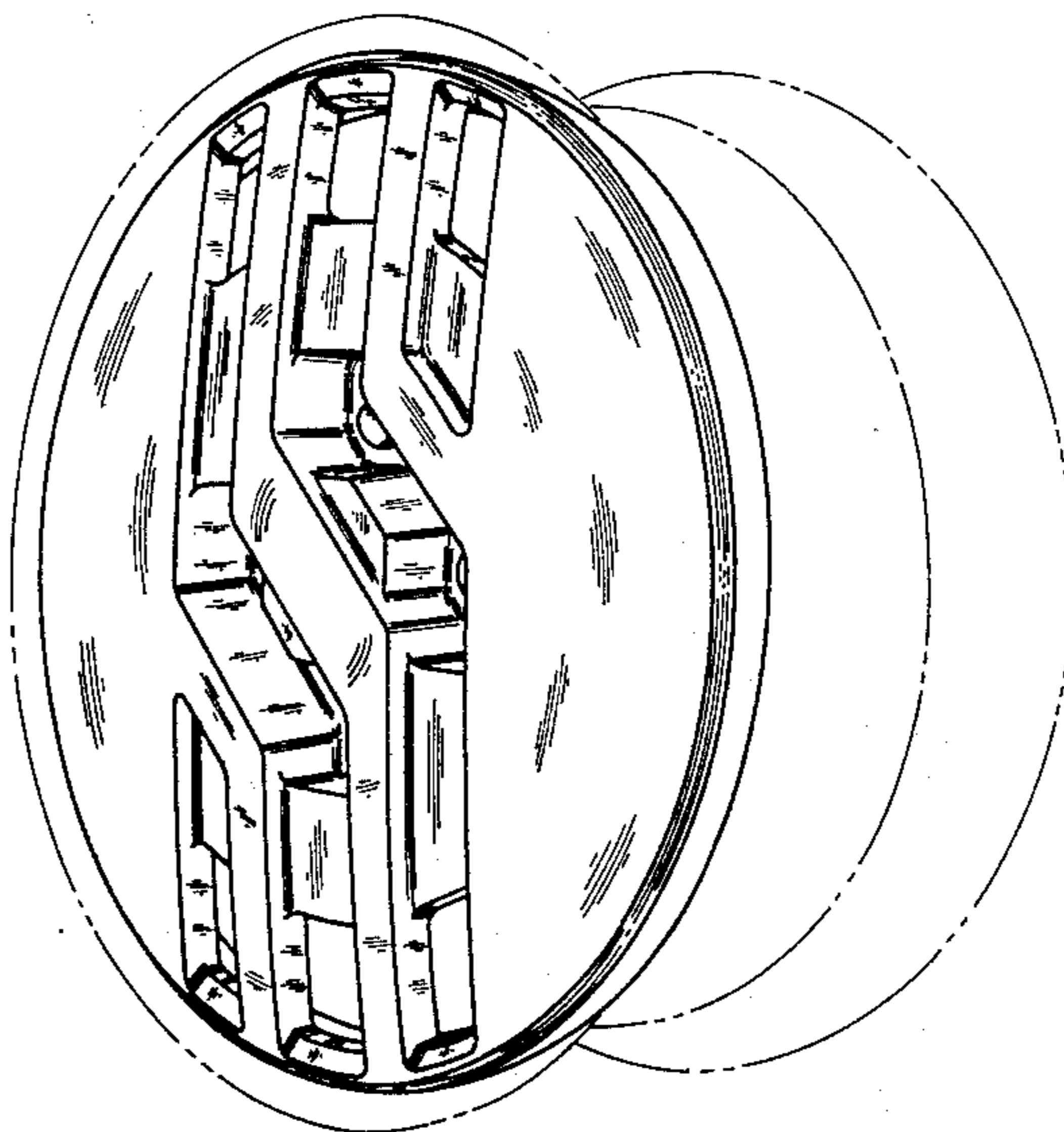

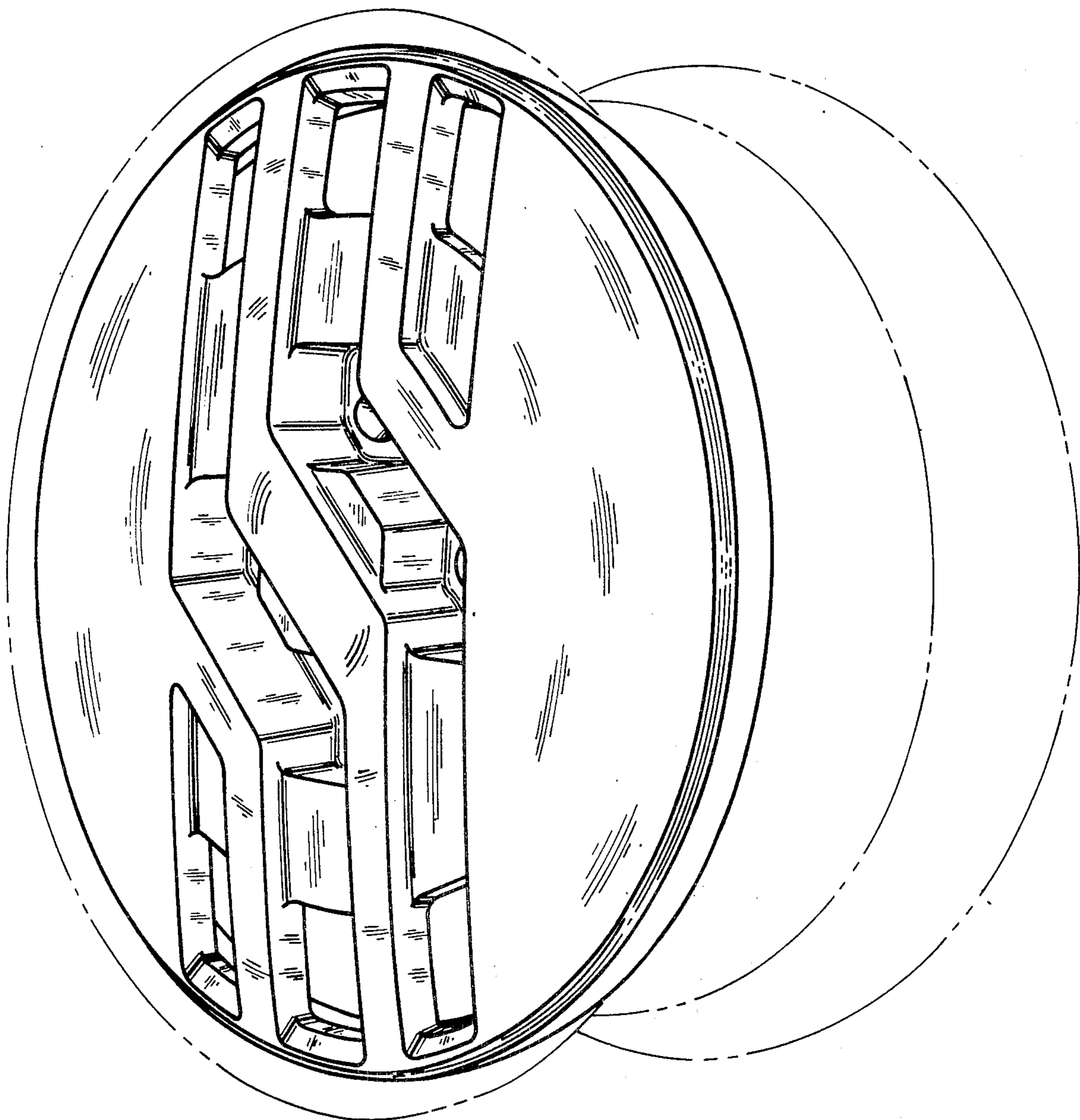

—FIG. 1

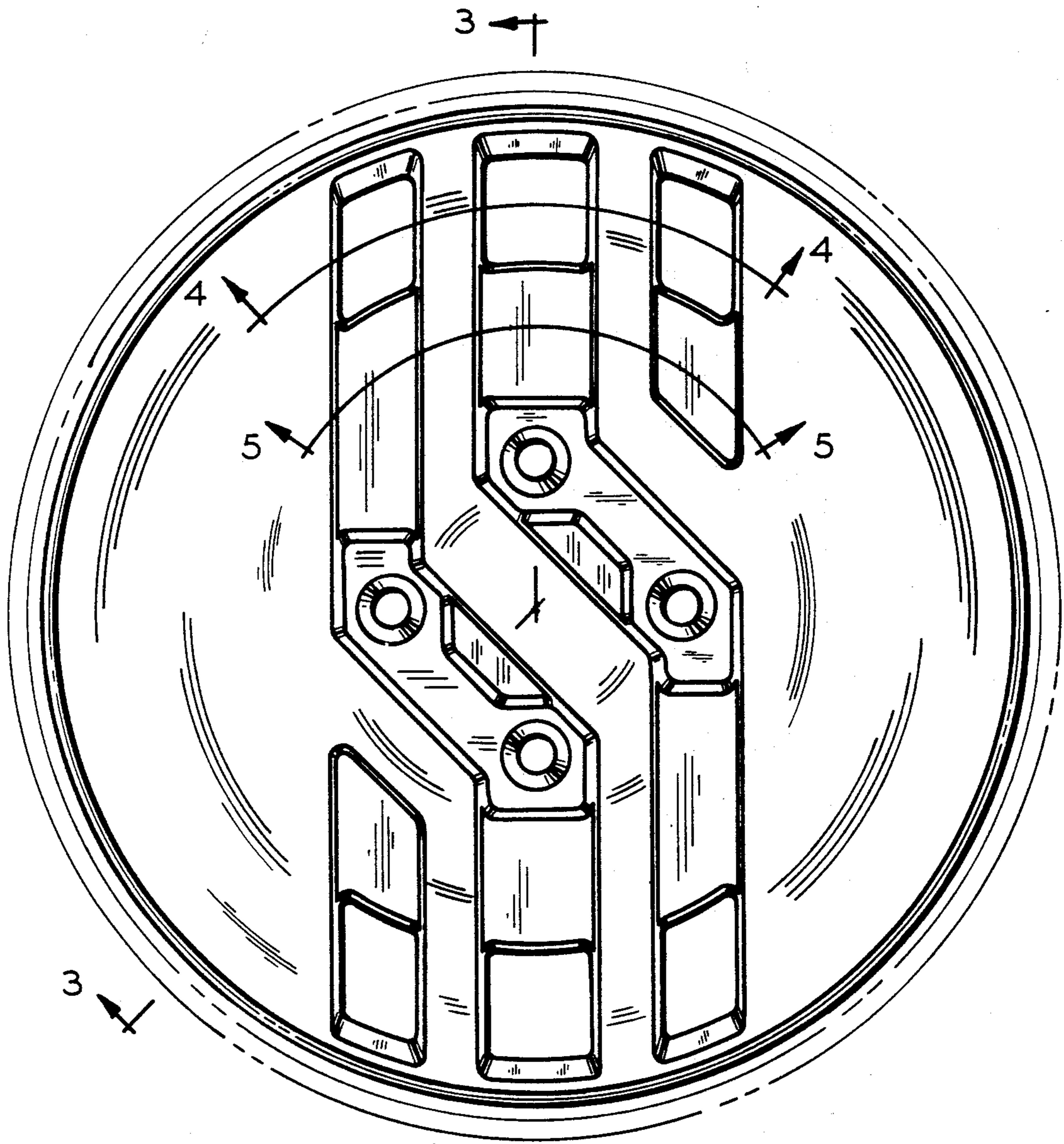

—FIG. 2

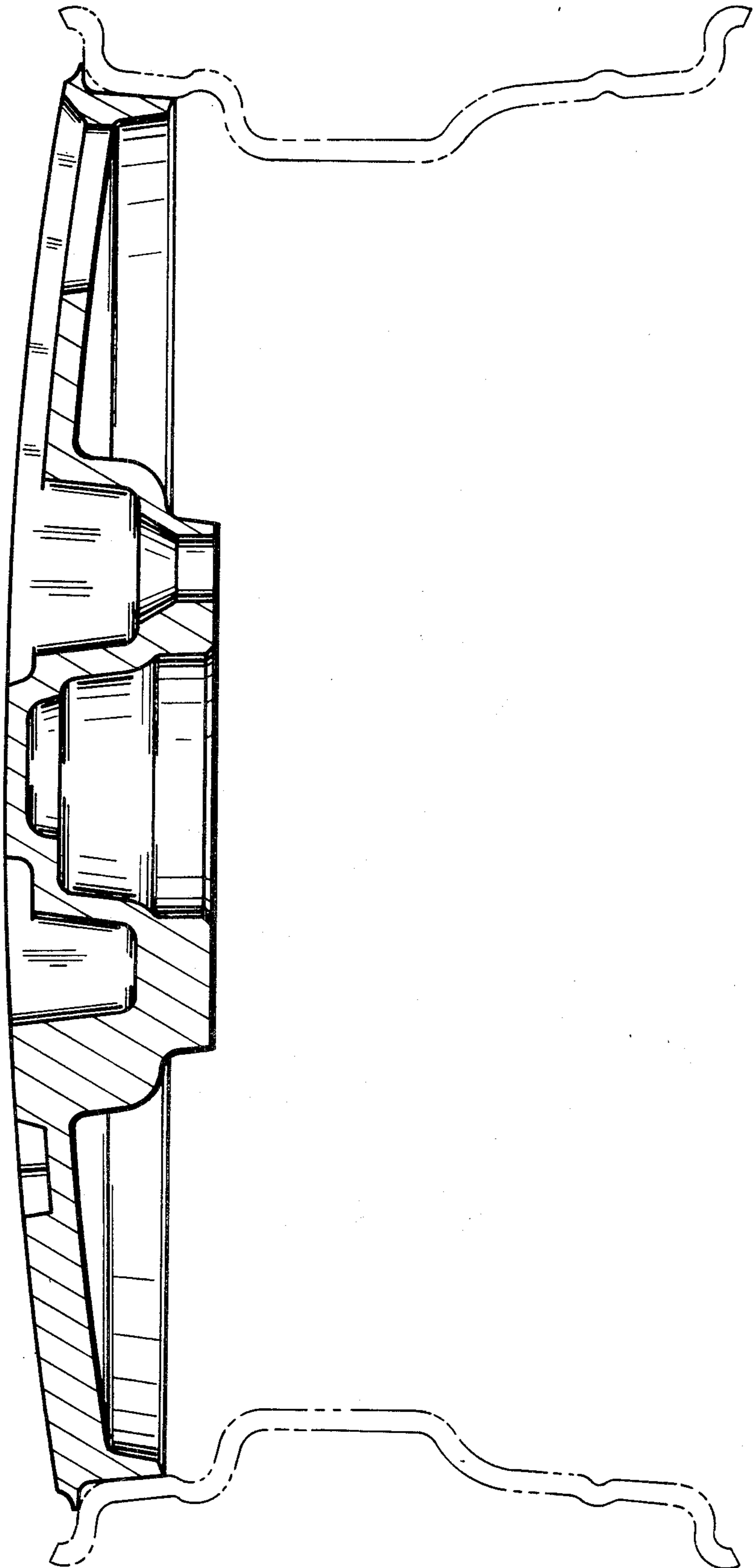
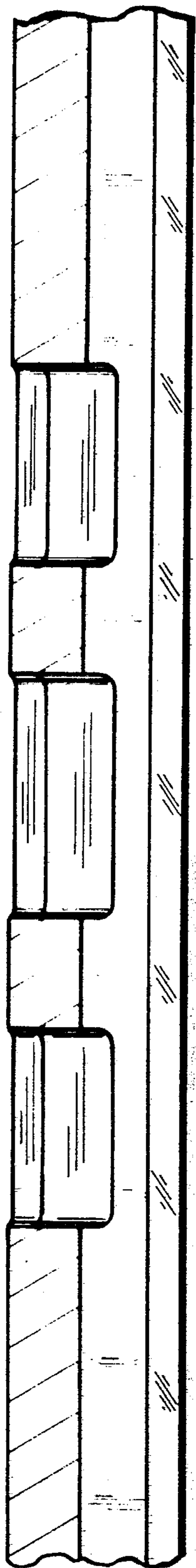
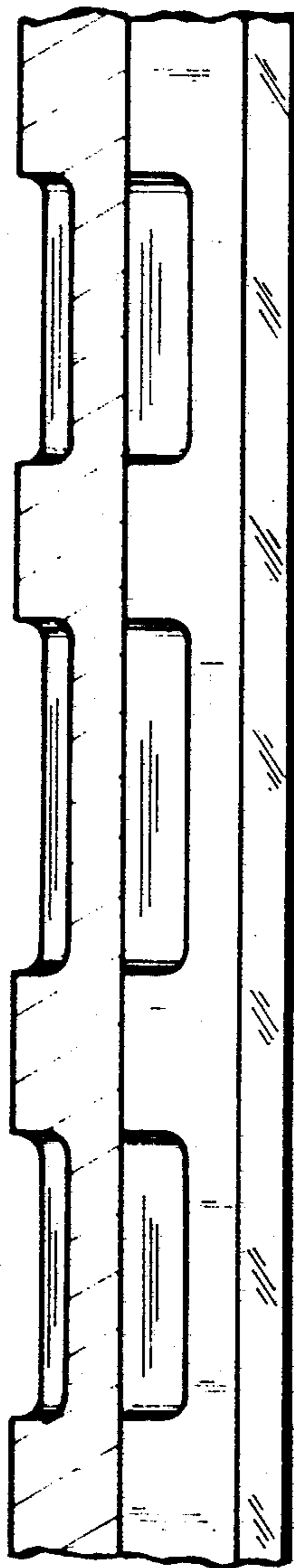

FIG. 3



— FIG. 4



— FIG. 5