

[54] VEHICLE WHEEL CENTER

[75] Inventor: Donald J. Reid, Plymouth, Mich.

[73] Assignee: Kelsey-Hayes Company, Romulus, Mich.

[**] Term: 14 Years

[21] Appl. No.: 764,826

[22] Filed: Aug. 12, 1985

[52] U.S. Cl. D12/211

[58] Field of Search D12/209, 211; 301/87 R, 301/63 R, 64 R, 64 SD, 65

[56] References Cited

U.S. PATENT DOCUMENTS

D. 209,196	11/1967	Main et al.	D12/211
D. 235,433	6/1975	May et al.	D12/211
D. 256,455	8/1980	Wolff	D12/211
D. 267,564	1/1983	Wright	D12/211

Primary Examiner—James M. Gandy
Attorney, Agent, or Firm—Ralph J. Skinkiss; David L. Kuhn

[57] CLAIM

The ornamental design for a vehicle wheel center, as shown and described.

DESCRIPTION

FIG. 1 is a front elevational view of a vehicle wheel center showing my new design.

FIG. 2 is a sectional view taken along line 2—2 in FIG. 1.

FIG. 3 is a sectional view taken along line 3—3 in FIG. 1.

FIG. 4 is a sectional view taken along line 4—4 in FIG. 1.

FIG. 5 is a sectional view taken along line 5—5 in FIG. 1.

The broken lines in the drawing are for illustrative purposes only and form no part of the claimed design.

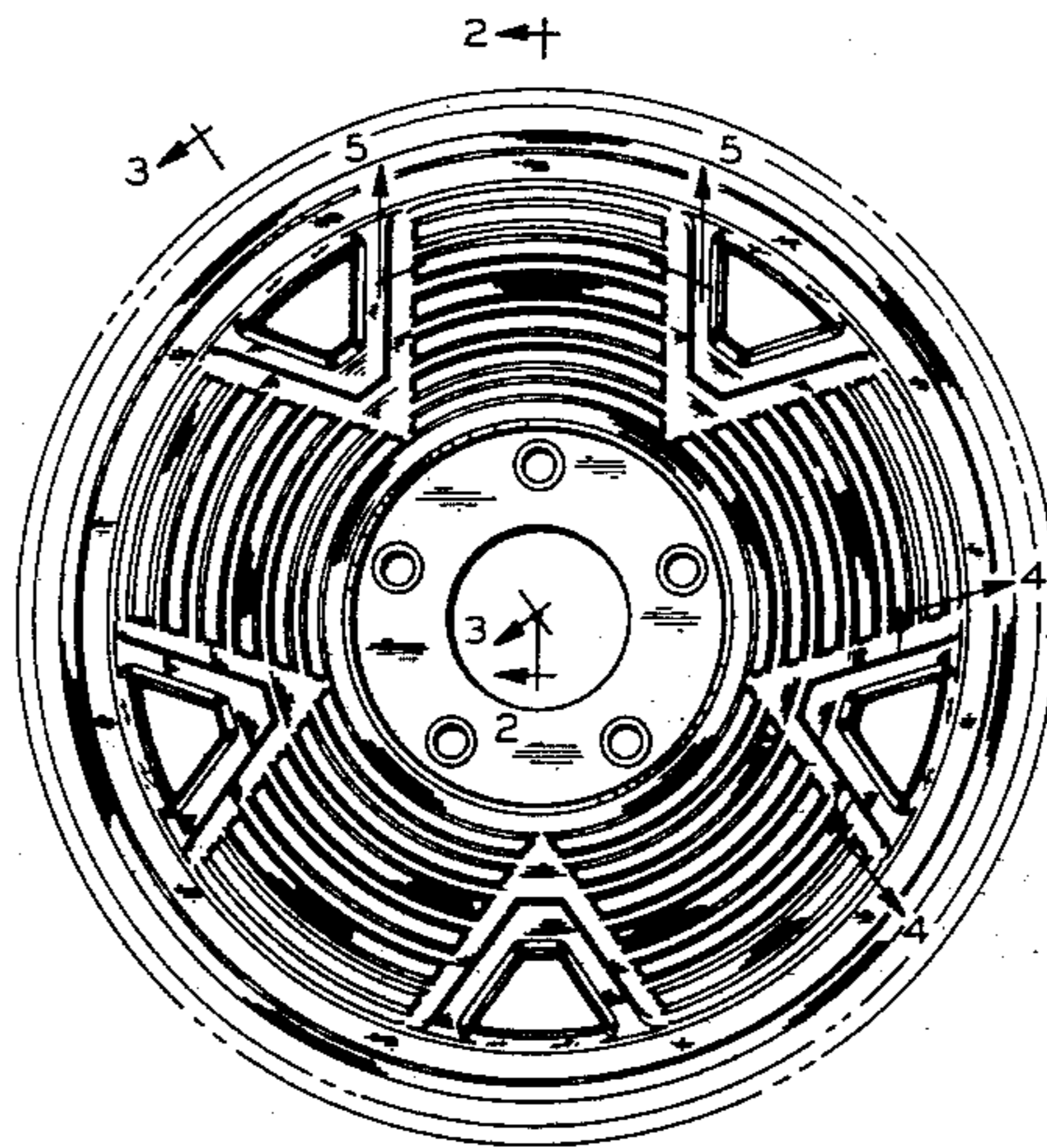

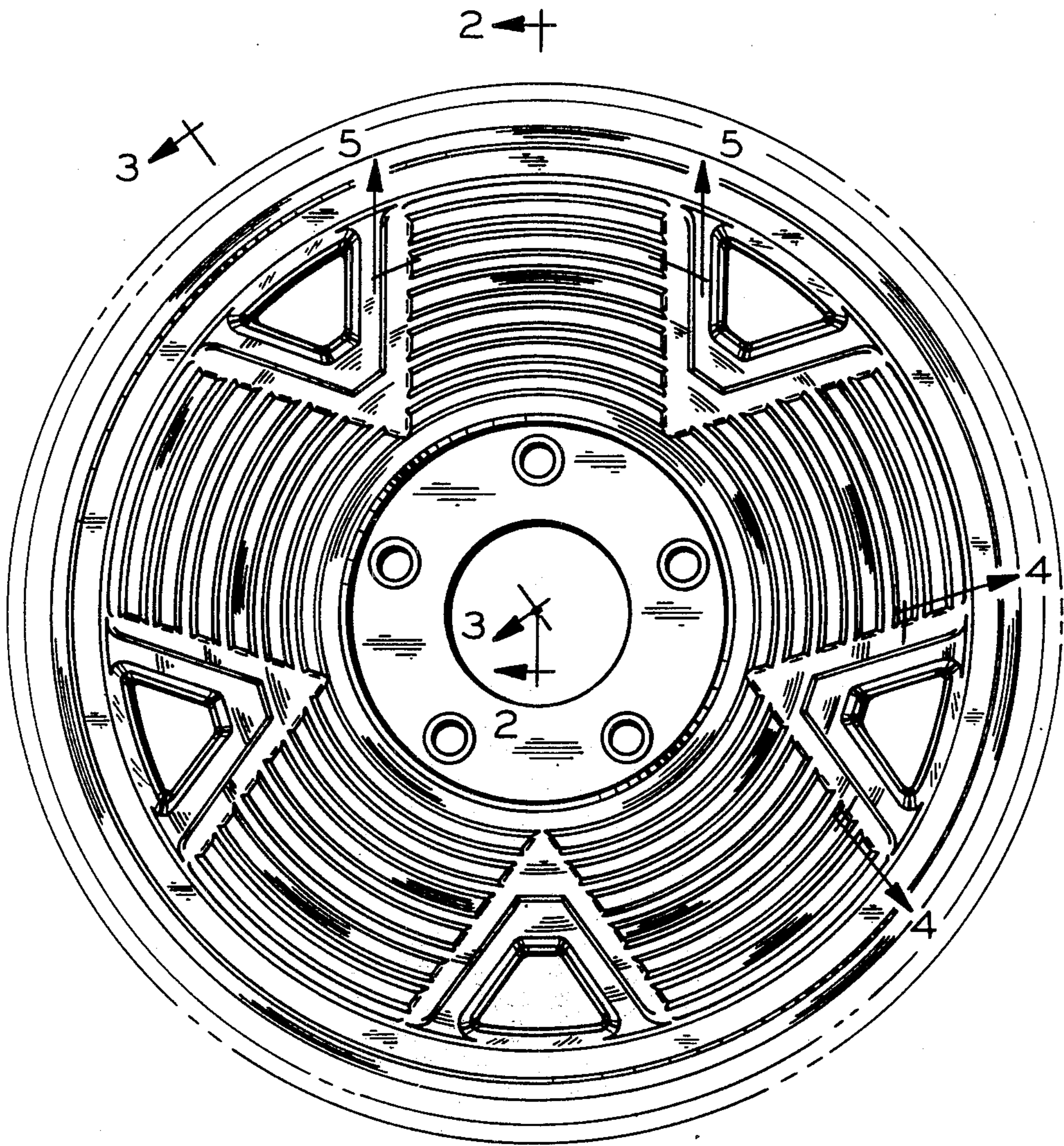

— FIG. 1

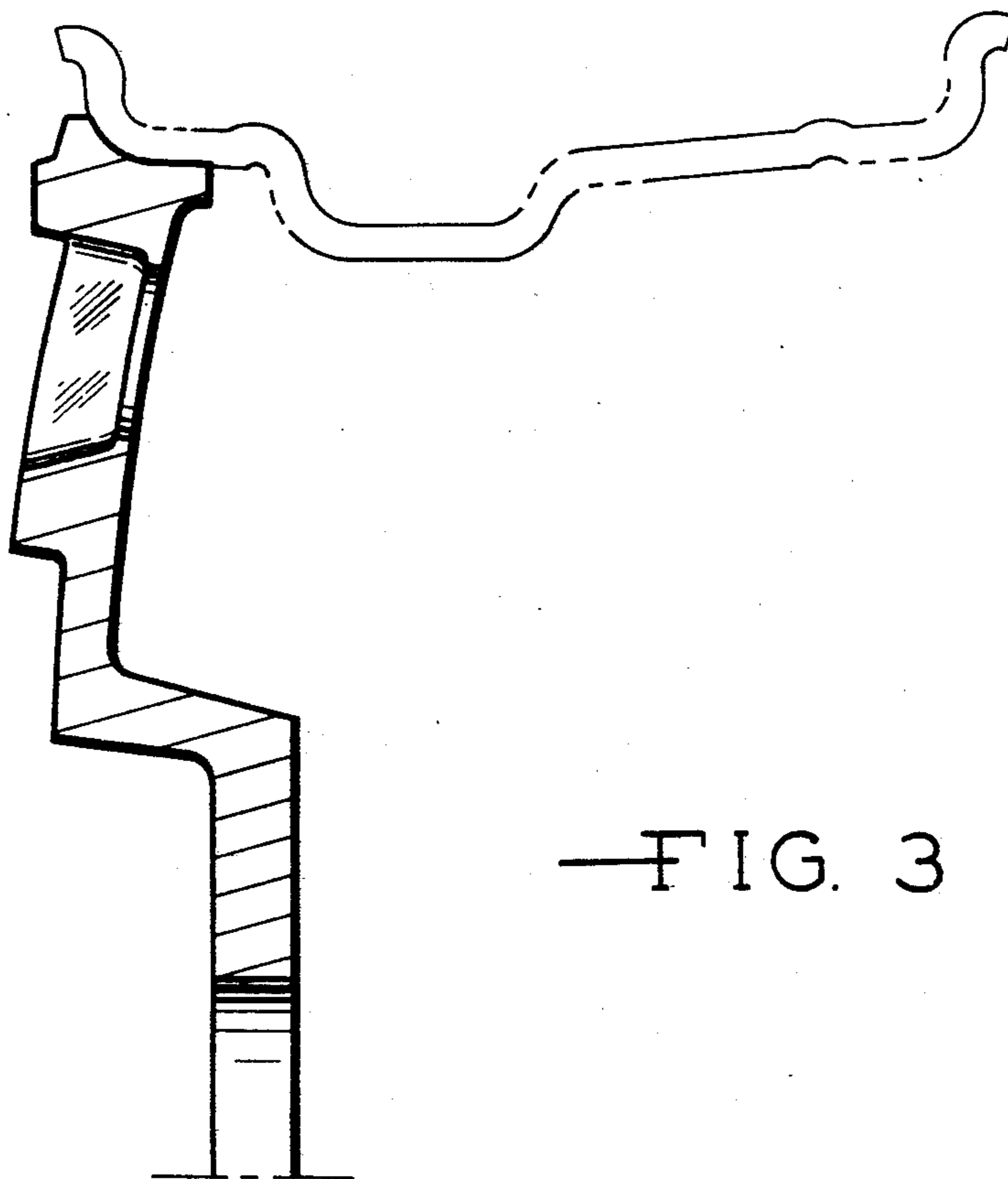
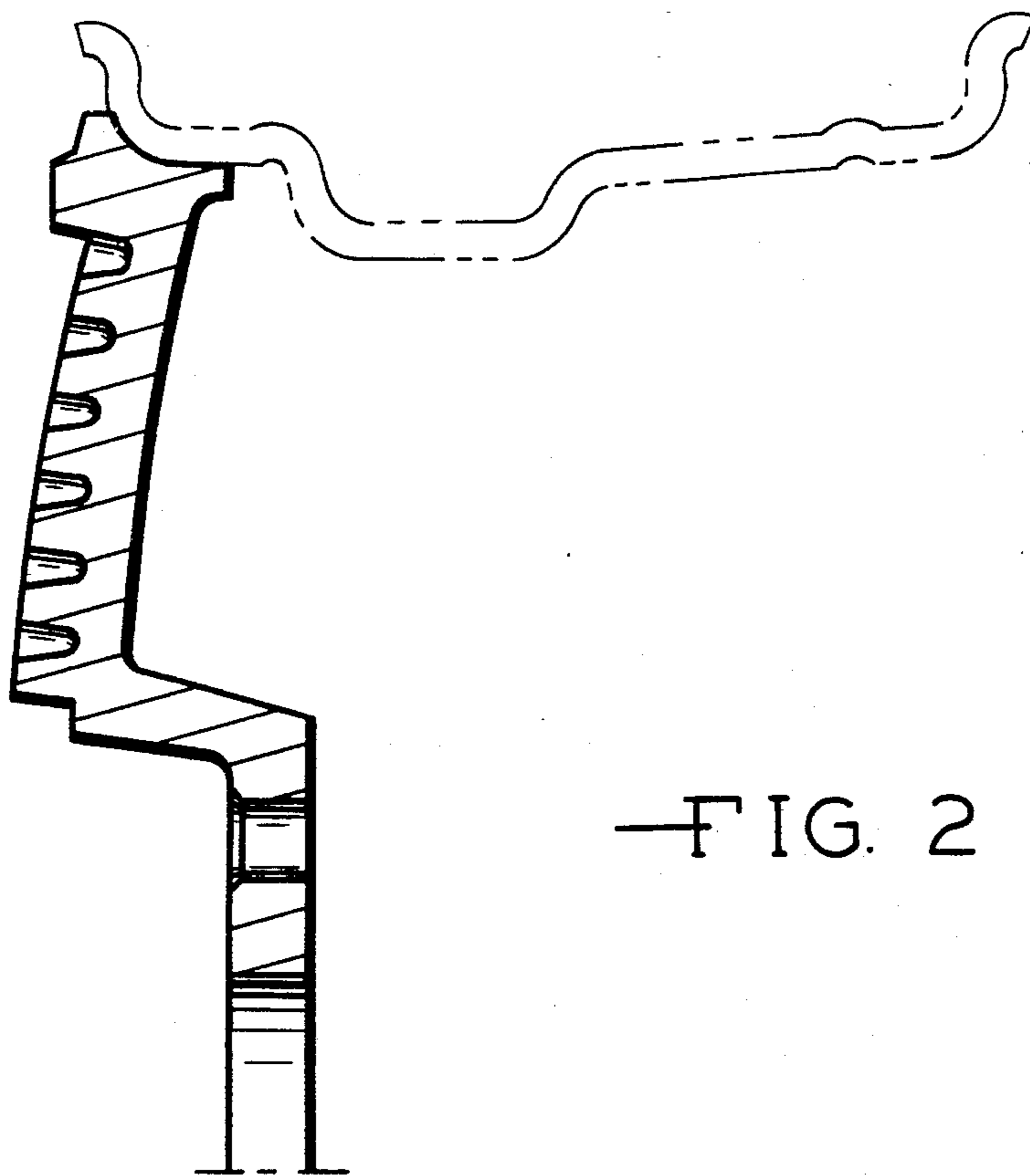

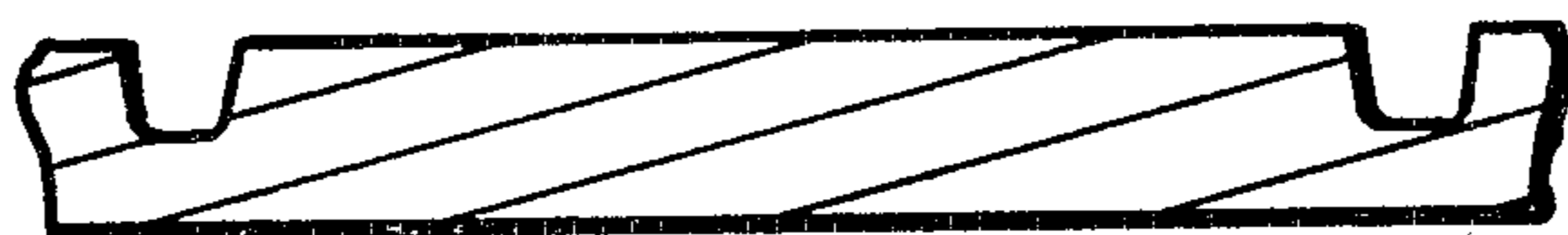

FIG. 5



FIG. 4