

[54] COMBINED HELICOPTER AND TANK

[76] Inventor: Anis I. Milad, 29-38 Yorkway, Baltimore, Md. 21222

[**] Term: 14 Years

[21] Appl. No.: 690,587

[22] Filed: Jan. 11, 1985

[52] U.S. Cl. D12/2; D21/90; D21/131

[58] Field of Search D21/131, 85; D12/214, D12/12; 446/230, 37, 237, 433, 465; 244/1 R, 2, 17.11, 17.17

[56] References Cited

U.S. PATENT DOCUMENTS

D. 135,849	6/1943	Gibson	D21/131
D. 138,329	7/1944	Wasson	D21/85
D. 169,229	3/1953	Tober	D21/131
D. 284,594	7/1986	Fisher	D21/85
D. 287,378	12/1986	Ohno	D21/131

1,788,440	1/1931	Prell	.
2,019,482	11/1935	Barnes	.
2,424,769	7/1947	Page	.
2,560,747	7/1951	Sievers	.
3,761,040	9/1973	Cummins	.

Primary Examiner—Charles A. Rademaker
Attorney, Agent, or Firm—Leonard Bloom

[57] CLAIM

The ornamental design for a combined helicopter and tank, as shown and described.

DESCRIPTION

FIG. 1 is a side elevational view of a combined helicopter and tank showing my new design, the side opposite being substantially a mirror image;
FIG. 2 is a top plan view thereof;
FIG. 3 is a bottom plan view thereof;
FIG. 4 is a front elevational view thereof; and,
FIG. 5 is a rear elevational view thereof.
Portions of the blade members have been shown in fragment in FIGS. 2 and 3 for ease of illustration.

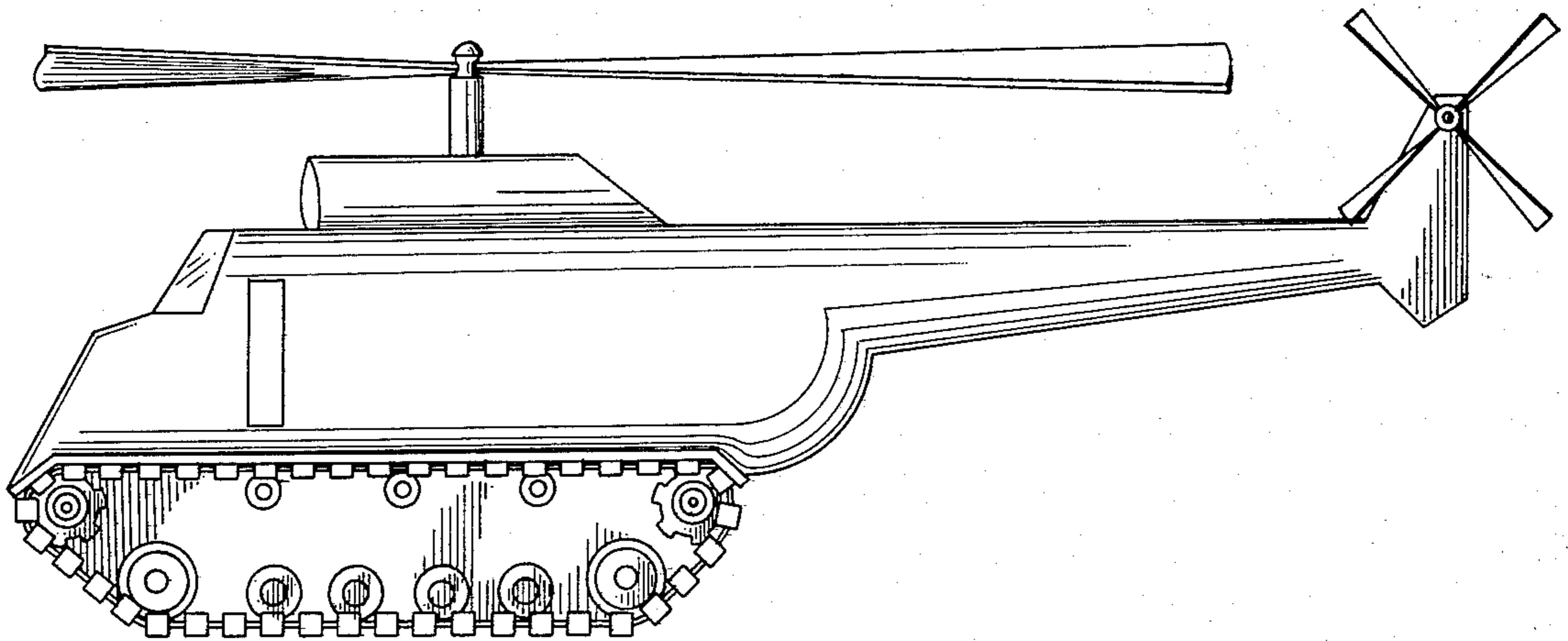

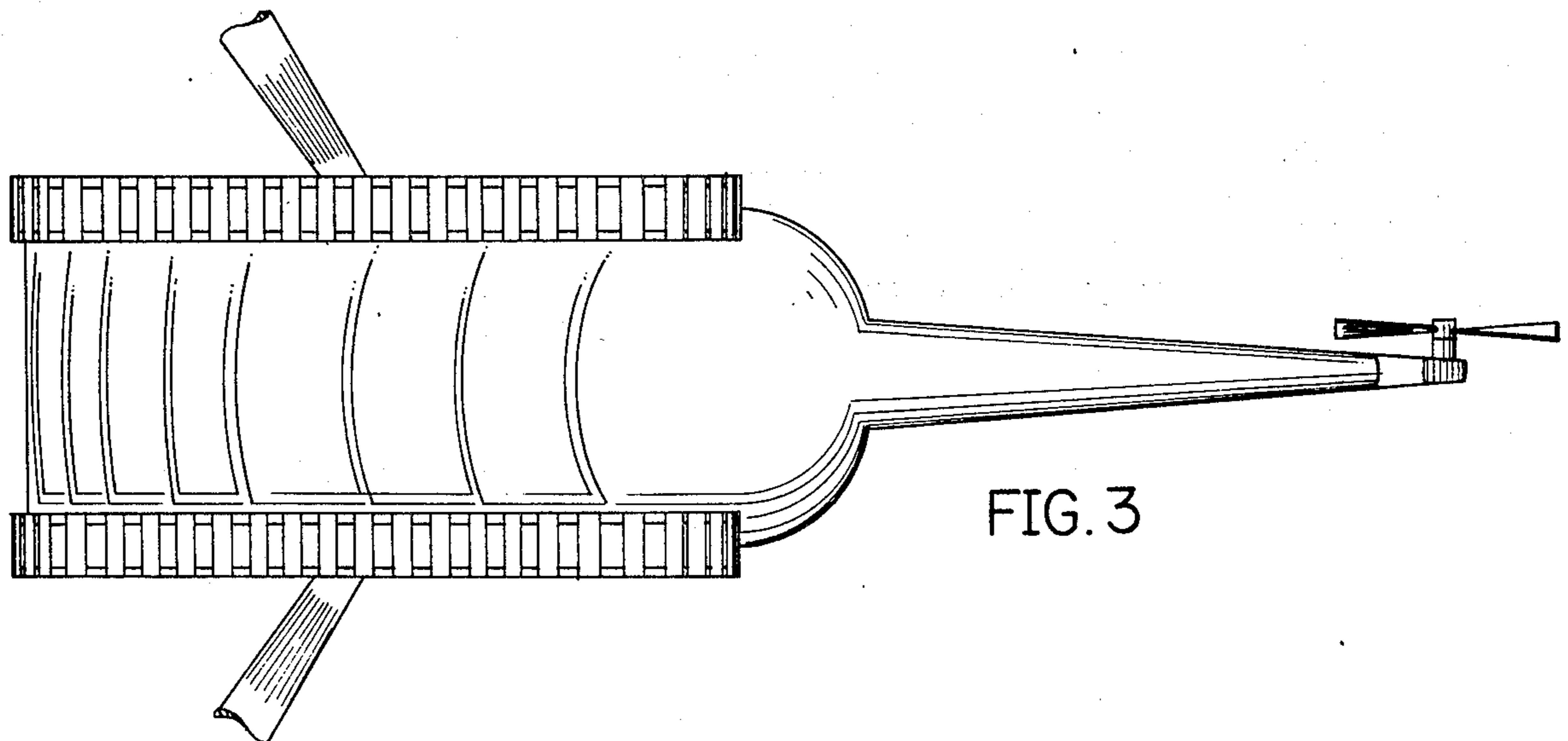
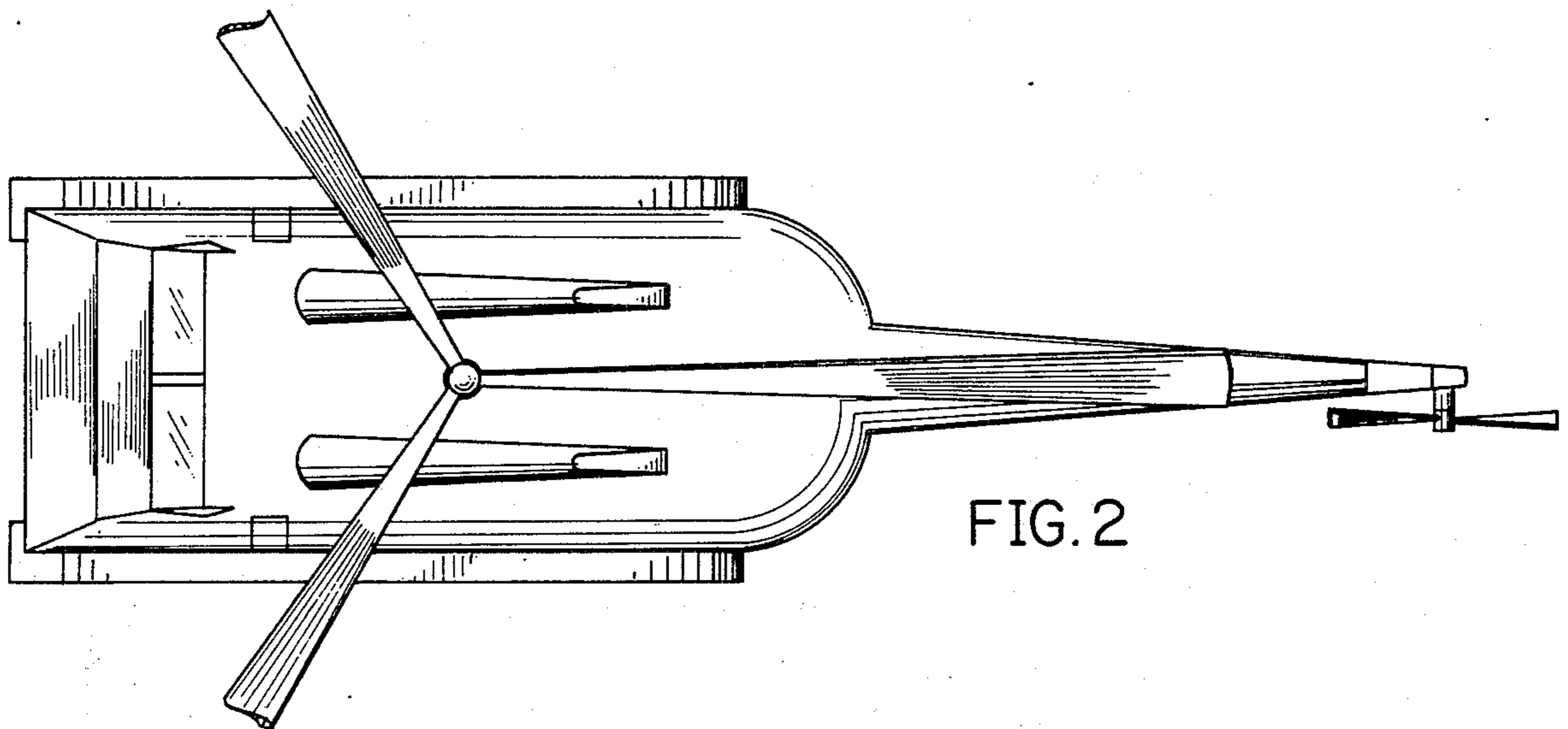
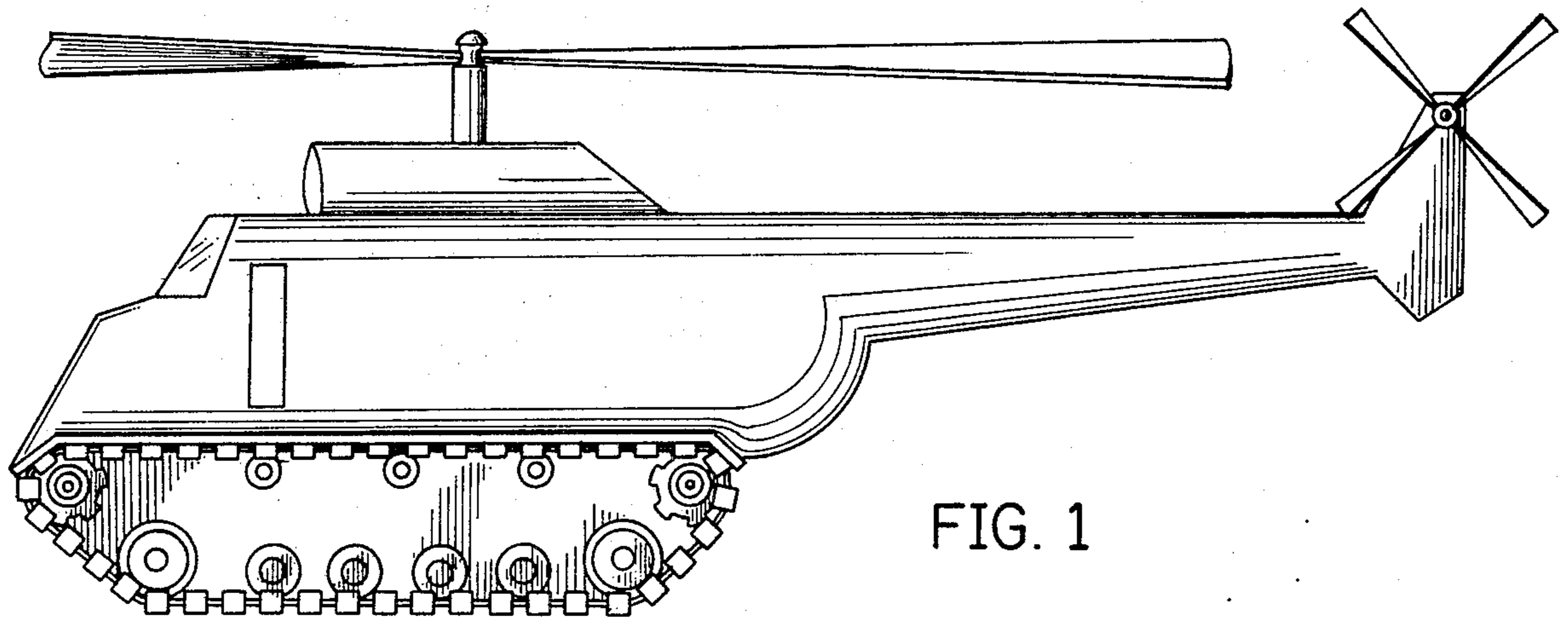

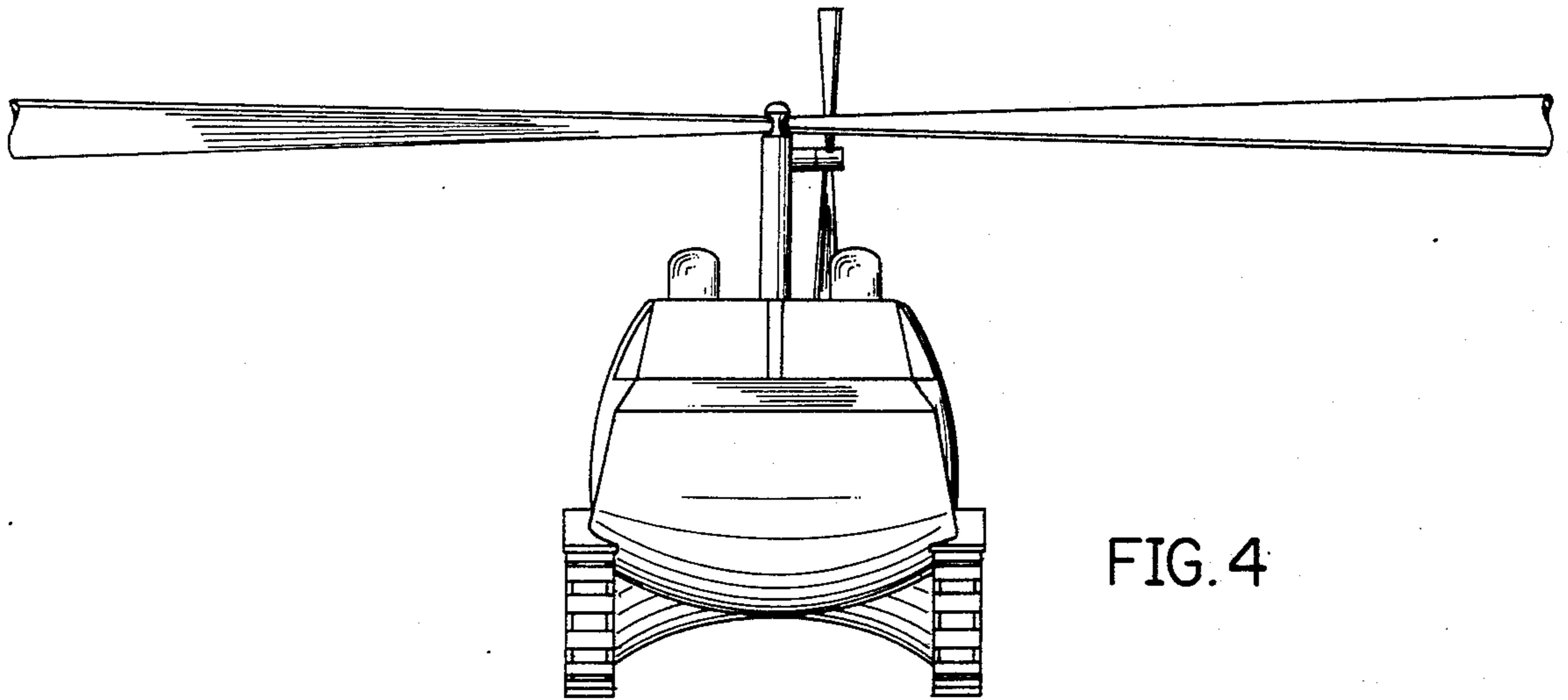

FIG. 4

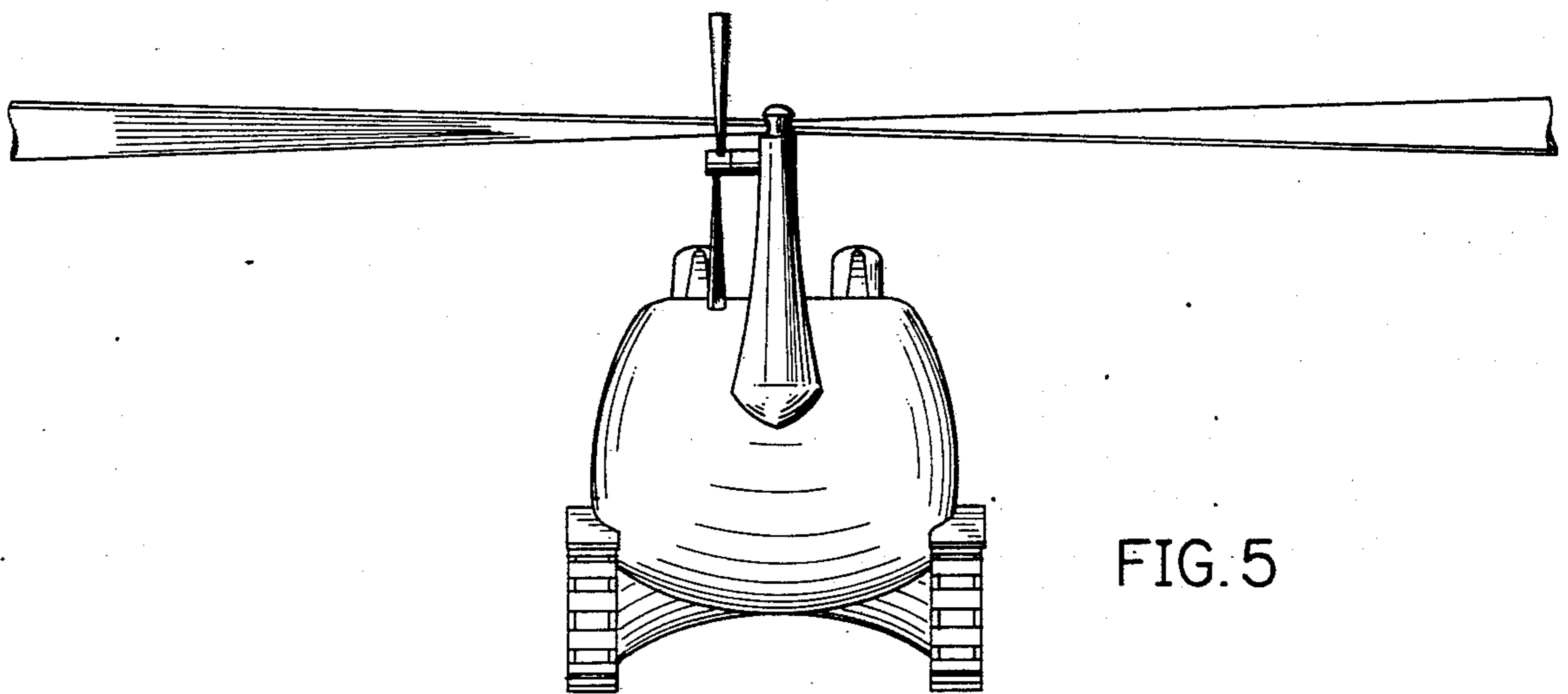

FIG. 5