

[54] WIRE TAP CONNECTOR

[75] Inventor: Sydney Bryant, Taree, Australia

[73] Assignee: Sydney, Bryant Manufacturing Pty. Ltd., New South Wales, Australia

[**] Term: 14 Years

[21] Appl. No.: 684,142

[22] Filed: Dec. 20, 1984

[52] U.S. Cl. D13/24; D13/13

[58] Field of Search D13/11, 24-31; 339/97 P, 98, 99 R, 196 R, 196 A, 196 M

[56] References Cited

U.S. PATENT DOCUMENTS

3,576,518	4/1971	Bazille, Jr.	339/98
3,899,236	8/1975	Santos	339/98
3,920,305	11/1975	Scott	339/98
4,047,784	9/1977	Trank	339/98

OTHER PUBLICATIONS

J. C. Whitney Automotive Tool Catalog, p. 36, Wire Splice Connectors.

Primary Examiner—Susan J. Lucas
Assistant Examiner—C. E. Heflin
Attorney, Agent, or Firm—Schwartz, Jeffery, Schwaab, Mack, Blumenthal & Evans

[57] CLAIM

The ornamental design for a wire tap connector, as shown and described.

DESCRIPTION

FIG. 1 is a perspective view of the wire tap connector showing my new design in the open position; FIG. 2 is a top plan view thereof; FIG. 3 is a front elevational view thereof; FIG. 4 is a left side elevational view thereof; FIG. 5 is a right side elevational view thereof; FIG. 6 is a bottom plan view thereof; FIG. 7 is a rear elevational view thereof; FIG. 8 is a perspective view of the wire tap connector showing my new design in the closed position.

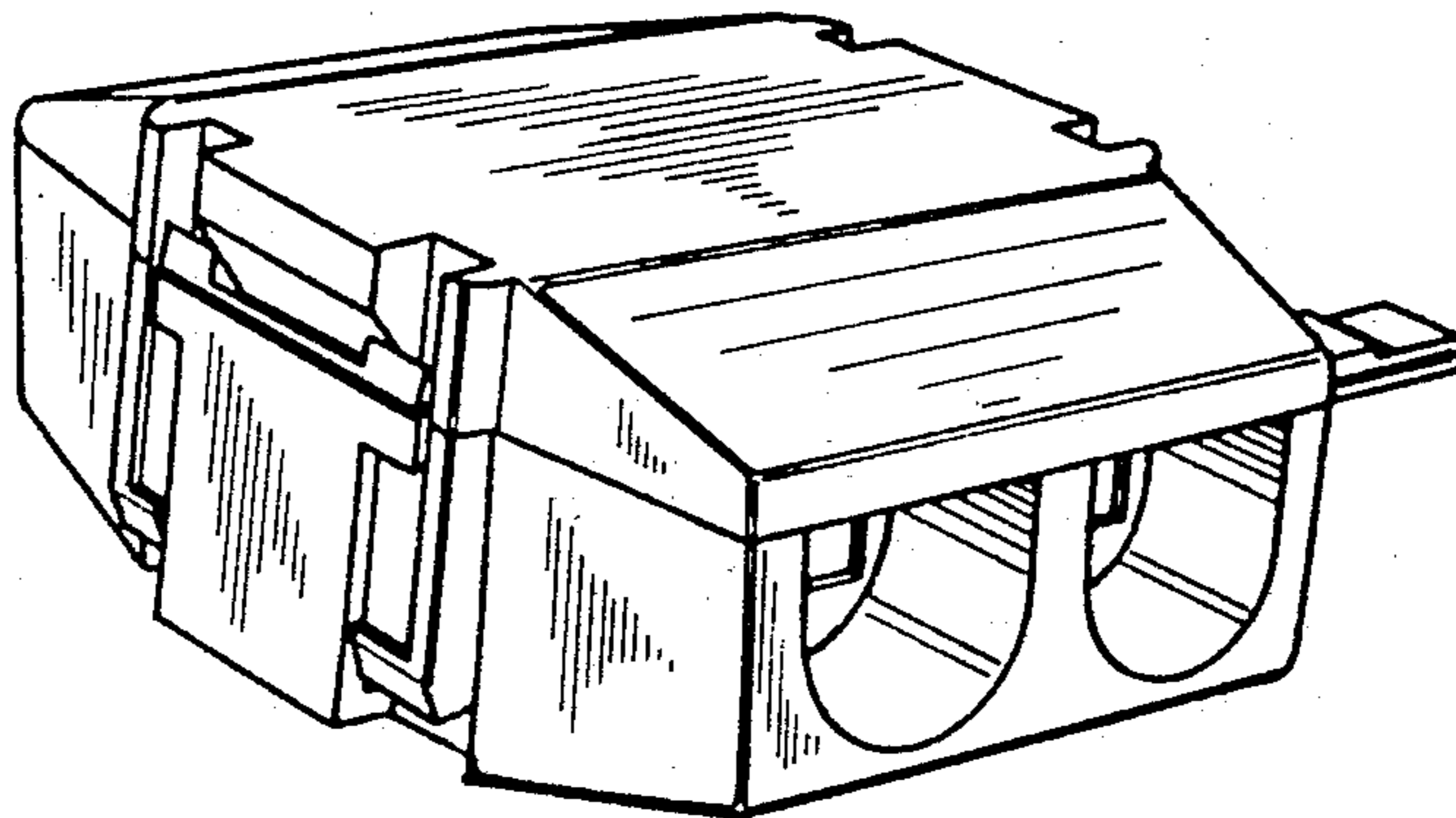

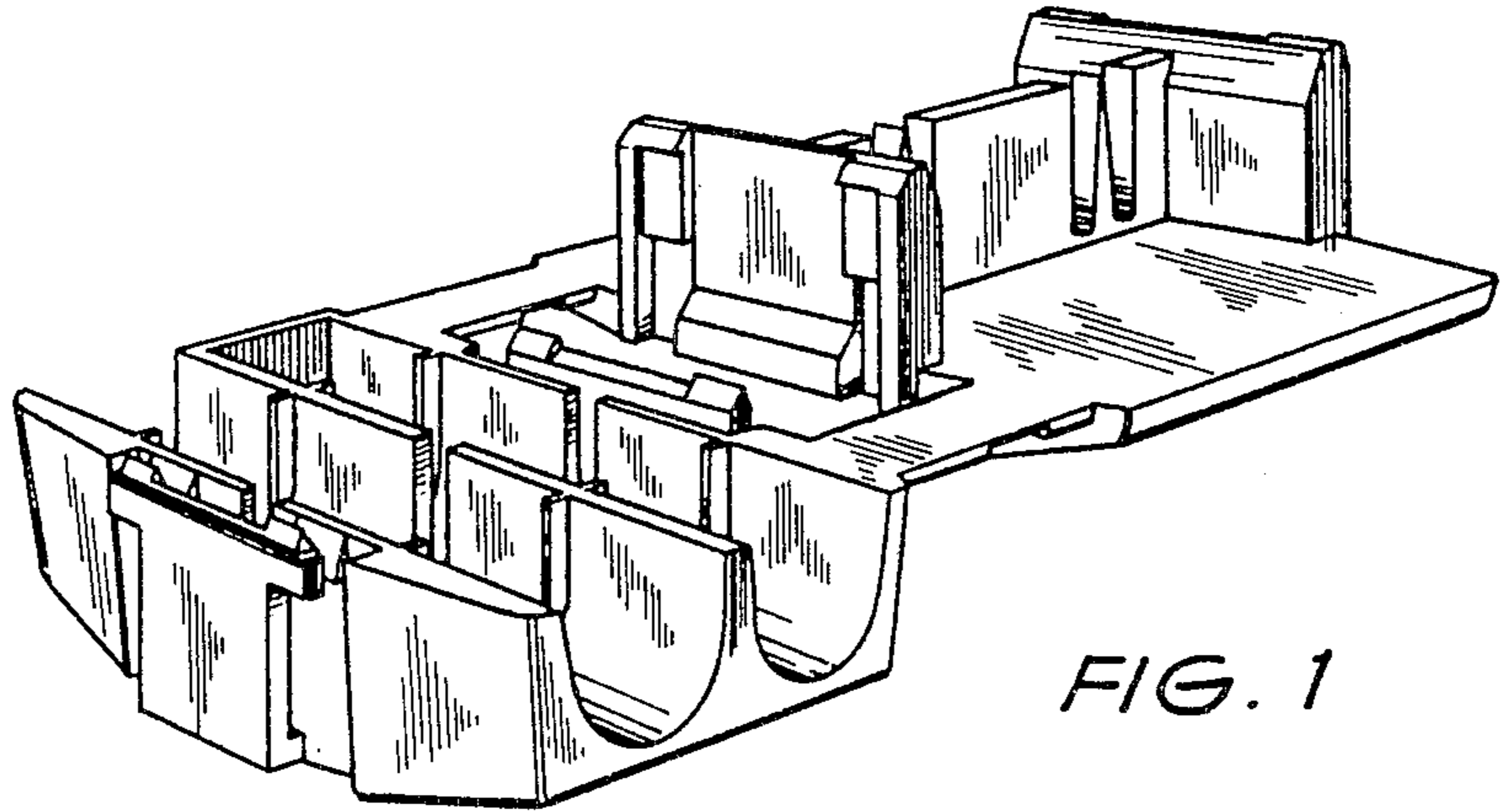

FIG. 1

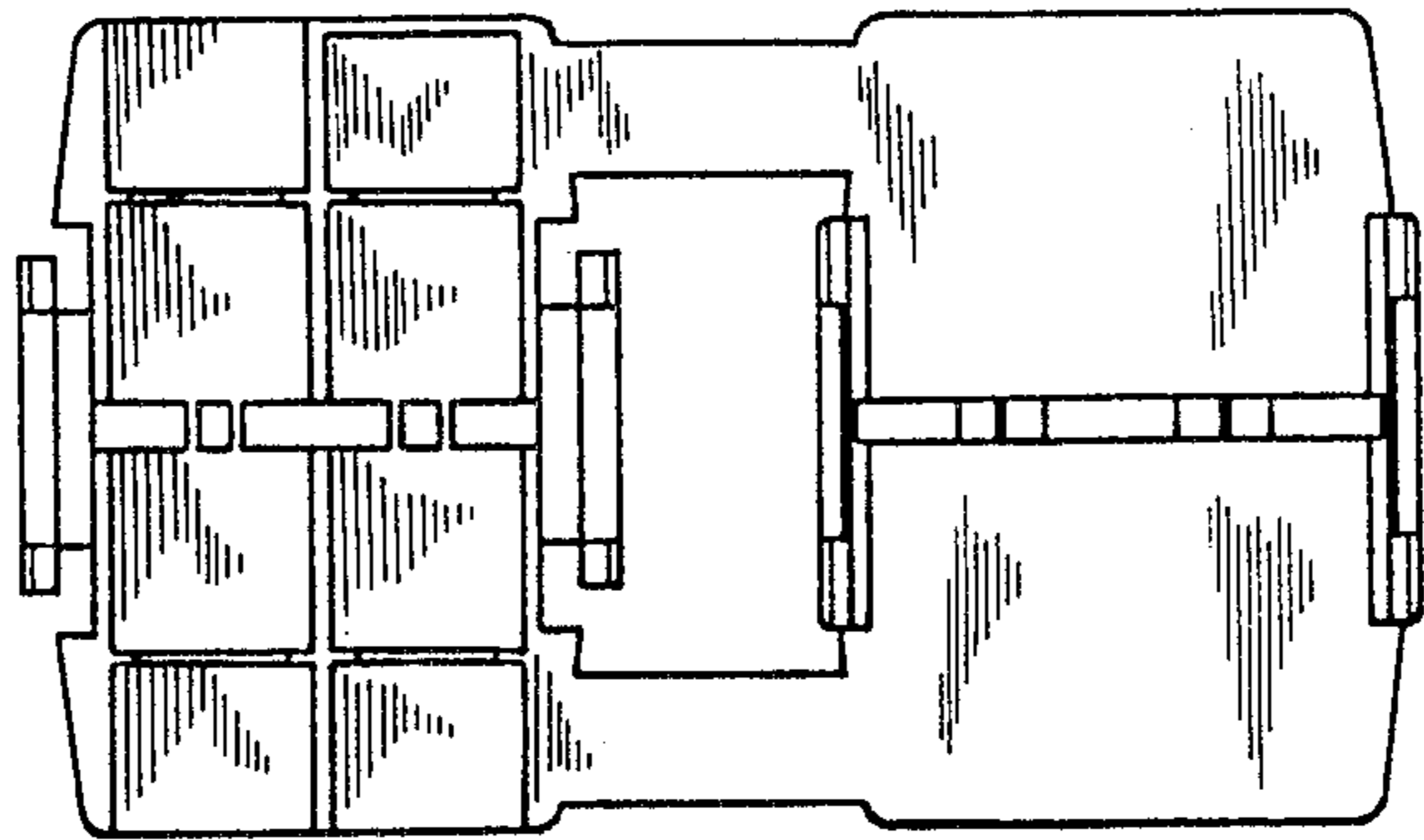

FIG. 2

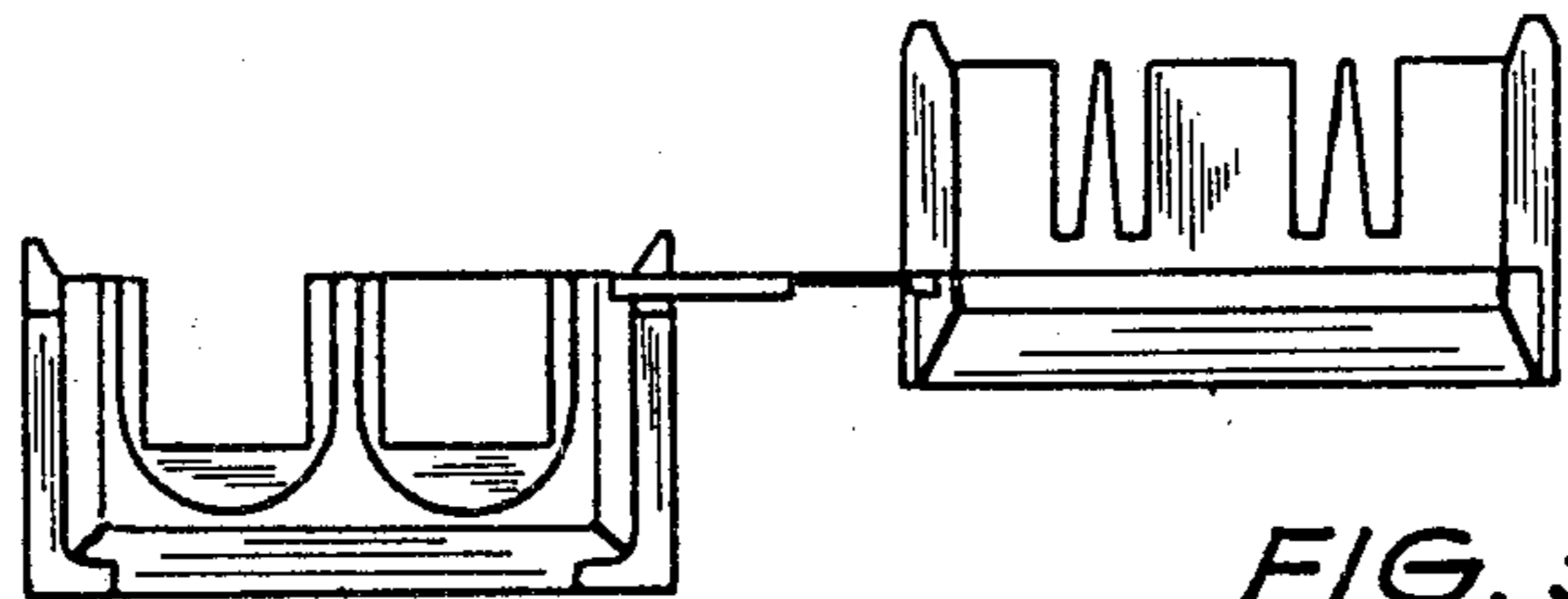

FIG. 3

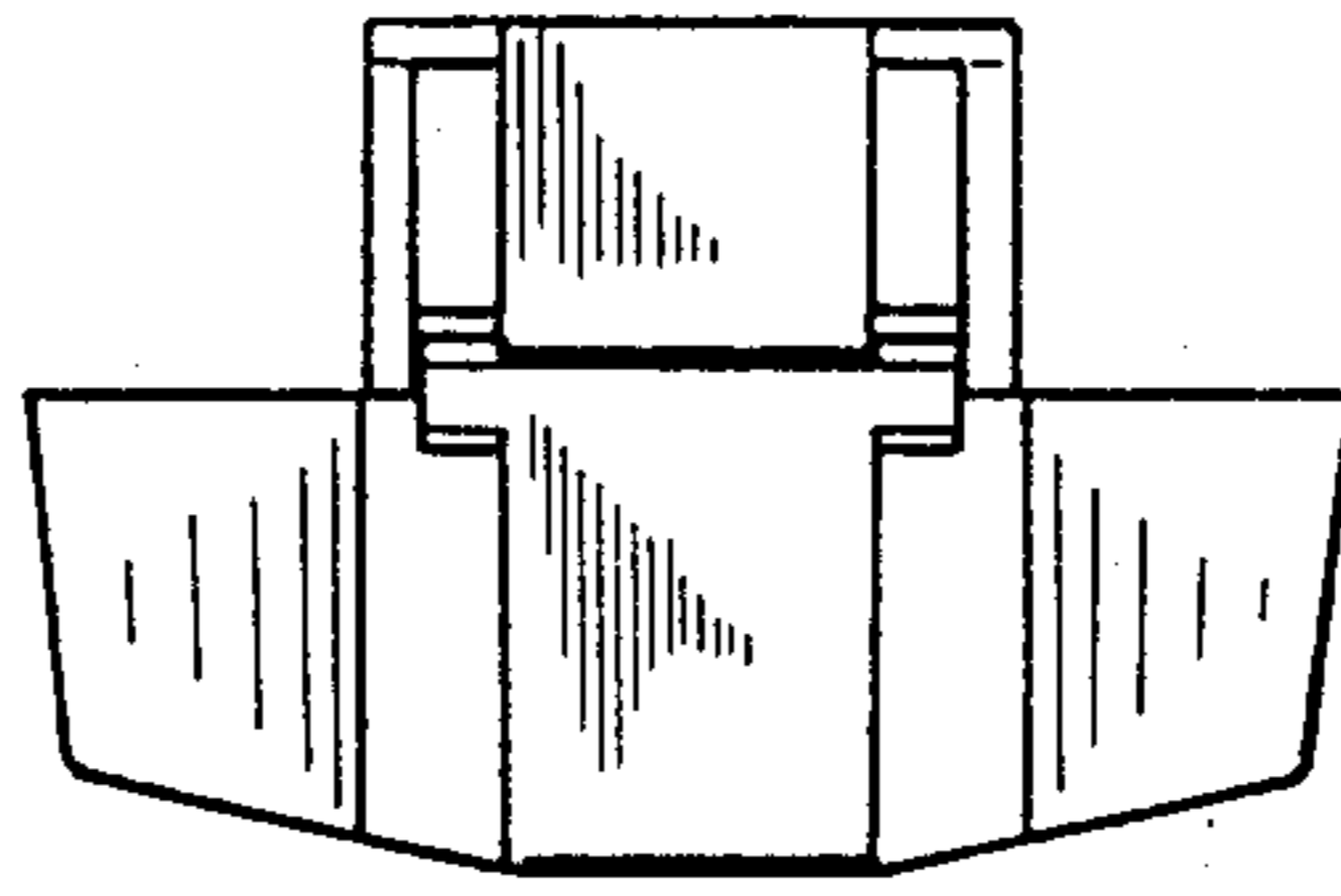

FIG. 4

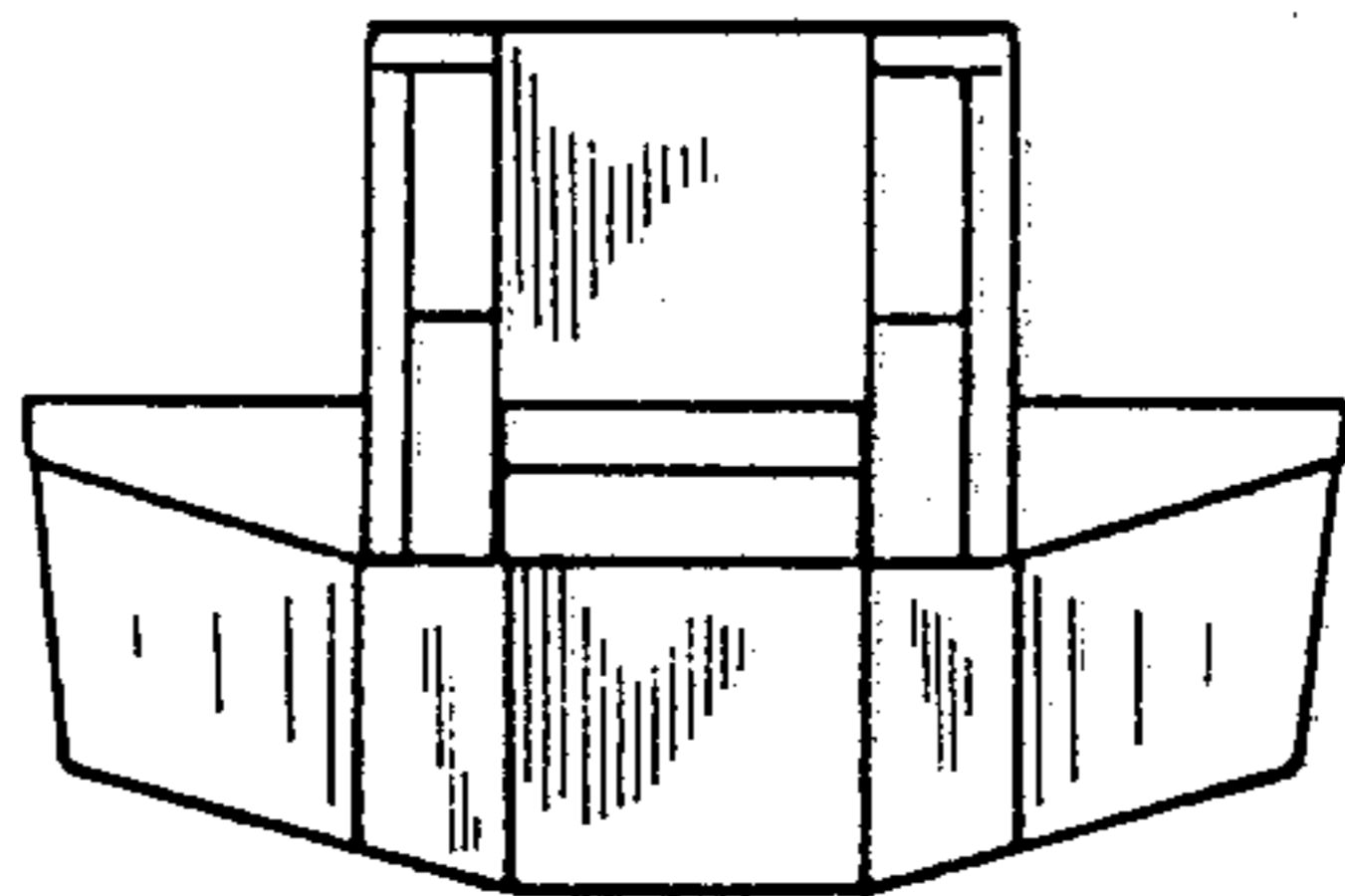

FIG. 5

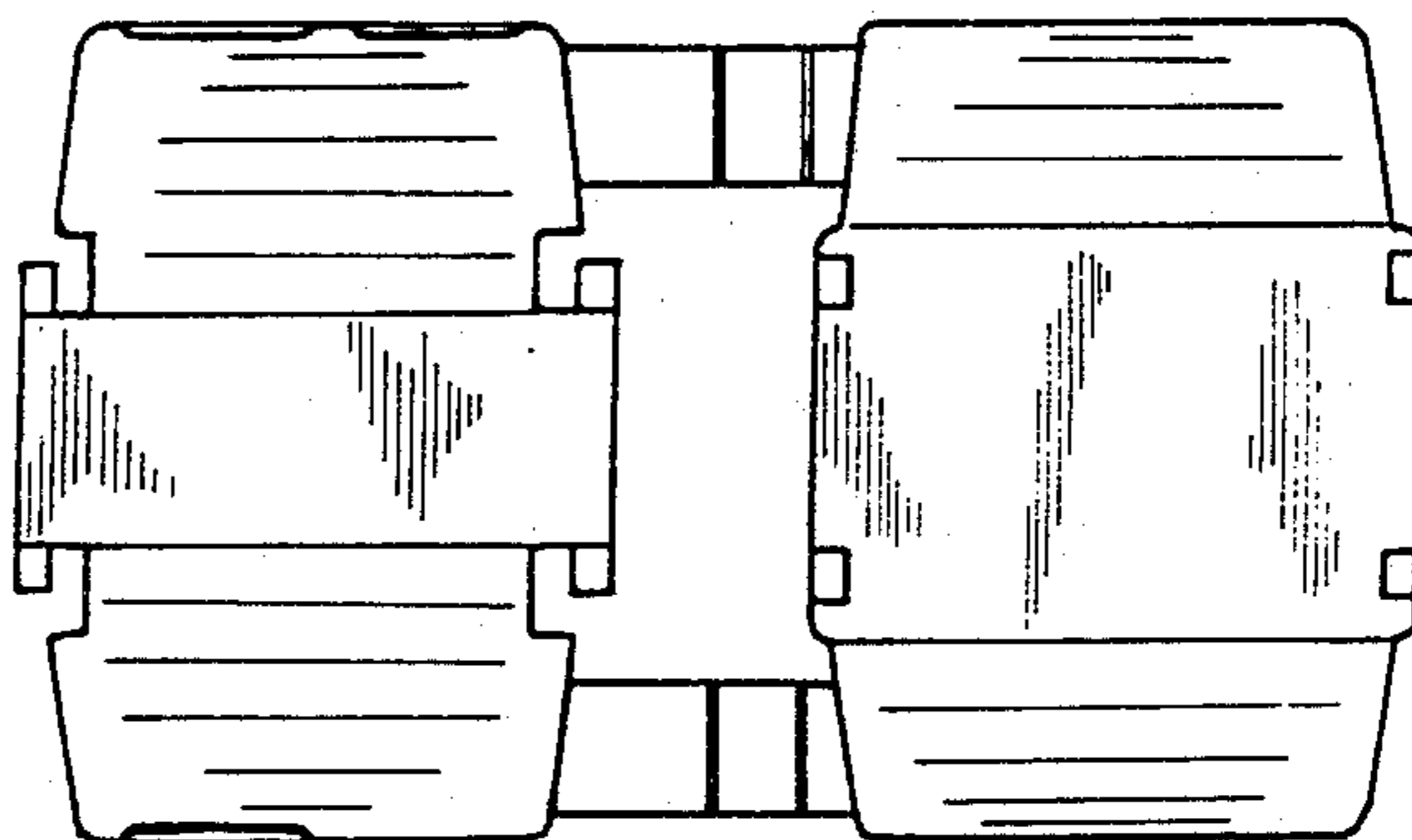

FIG. 6

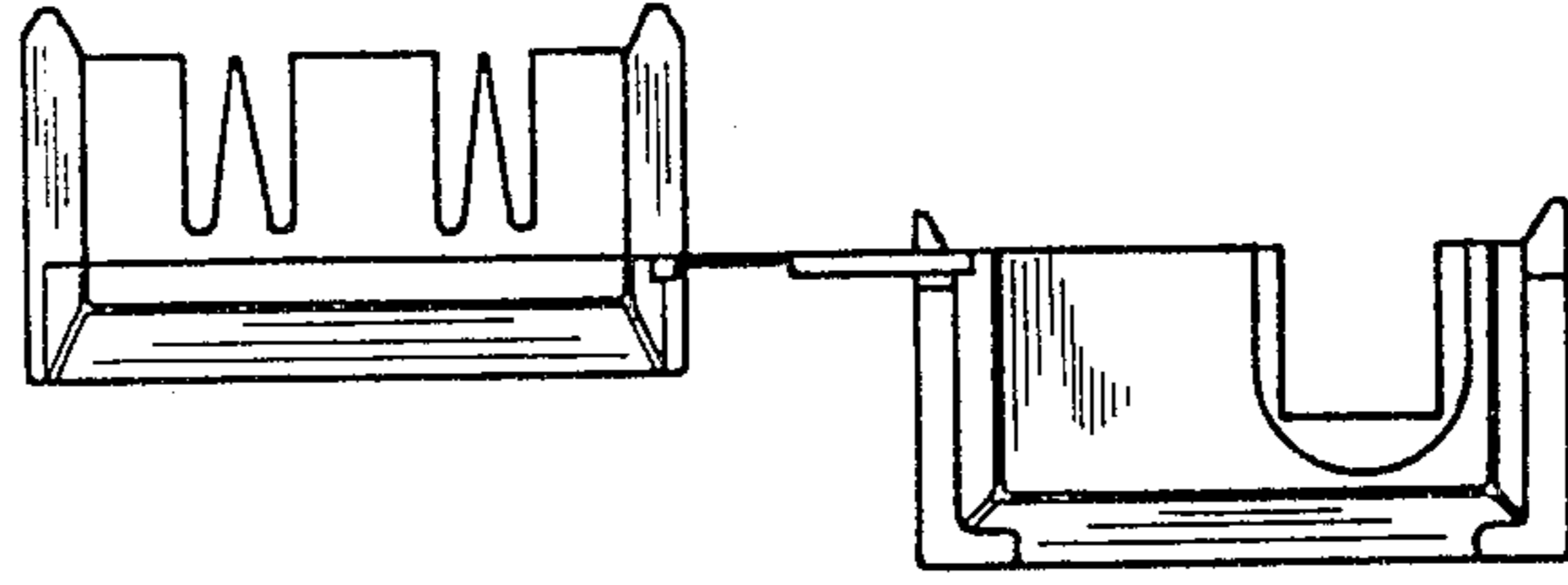
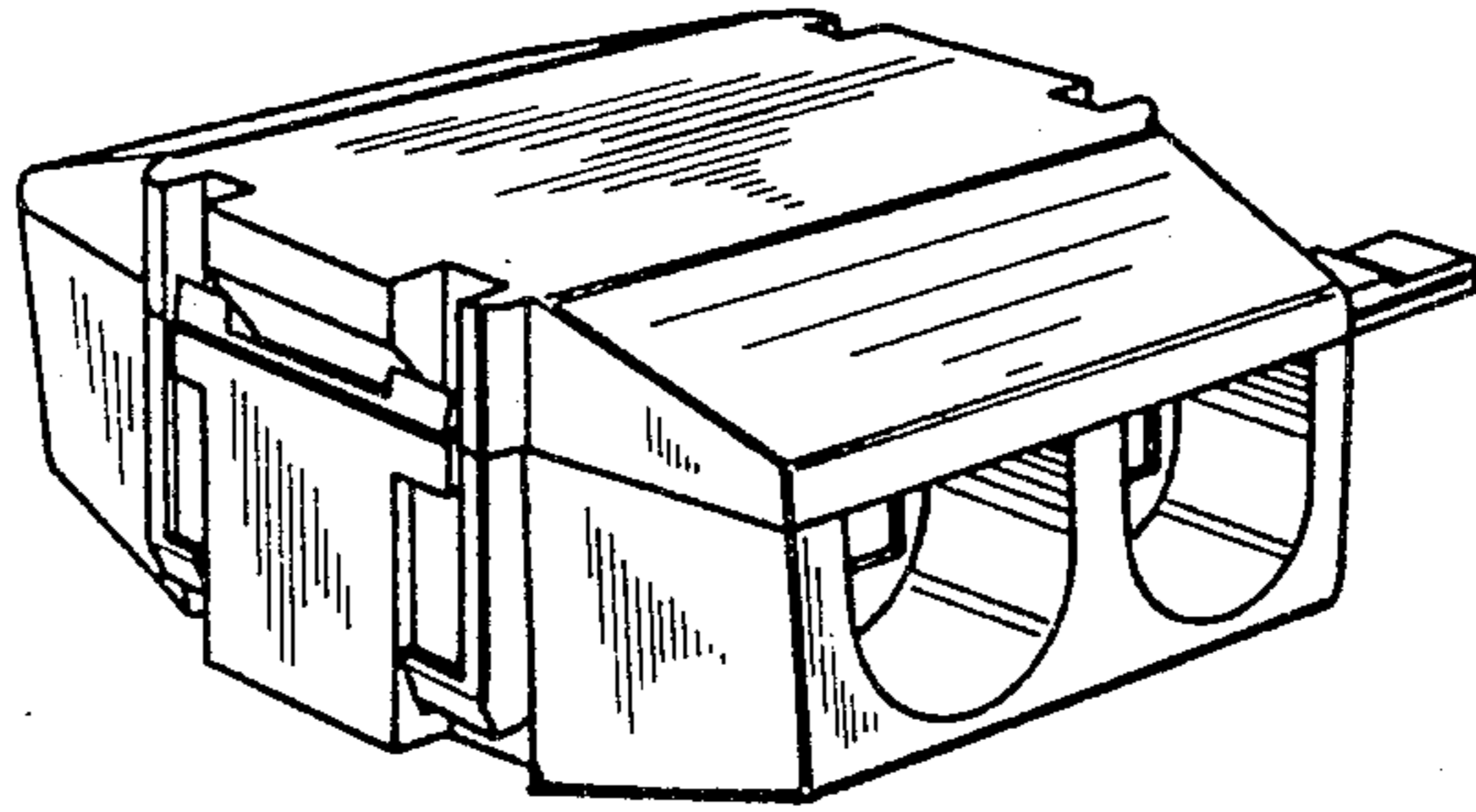

FIG. 7

FIG. 8



UNITED STATES PATENT AND TRADEMARK OFFICE
CERTIFICATE OF CORRECTION

PATENT NO. : Des. 292,087
DATED : September 29, 1987
INVENTOR(S) : Stanley Bryant

It is certified that error appears in the above-identified patent and that said Letters Patent is hereby corrected as shown below:
ON THE TITLE PAGE,

Item [75], change "Sydney Bryant" to --Stanley Bryant--.

Item [73], change "Sydney, Bryant Manufacturing Pty. Ltd." to --Bryant Manufacturing Pty. Ltd.--

**Signed and Sealed this
Twenty-fourth Day of May, 1988**

Attest:

Attesting Officer

DONALD J. QUIGG

Commissioner of Patents and Trademarks