

[54] BICYCLE PEDAL

[76] Inventor: **Hiroyuki Kiyota**, 3-11, Rokucho  
2-Chome, Adachi-Ku, Tokyo, Japan

[\*\*] Term: **14 Years**

[21] Appl. No.: **729,550**

[22] Filed: **May 1, 1985**

[52] U.S. Cl. .... **D12/125**

[58] Field of Search ..... **D12/125; 74/594.4**

[56] **References Cited**

**PUBLICATIONS**

American Bicyclist & Motorcyclist, 11/83, p. 30, HTI-  
-A1 Pedal, upper left side of page.

American Bicyclist & Motorcyclist, 11/83, p. 39, Spe-  
cialized Racing Pedal, bottom left side of page.

*Primary Examiner*—James M. Gandy  
*Attorney, Agent, or Firm*—Lowe, Price, Leblanc, Becker  
& Shur

[57] **CLAIM**

The ornamental design for a bicycle pedal, as shown.

**DESCRIPTION**

FIG. 1 is a perspective view of a bicycle pedal embody-  
ing my new design;

FIG. 2 is a front elevation view;

FIG. 3 is a right side elevation view;

FIG. 4 is a rear elevation view;

FIG. 5 is a left side elevation view;

FIG. 6 is a top plan view;

FIG. 7 is a bottom plan view.

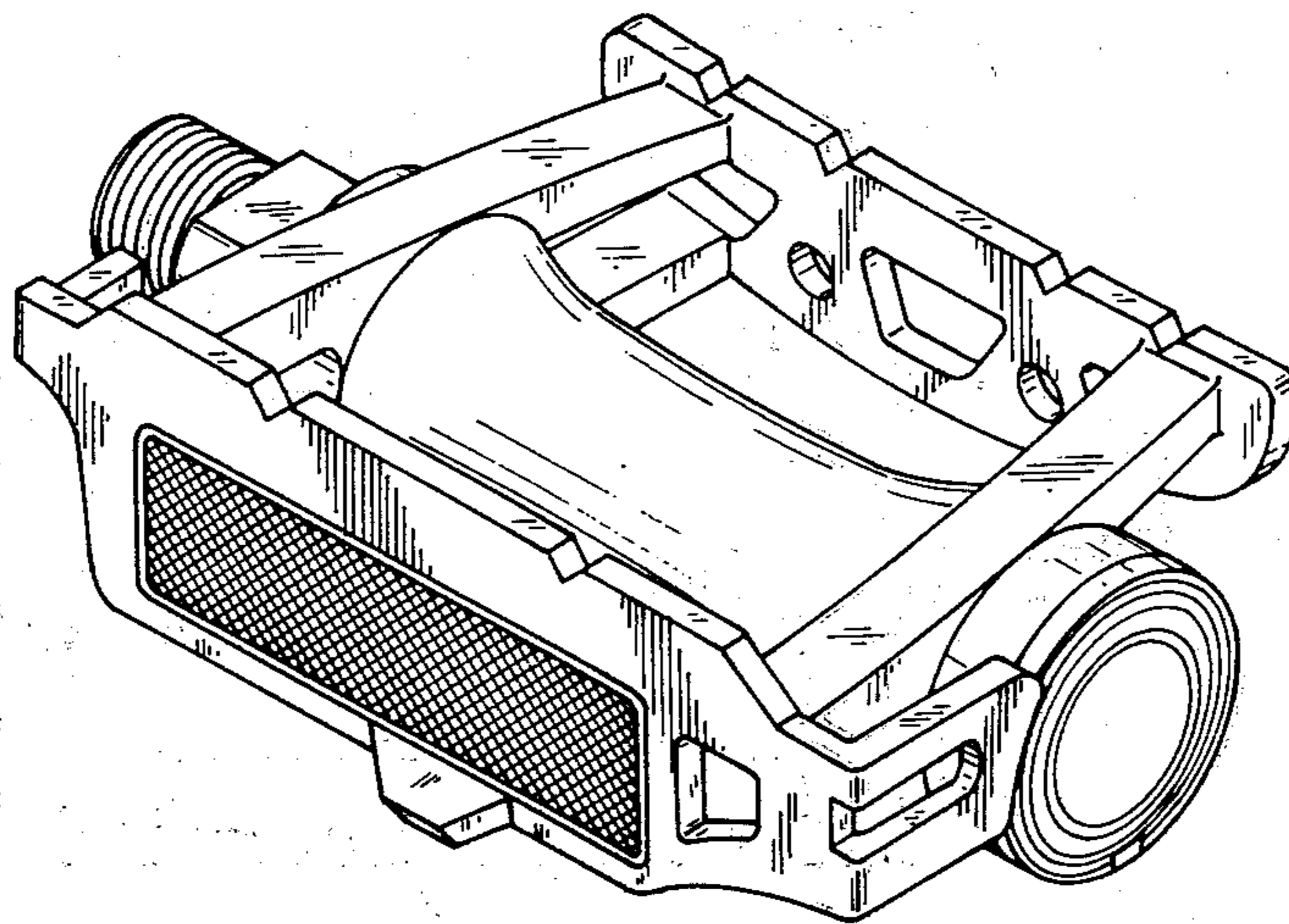

**FIG. 1**

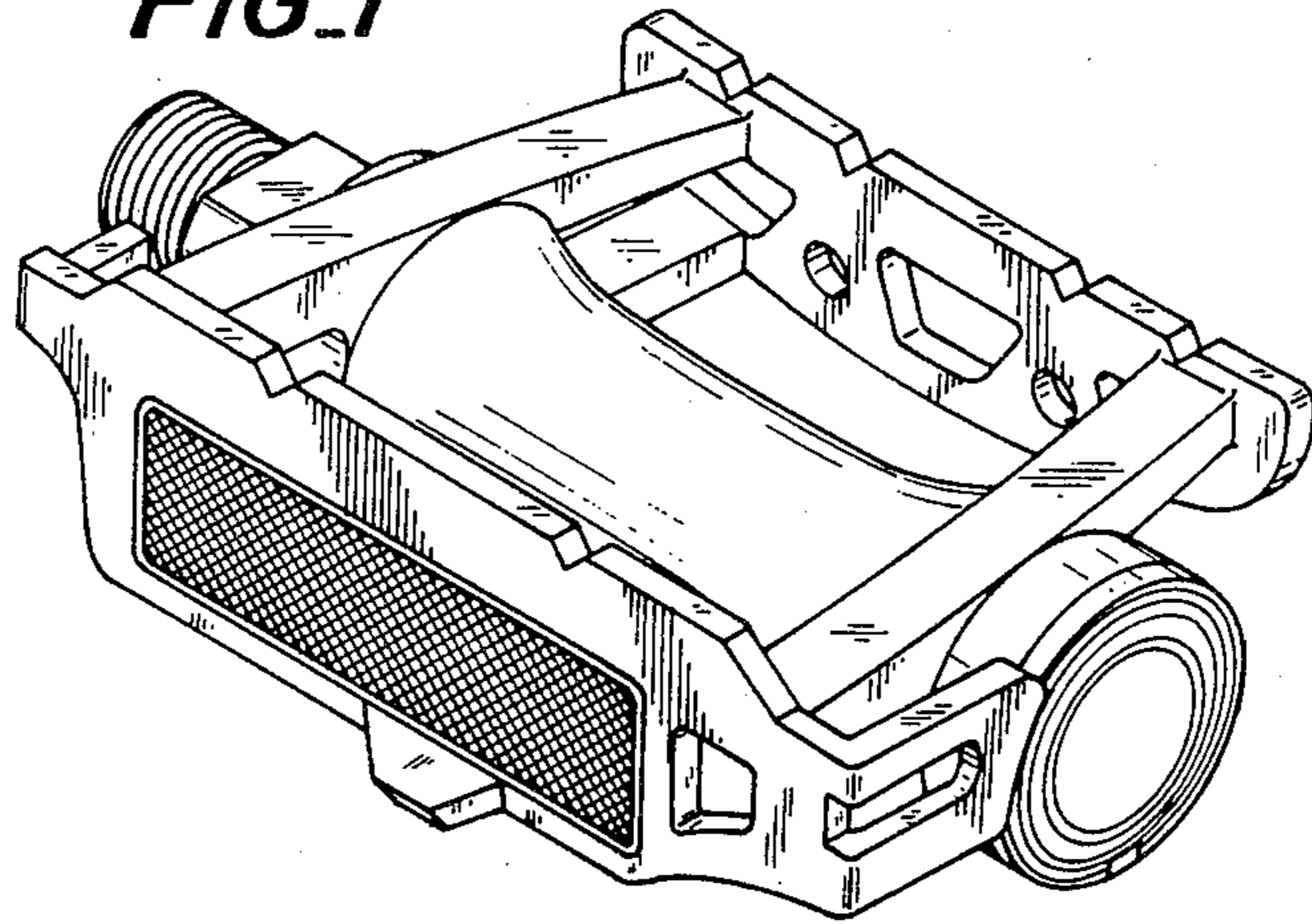

**FIG. 2**

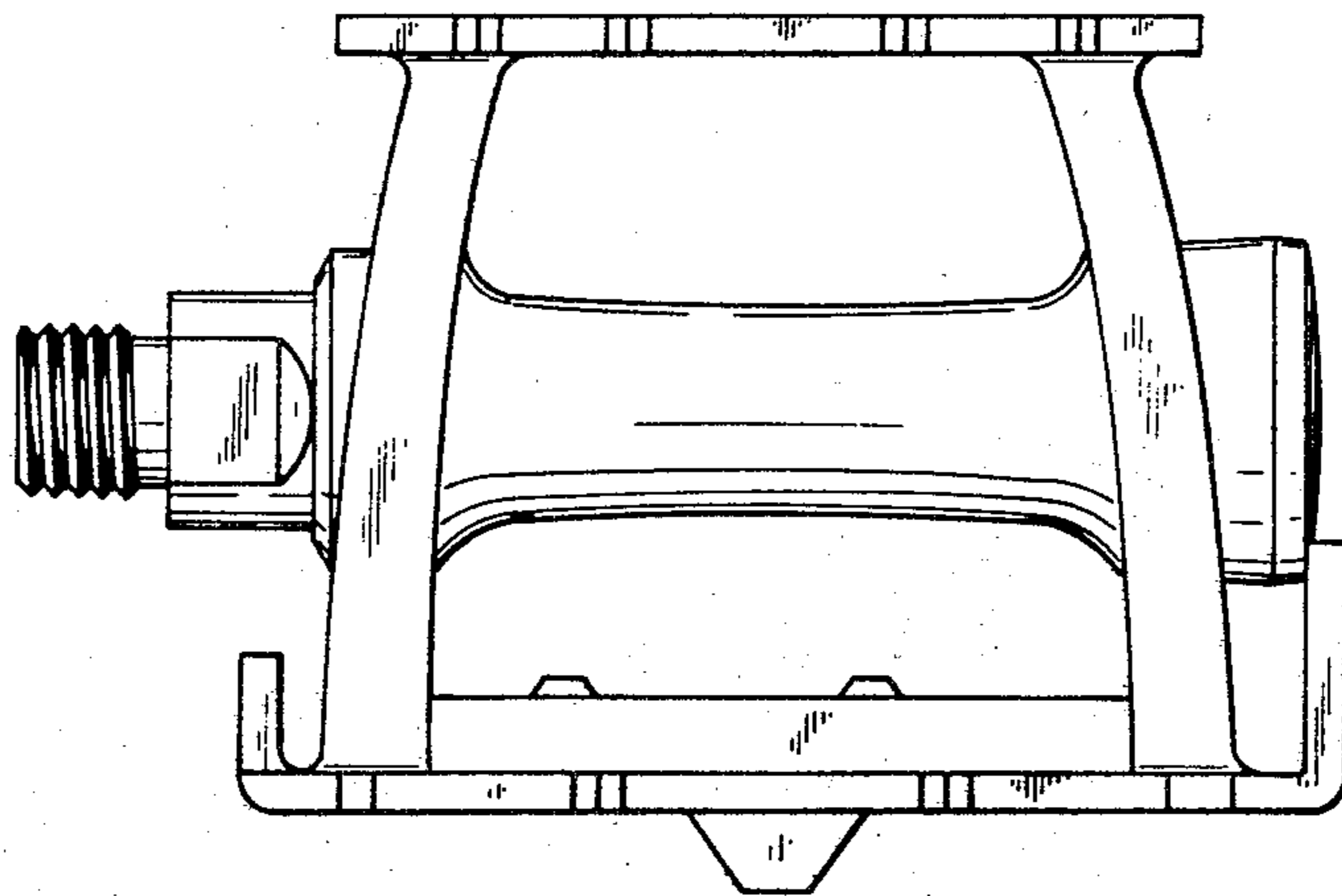

**FIG. 3**

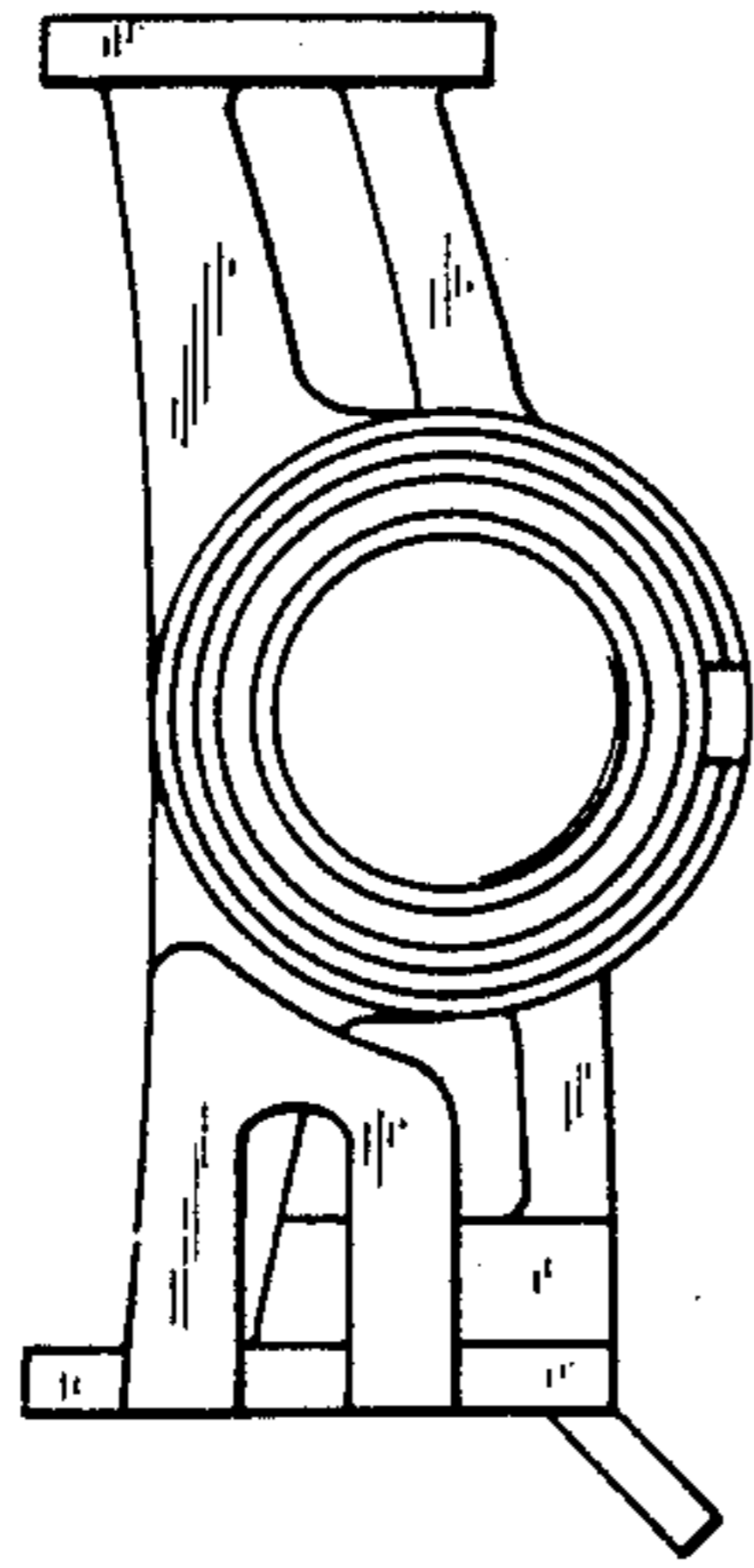

**FIG. 5**

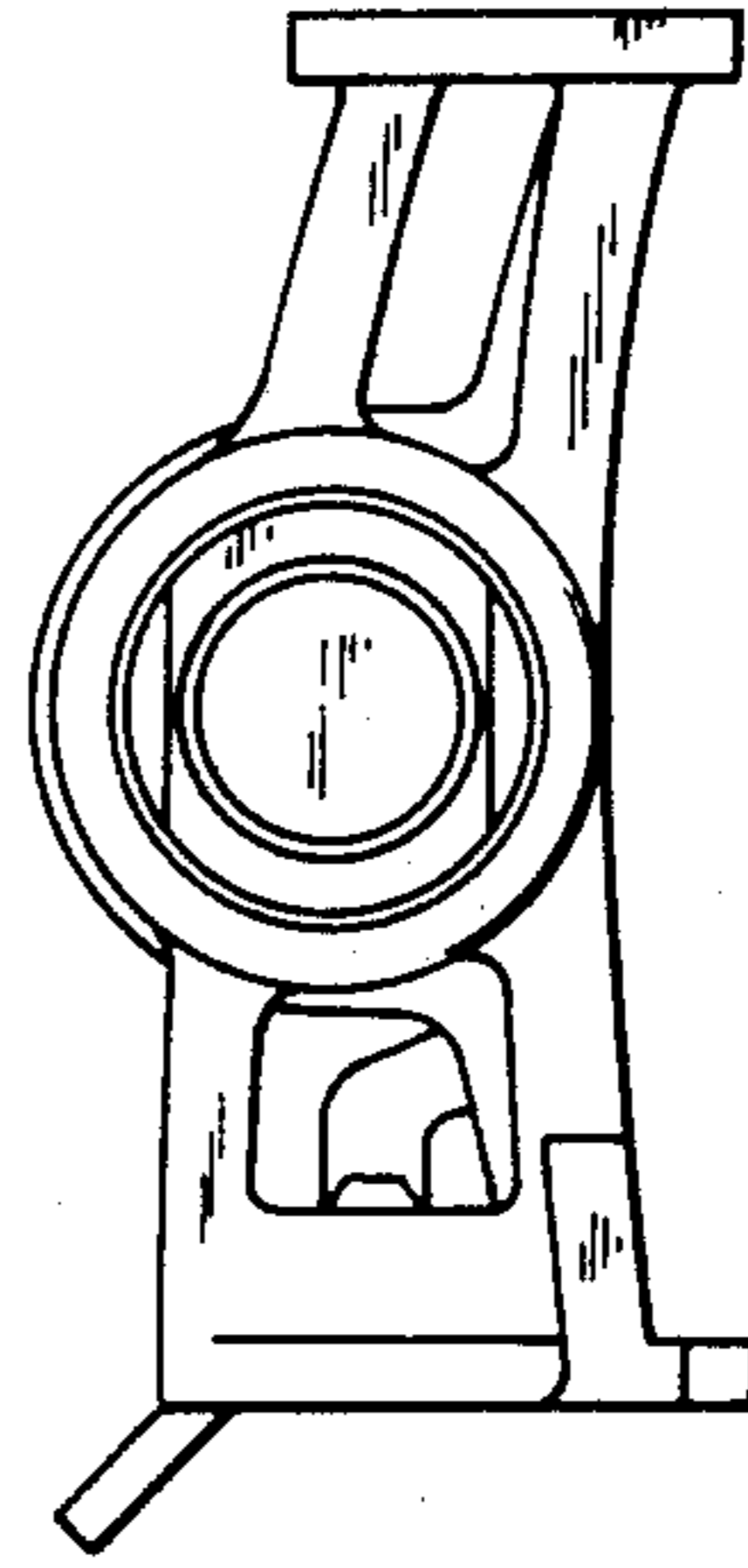

**FIG. 4**

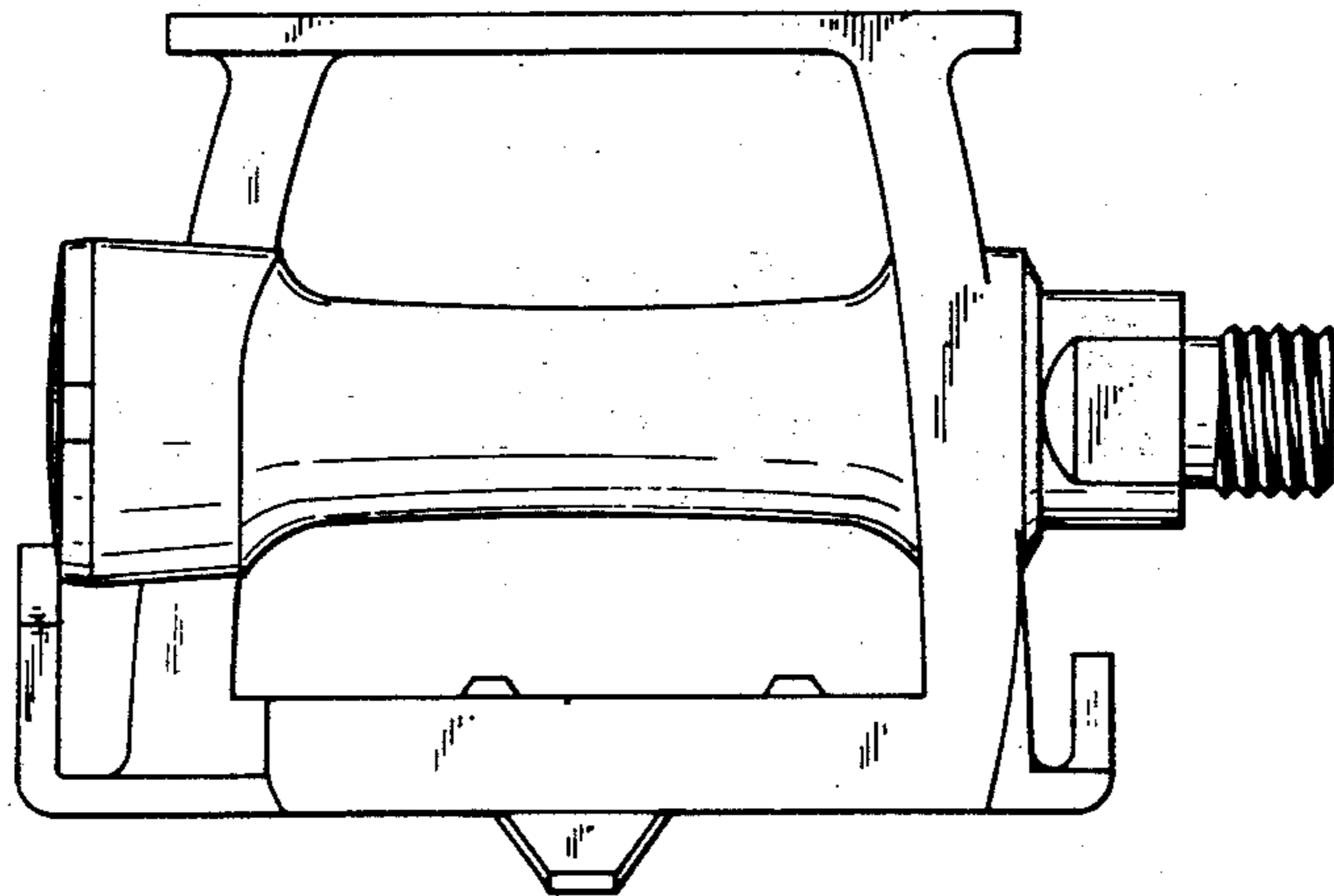

*FIG. 6*

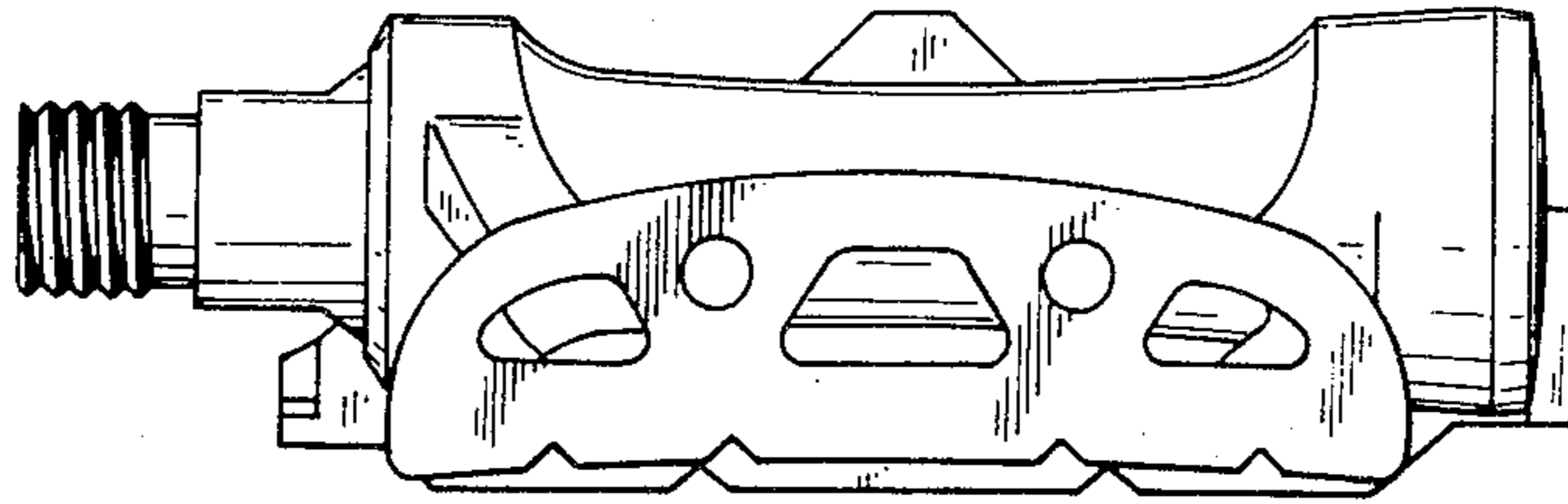

*FIG. 7*

