

[54] **COMBINED AUTOMOBILE DOOR HANDLE AND COVER PLATE**

1,810,510 6/1931 Winne 16/DIG. 2
2,733,474 2/1956 Capitani D8/350

[76] Inventor: **Mark L. Hill**, 3920 E. River Rd.,
Tucson, Ariz. 85718

Primary Examiner—James M. Gandy
Attorney, Agent, or Firm—Cahill, Sutton & Thomas

[**] Term: **14 Years**

[57] **CLAIM**

[21] Appl. No.: **643,846**

The ornamental design for a combined automobile door handle and cover plate, as shown and described.

[22] Filed: **Aug. 23, 1984**

DESCRIPTION

[52] U.S. Cl. **D8/302; D8/353**

[58] Field of Search D12/190; D8/350, 353,
D8/302, 307, 308, 315, 316; 16/1 R, DIG 2,
110 R; 248/345.1; 428/31; 292/DIG. 23, DIG.
67

FIG. 1 is a perspective view of a combined automobile door handle and cover plate showing my new design, it being understood that the broken lines are for illustrative purposes only and form no part of the claimed design.

[56] **References Cited**

U.S. PATENT DOCUMENTS

D. 151,379 10/1948 MacKichan D8/308
D. 157,116 2/1950 Adams et al. 16/DIG. 2
D. 173,422 11/1954 Frees et al. D12/190
D. 197,210 12/1963 Hill D8/302

FIG. 2 is a perspective view showing the rear and lower surfaces thereof;

FIG. 3 is a perspective view showing the front and top surfaces thereof;

FIG. 4 is a left end elevational view thereof;

FIG. 5 is a right end elevational view thereof; and

FIG. 6 is a top view thereof.

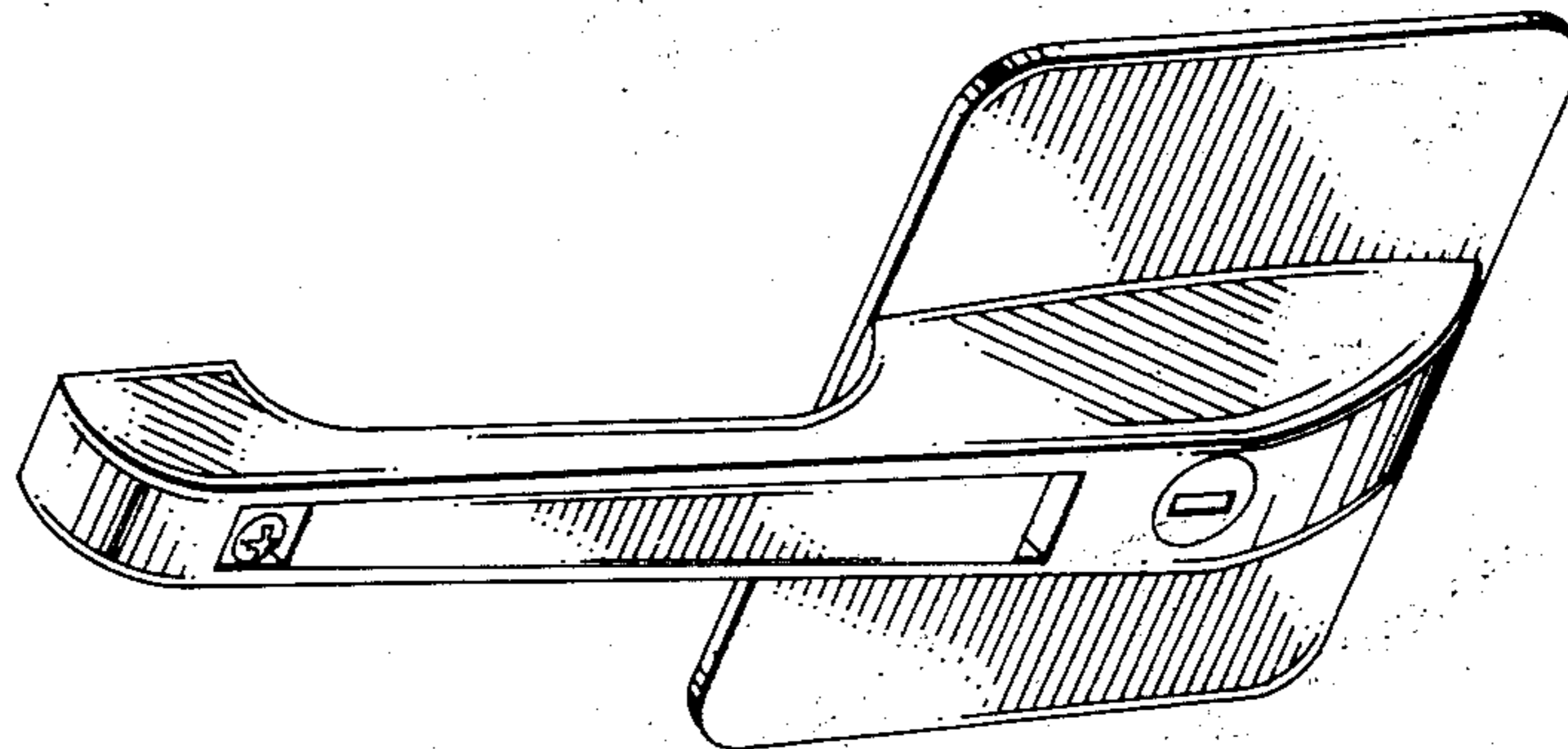

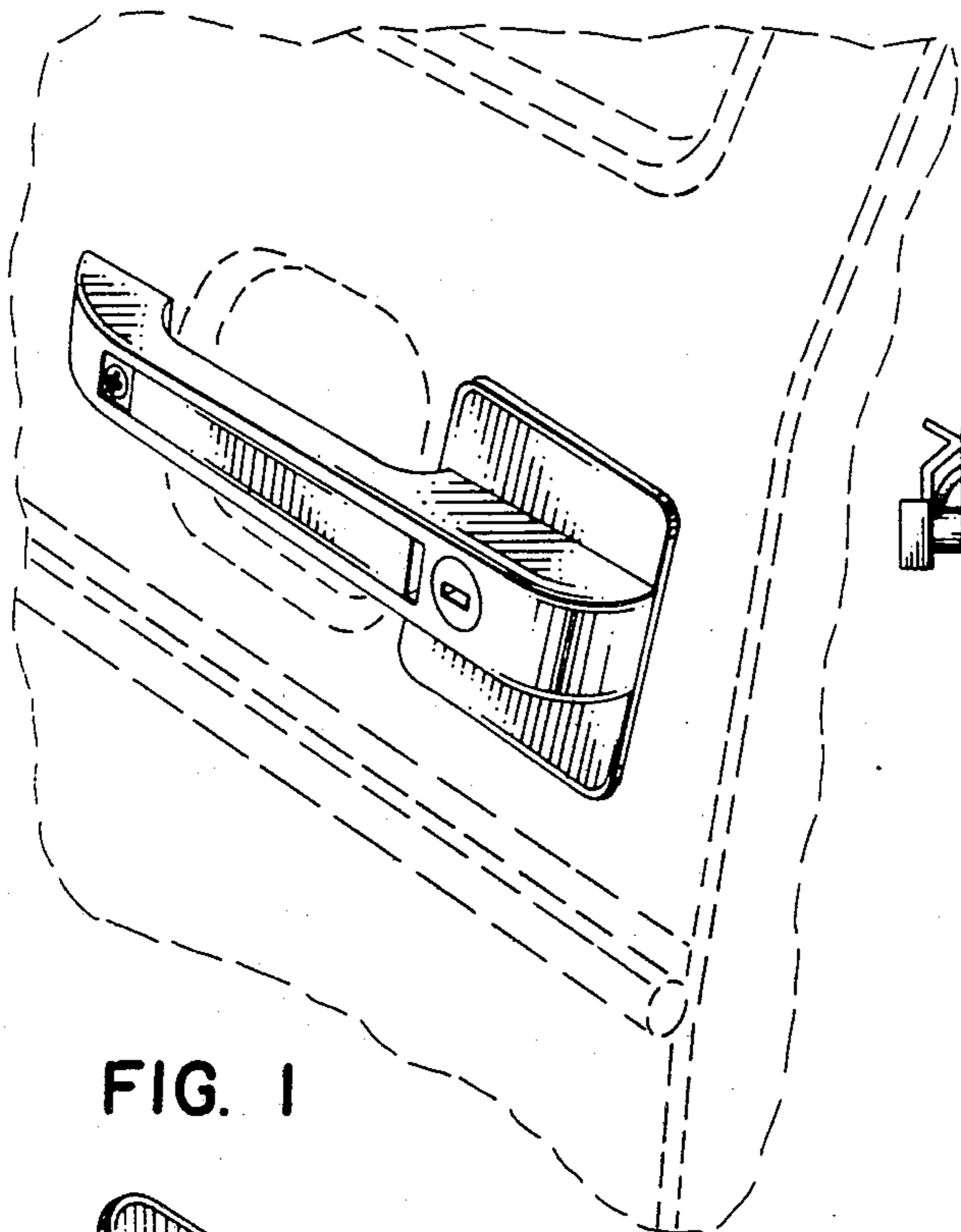

FIG. 1

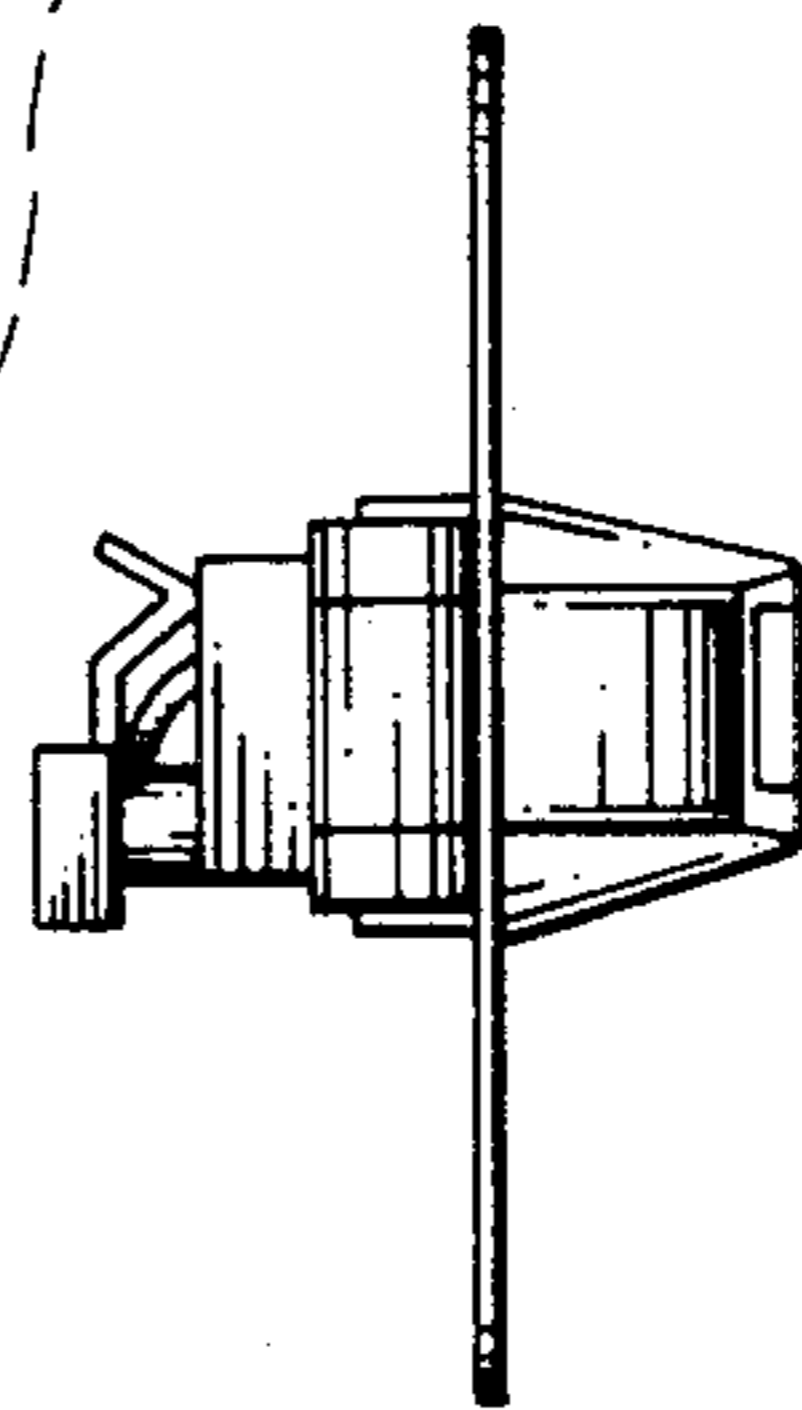

FIG. 4

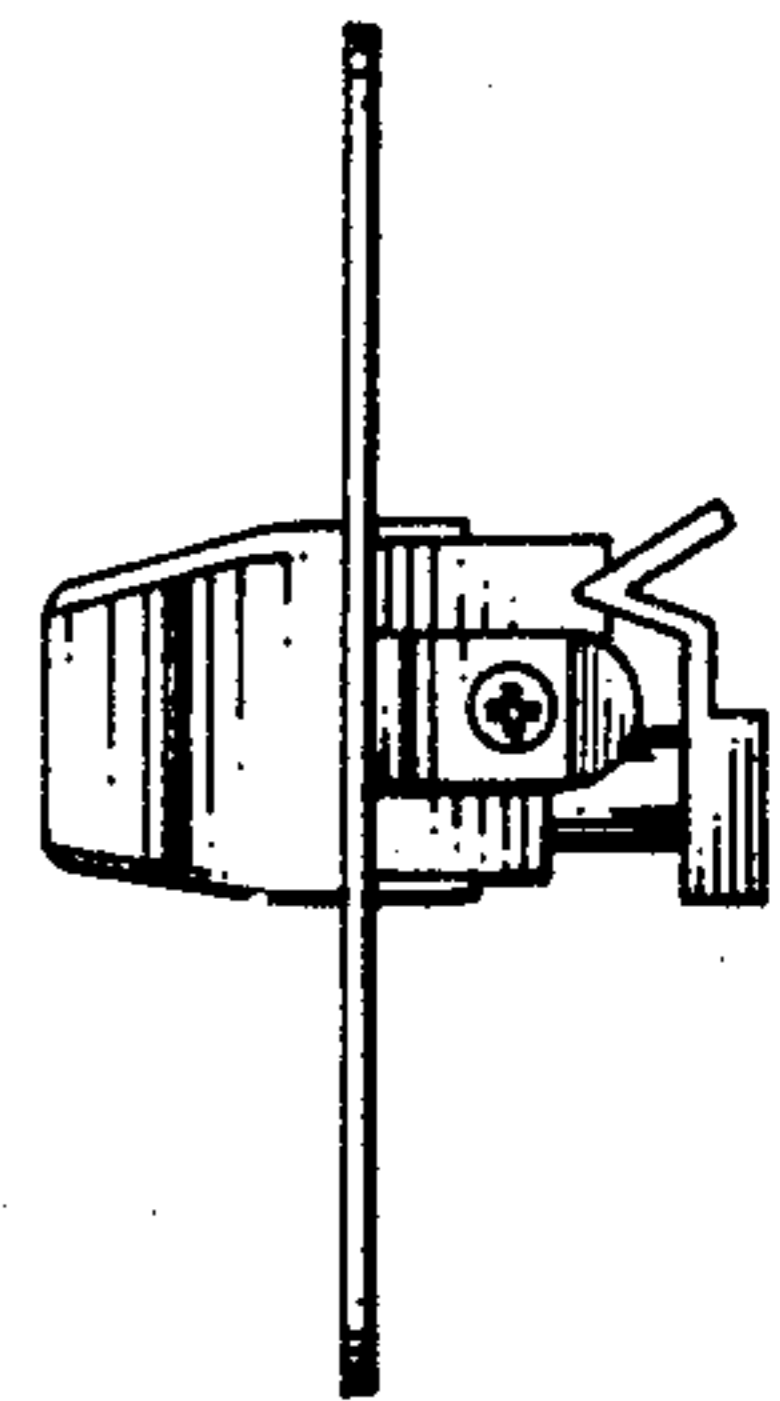

FIG. 5

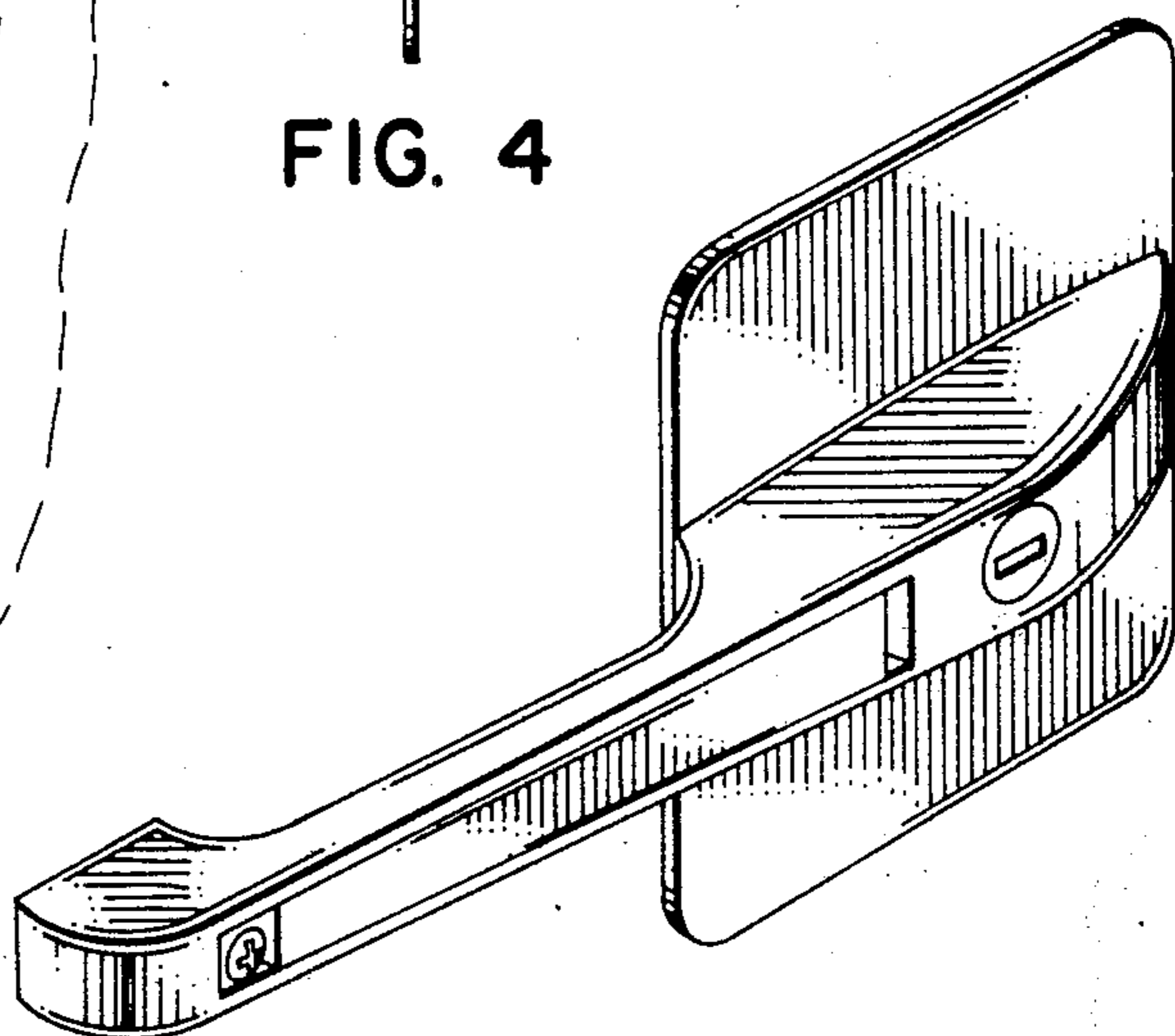

FIG. 3

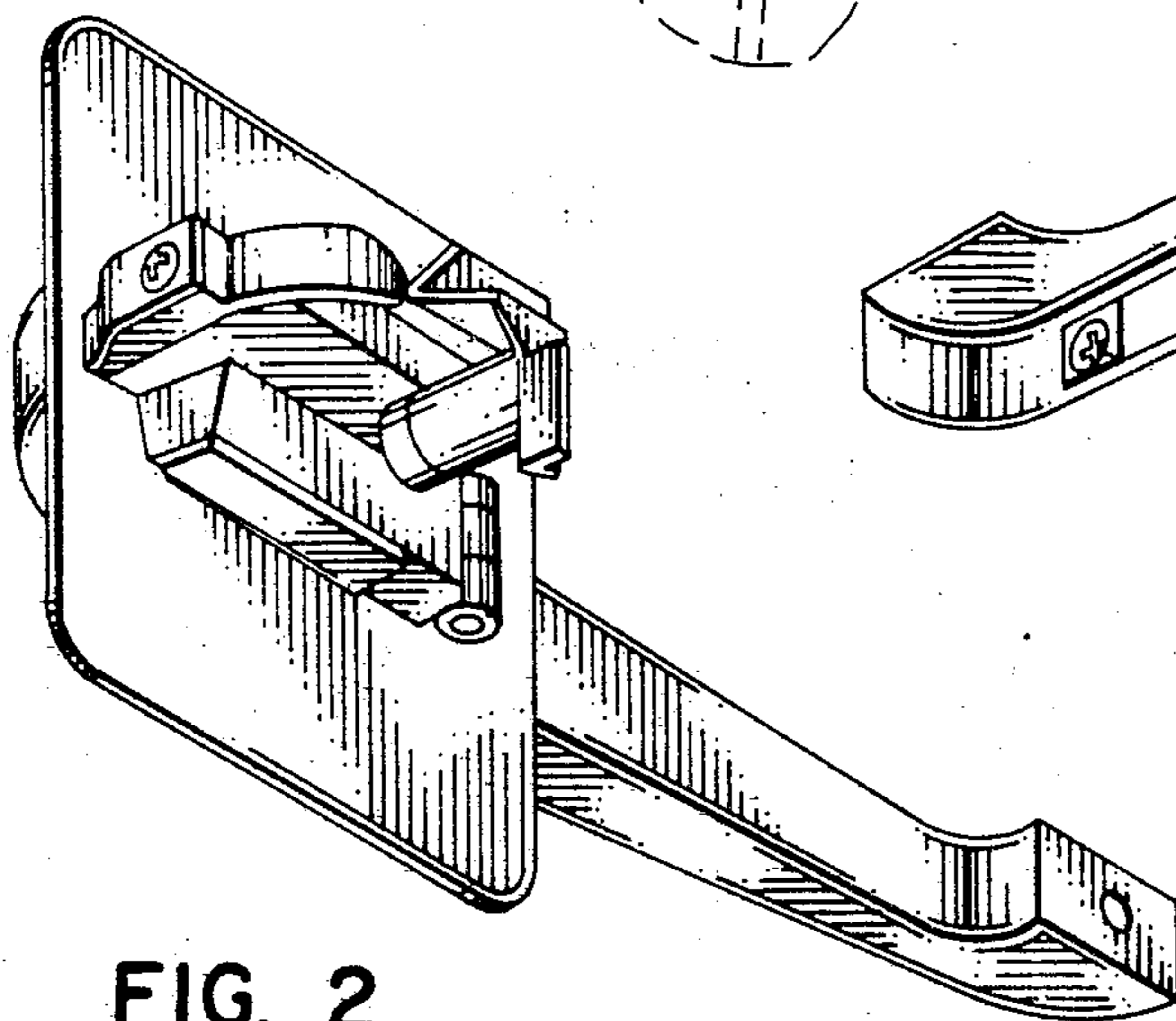

FIG. 2

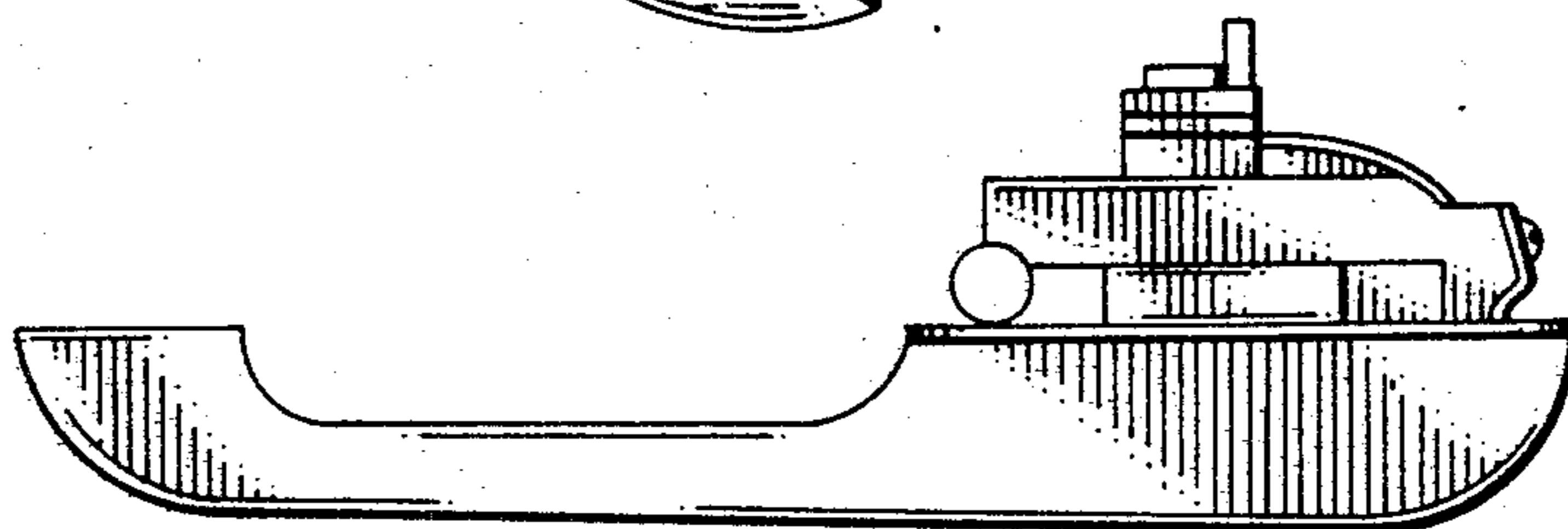

FIG. 6